

Basel Bad Bf - Riehen	
P2B	
Hauptbahn	
120	
4000	
2.6	0.9
2.2	3.0
1.3	4.3

Basel Bad Bf - Grenzach	
GNT+P2B	
Hauptbahn	
130 > 160 <	
4000	
2.5	2.4
271.2	276.6

Basel Bad Bf - Riehen	
P2B	
Hauptbahn	
120	
4000	
2.6	0.9
2.2	3.0
1.3	4.3

Basel Bad Bf - Grenzach	
GNT+P2B	
Hauptbahn	
130 > 160 <	
4000	
2.5	2.4
271.2	276.6

Basel Bad Bf - Riehen	
P2B	
Hauptbahn	
120	
4000	
2.6	0.9
2.2	3.0
1.3	4.3

Basel Bad Bf - Grenzach	
GNT+P2B	
Hauptbahn	
130 > 160 <	
4000	
2.5	2.4
271.2	276.6

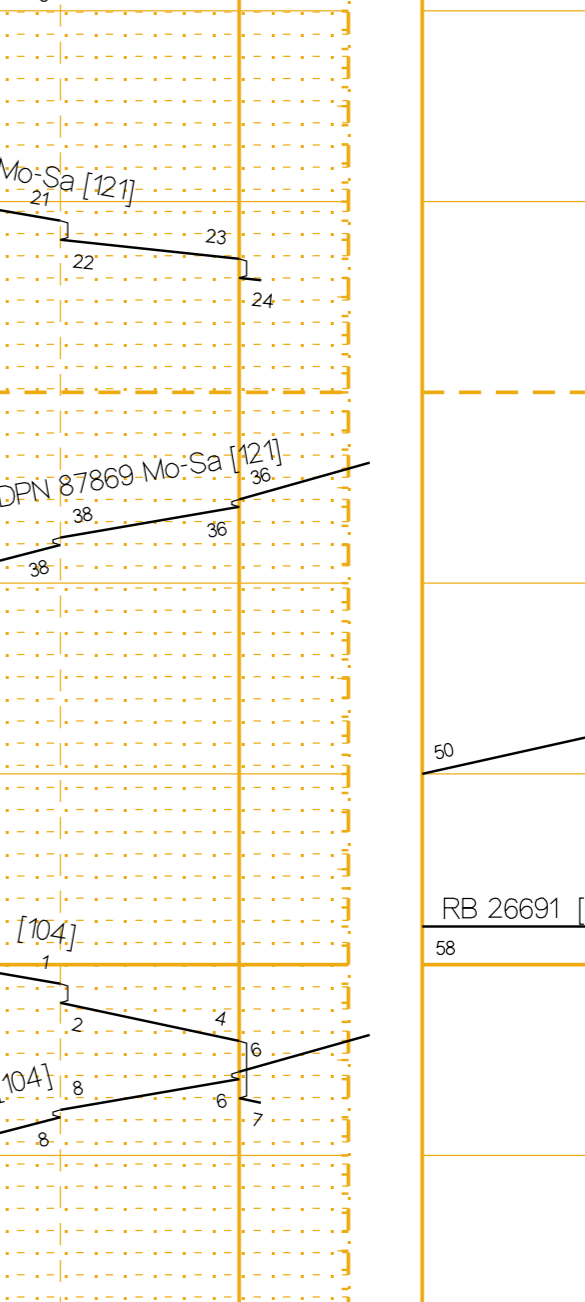
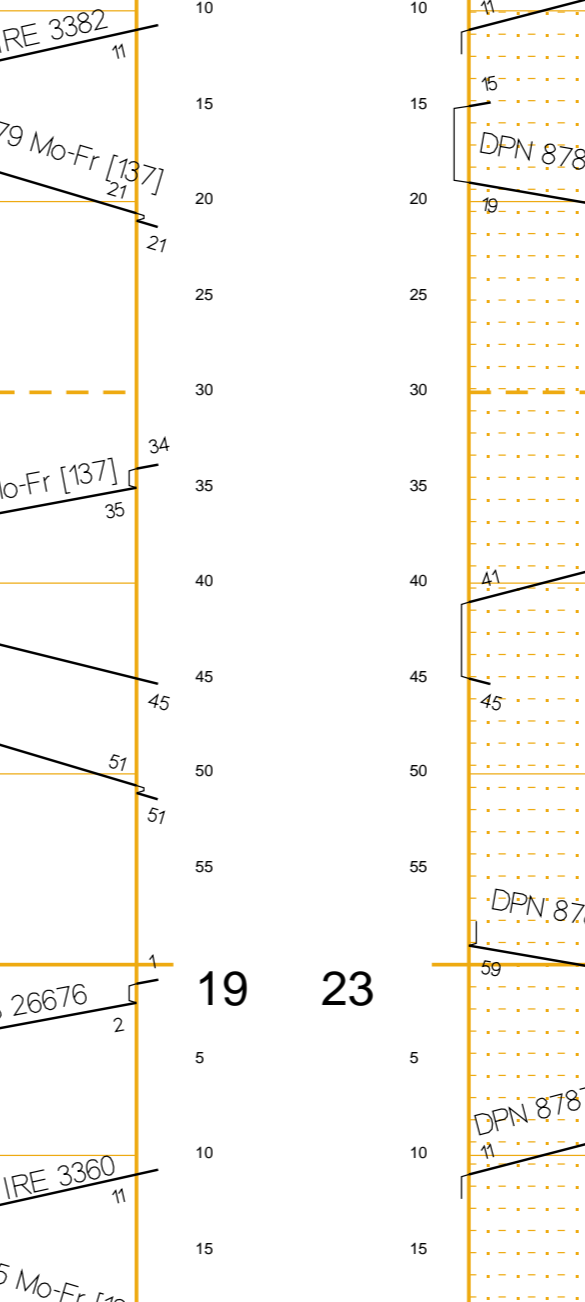
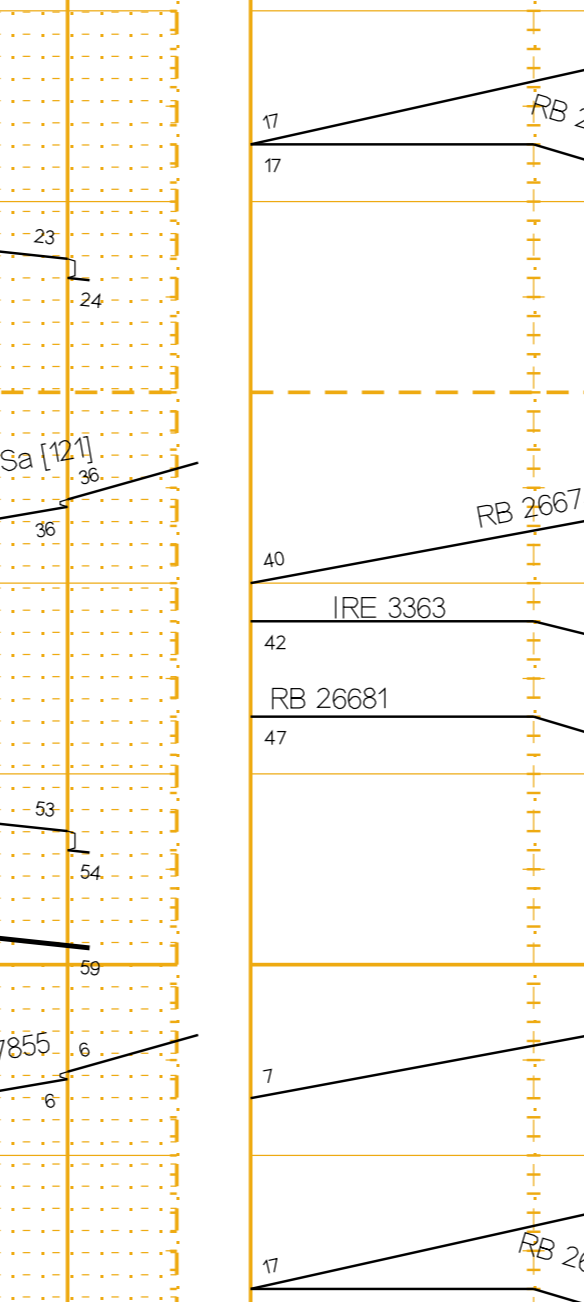
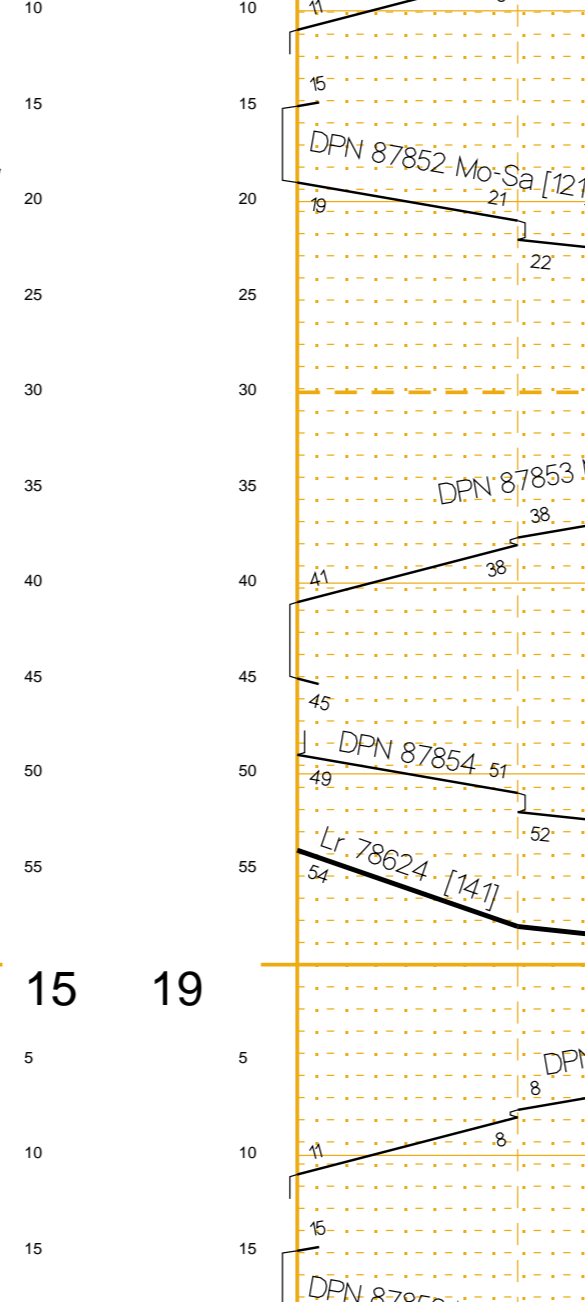
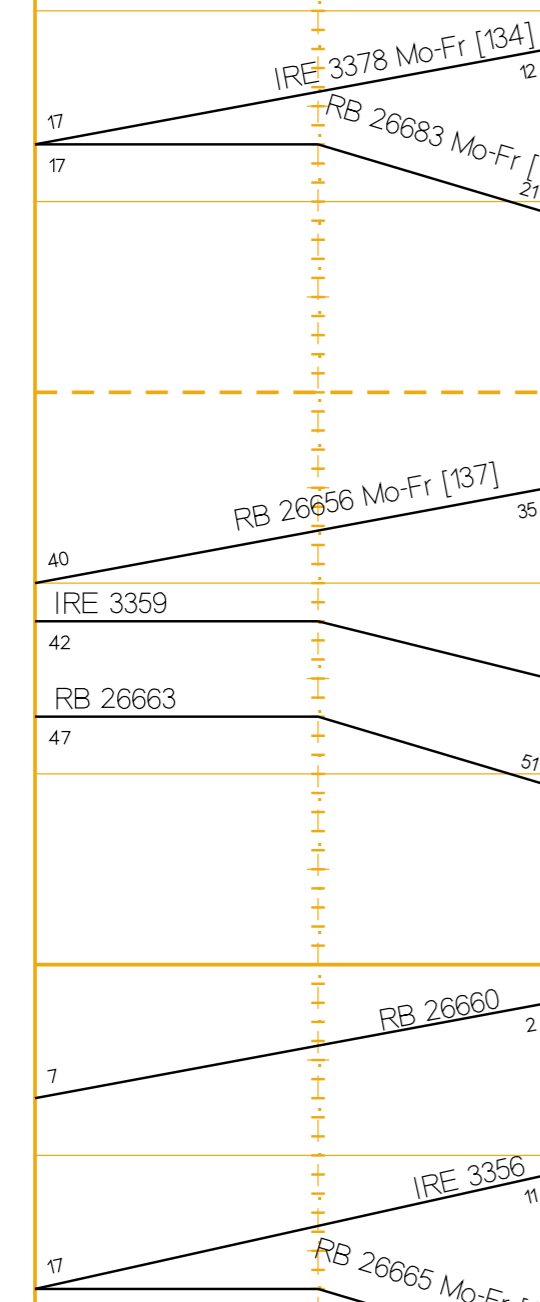
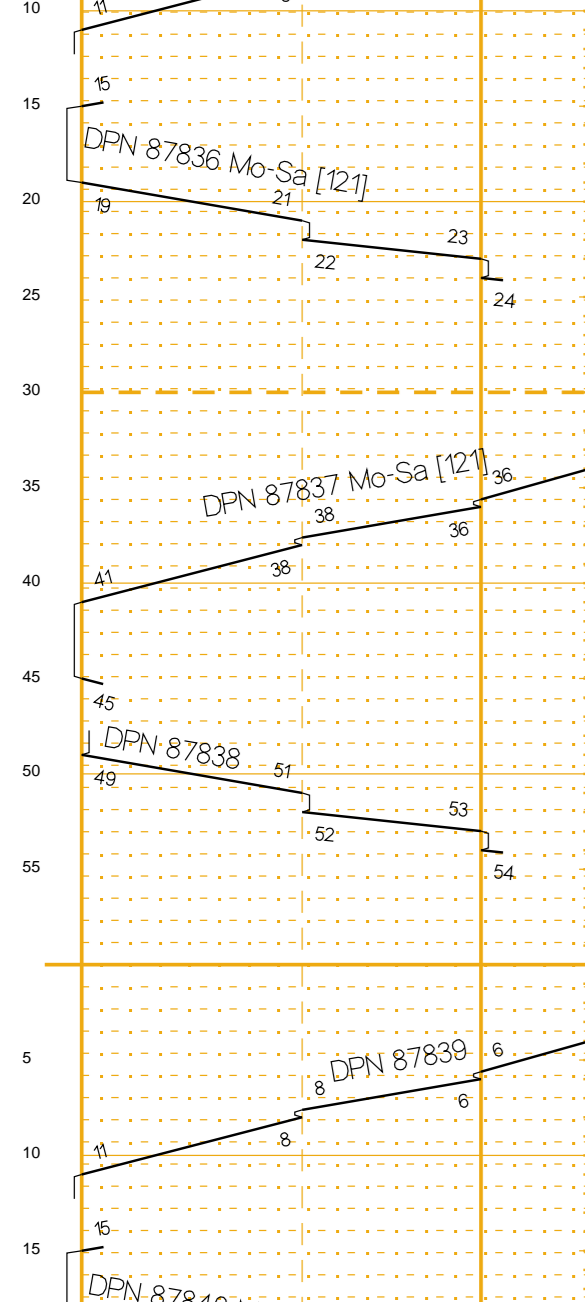
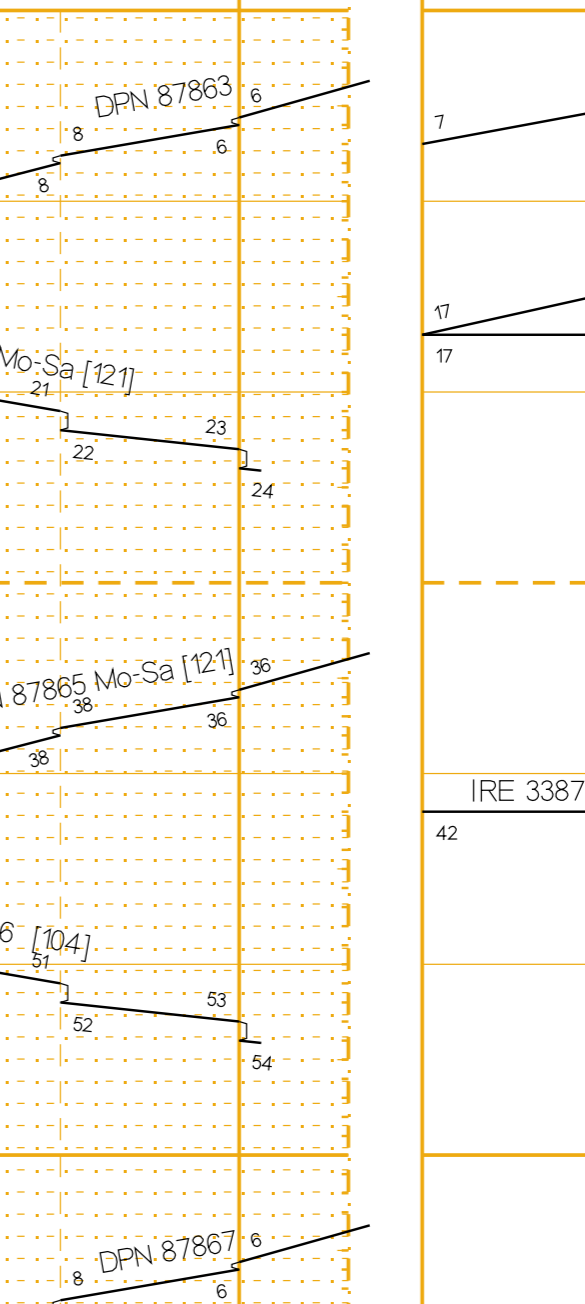
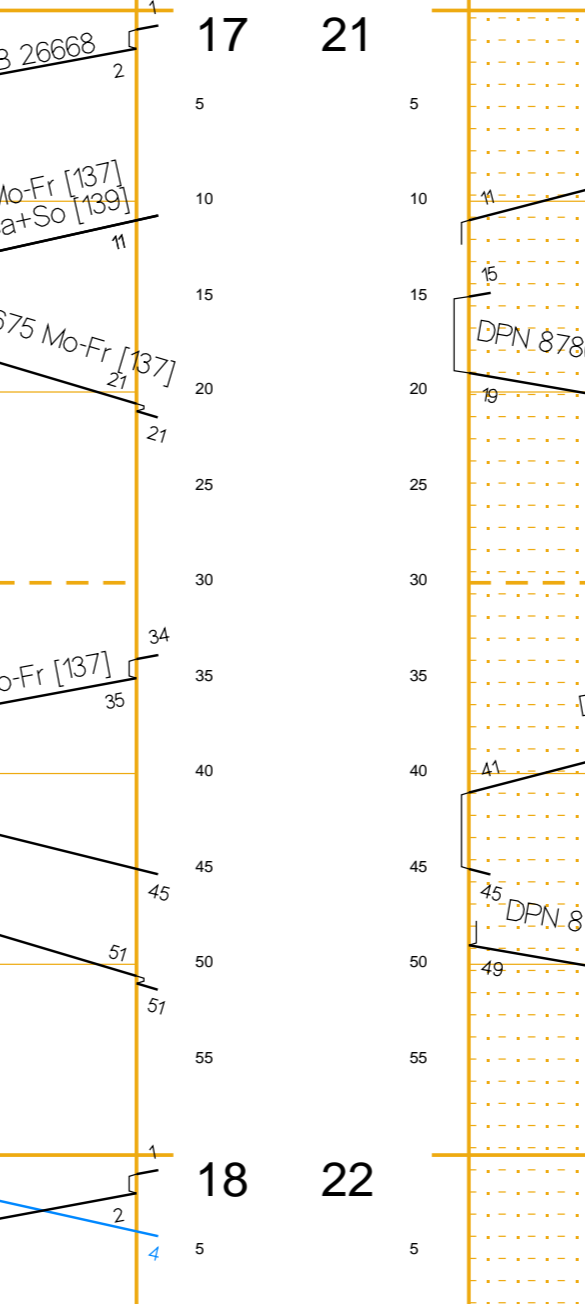
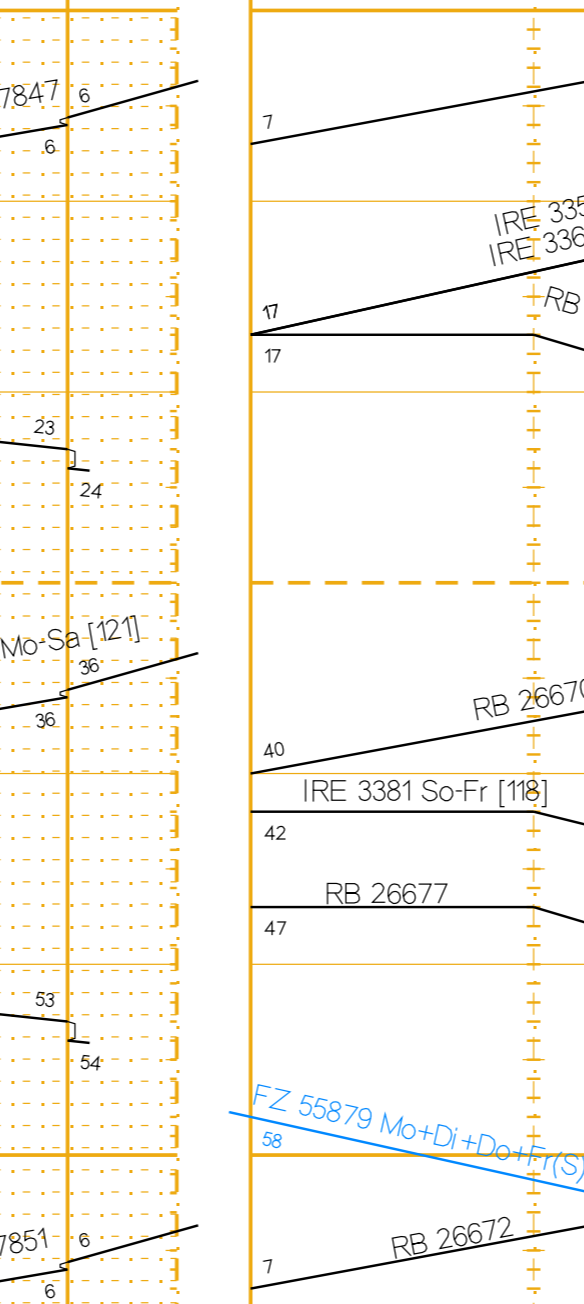
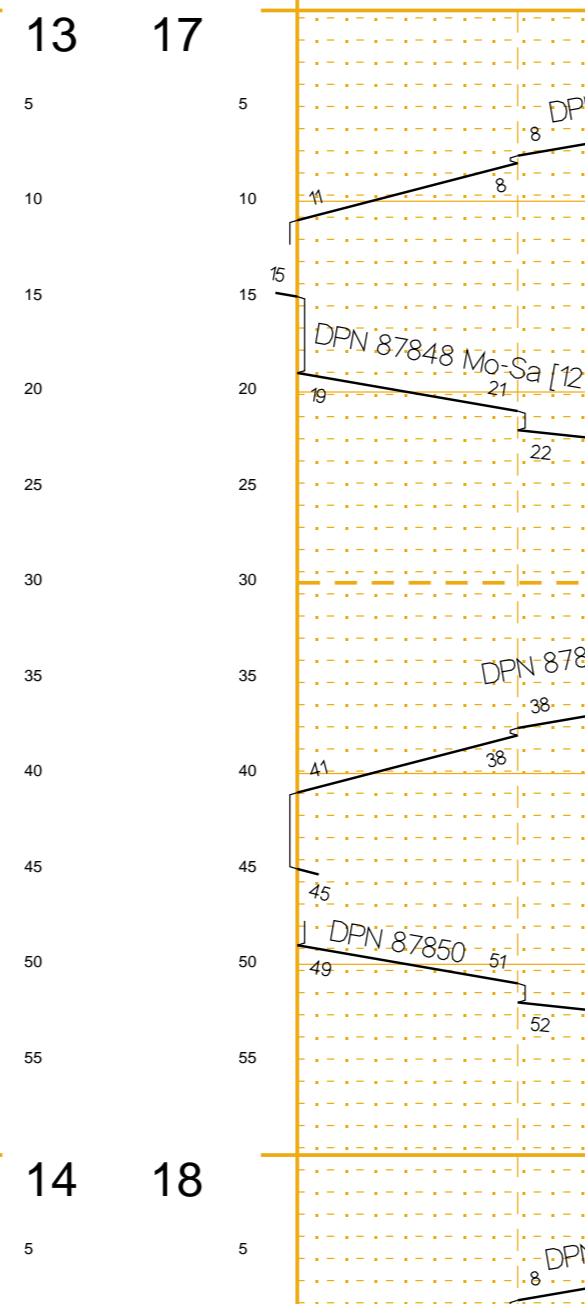
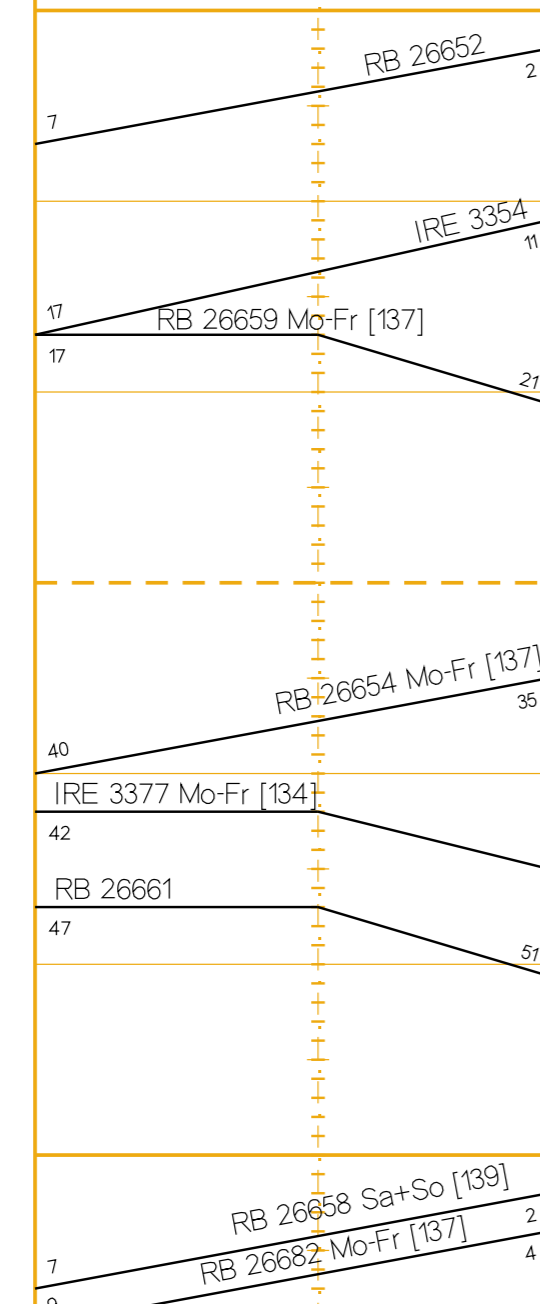
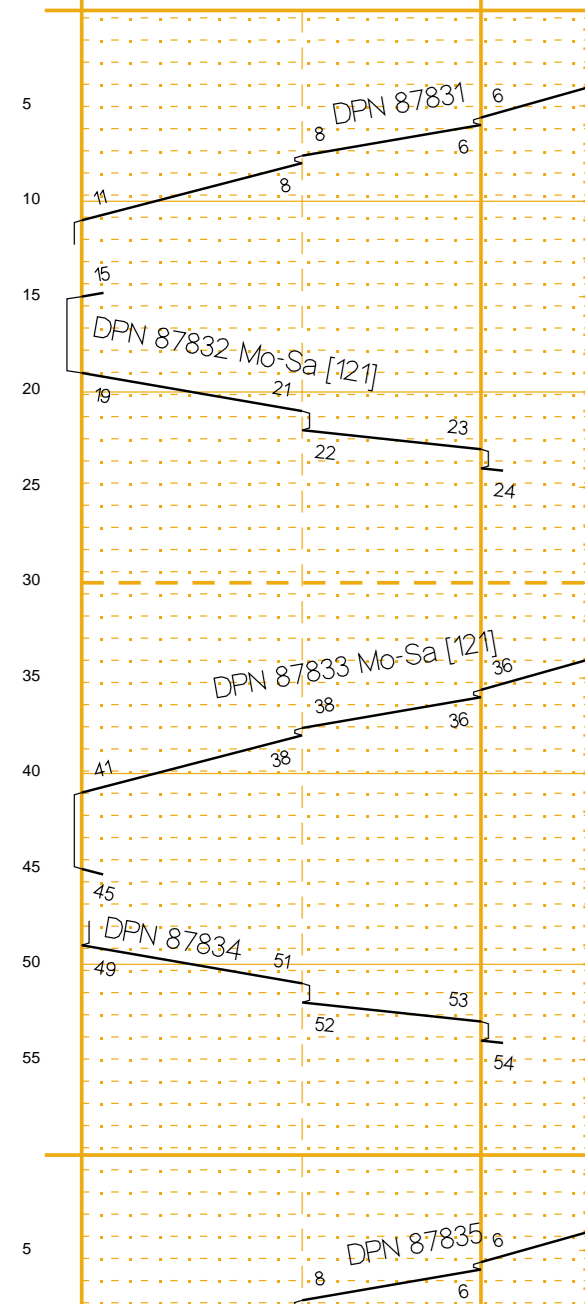
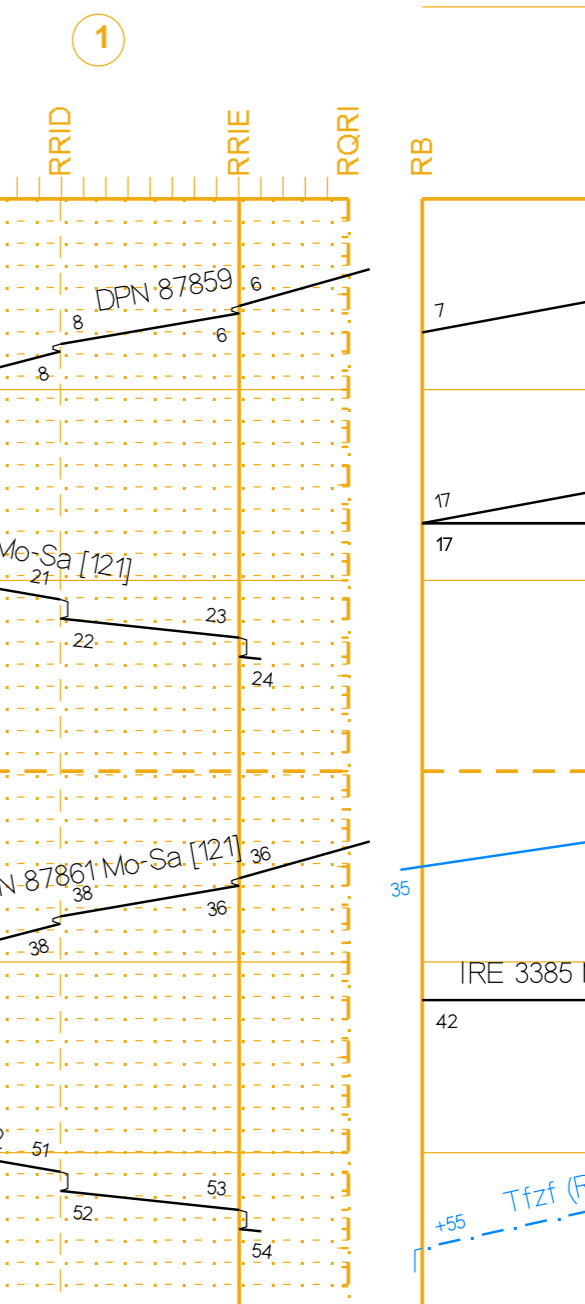
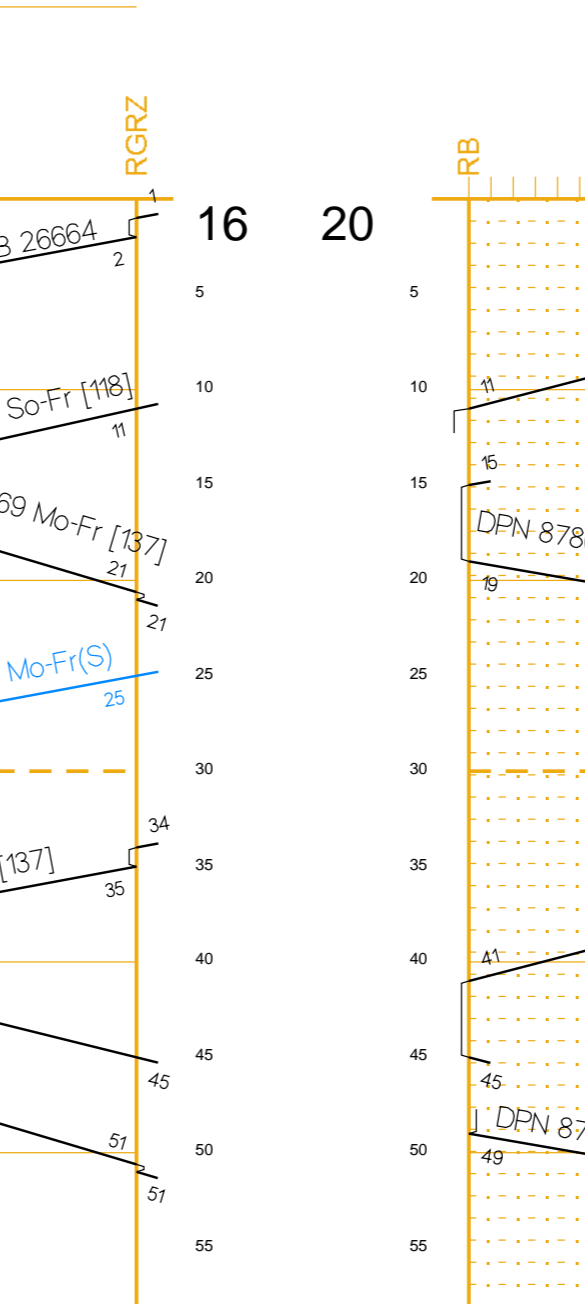
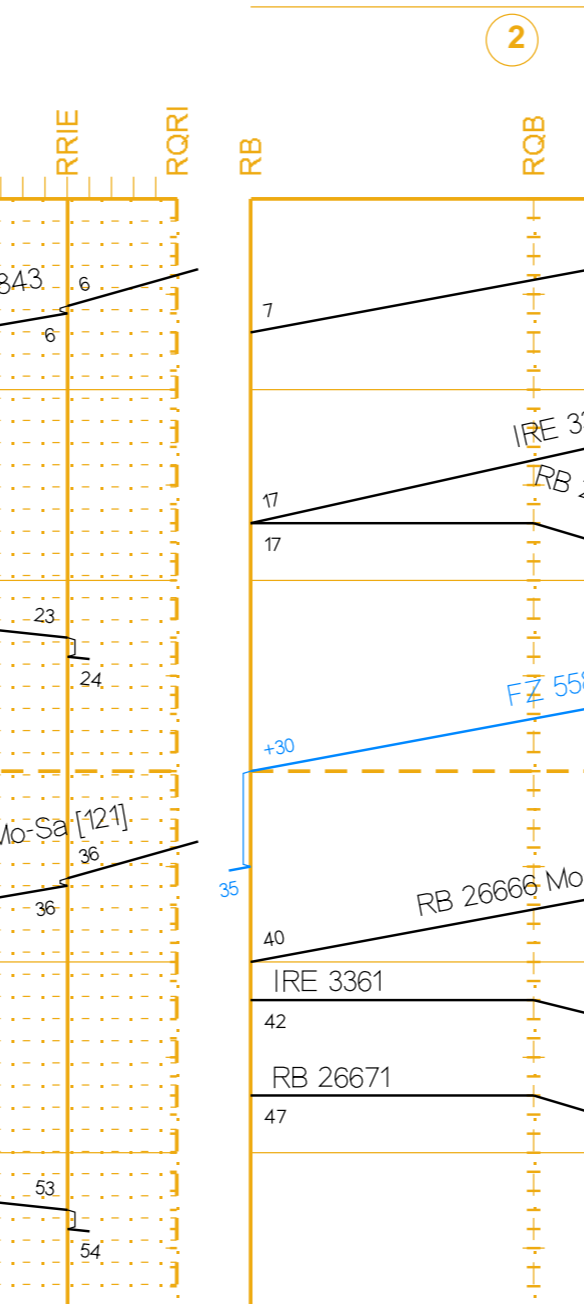
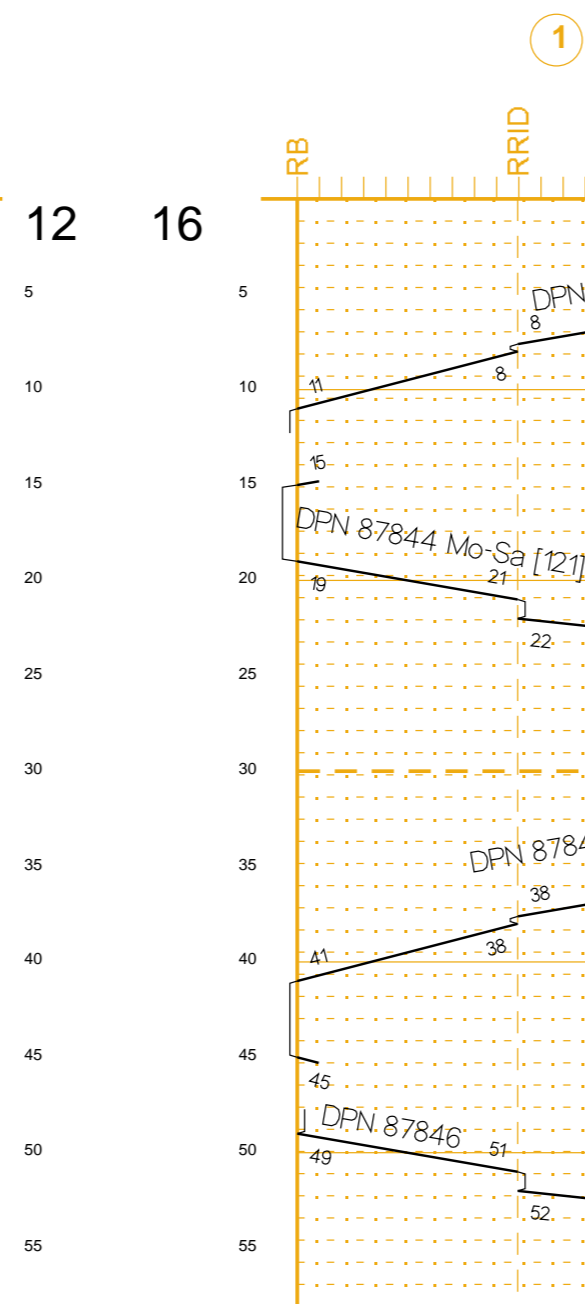
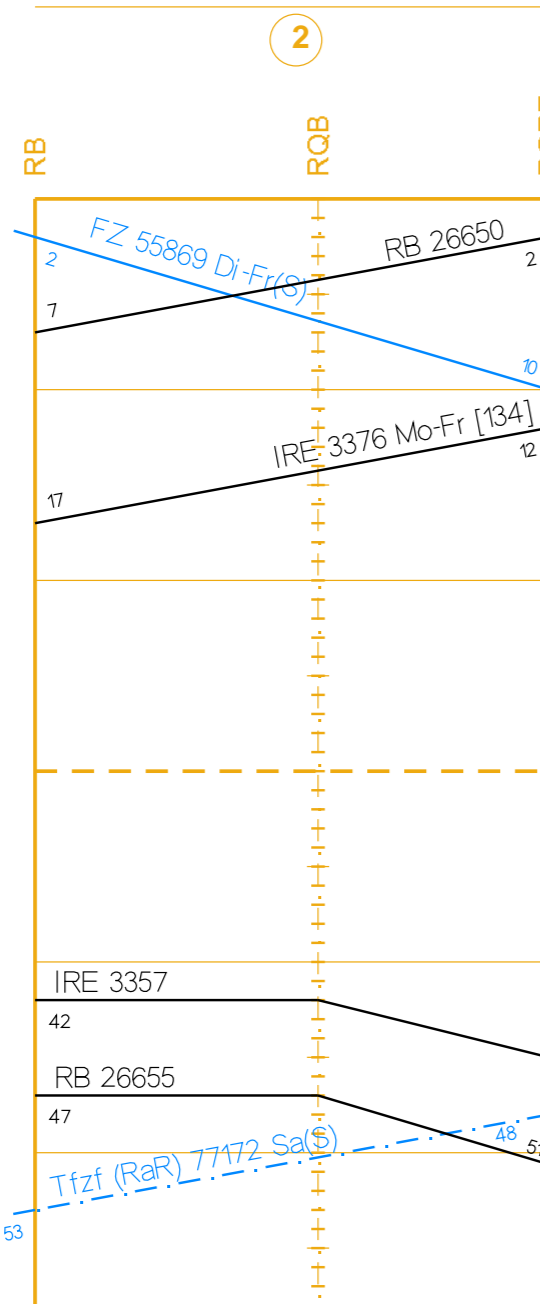
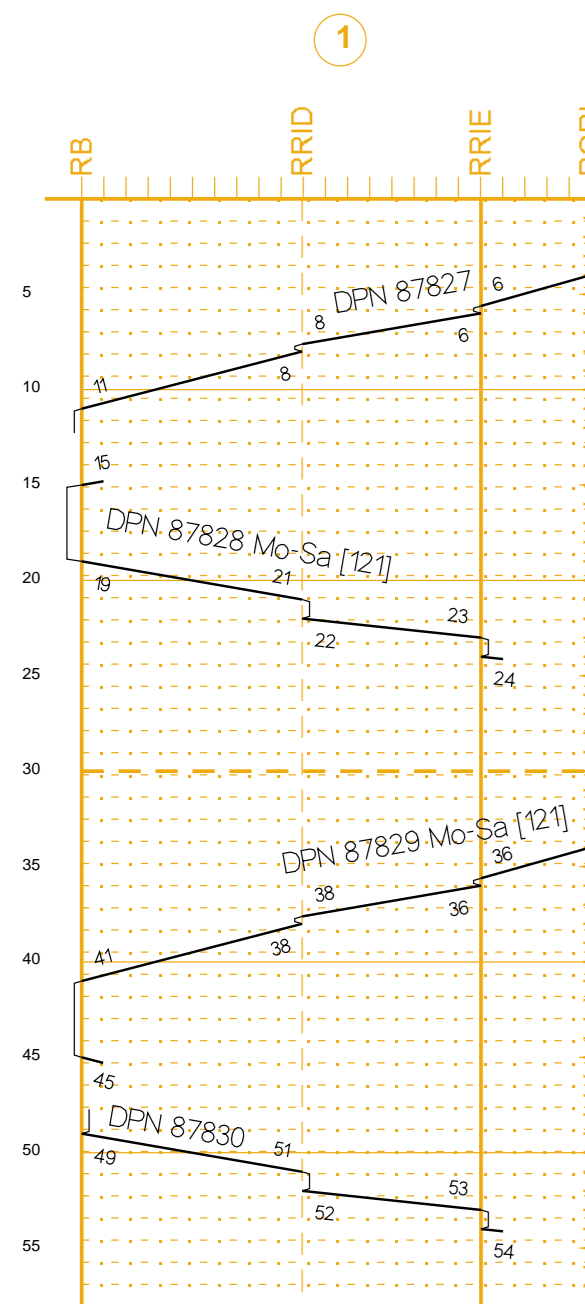
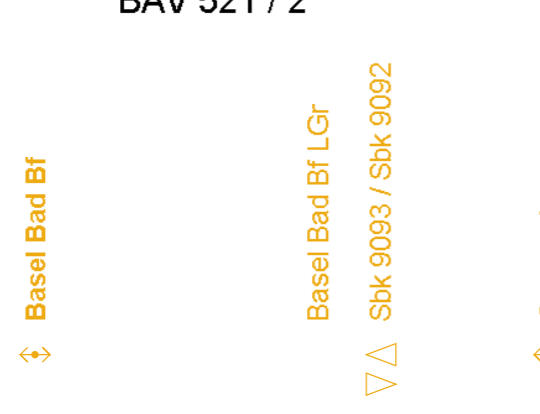

[104] nicht: 24.12.10, 25.12.10, 26.12.10, 1.1.11
 [140] nicht: 6.1.11
 [118] nicht: 24.12.10, 31.12.10
 auch: 22.12.10, 26.12.10, 2.1.11
 auch: 25.12.10, 1.1.11
 [121] nicht: 25.12.10, 1.1.11
 [134] nicht: 24.12.10, 31.12.10, 1.1.11
 auch: 3.1.11
 [135] nicht: 25.12.10
 [136] nicht: 25.12.10, 1.1.11
 auch: 24.12.10, 31.12.10, 6.1.11
 [137] nicht: 24.12.10, 31.12.10, 6.1.11
 auch: 24.12.10, 31.12.10, 6.1.11