

Gland	33.79
Prangins	37.04
Nyon	38.53
d/p St-Cergue	3.39
Bois-Bougy	0.74
Charlemont	0.79
Crans	1.38
Murat (diag)	2.17
Céligny	1.22
Founex	1.24
Coppet	1.60
Tannay	1.85
Mies	0.89
Pont-Céard	1.85
Versoix	0.97
Creux-de-Genthod	0.97
Genthod-Bellevue	0.43
Les Tuileries	0.41
Vengeron (diag)	2.25
Chambésy	58.87
Pregny	0.53
Genève-Sécheron	59.40
Genève Poste 1	0.86
Genève	60.26

Genève Poste 1	59.40
Genève Faisceau C	0.20
Genève	0.67
Genève	60.27
Genève	60.26

Genève Poste 1	59.40
Genève Faisceau B	0.20
Genève	0.64
Genève	60.24

Genève	60.26
St-Jean (bif)	1.34
Châtelaine (bif)	2.38
Genève-Aéroport	2.20
Genève-Aéroport	66.18

St-Jean (bif)	61.60
Jonction (Genève)	0.80
Jonction (Genève)	62.40

Genève	60.26
St-Jean (bif)	1.34
Jonction (Genève)	0.80
Jonction (Genève)	62.40
Lancy-Pont-Rouge	1.49
Genève-La Praille	0.65
Genève-Stade	0.71
Genève-Stade	65.25

Genève-La Praille	64.54
Genève-La Praille	3.08
Furet (bif)	62.59

Genève	60.26
St-Jean (bif)	2.34
Furet (bif)	61.59
Furet (bif)	62.59
Châtelaine (bif)	1.38
Châtelaine (bif)	63.97
Cointrin	0.80
Vernier-Meyrin Cargo	0.66
Vernier-Meyrin	0.68
Vernier-Meyrin	66.11
Zimeysa	0.87
Zimeysa	66.98
Zimeysa	2.39

Satigny	69.37
Satigny	3.46
Russin	72.83
La Plaine	1.94
La Plaine-Frontière	74.77
La Plaine-Frontière	75.55

Pougny-Chancy	77.55
Fort-l'Ecluse	77.55
Longeray (bif)	77.55

Bellegarde	77.55
------------	-------

Altitude au dessus de la mer RPN = 373.60

Profil en long

Pente maximum

Rampe maximum

Situation des stations, bifurcations, plus longues voies d'évitement

Stations de block

Distance de stat. a stat.

Kilométrage de la voie

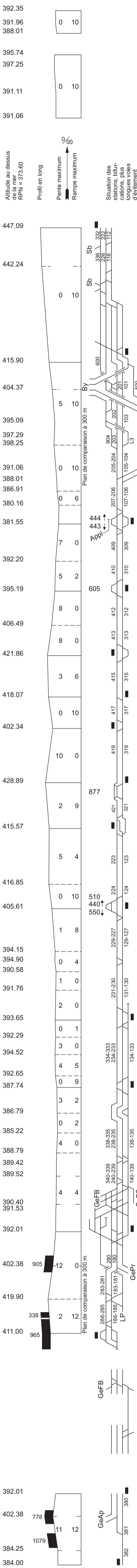

Stations de block	Distance de stat. à stat.	Kilométrage de la voie
Lausanne	0.00	
Lausanne (bif)	1.13	1.13
Malley	3.38	
Renens VD	4.51	
d/p Daillens	1.80	
Archy (bif)	6.31	
Venoge	1.72	8.03
Denges B (bif)	0.24	8.27
Denges A (bif)	0.11	8.38
Denges	1.33	
Lonay B (bif)	0.29	9.71
Lonay A (bif)	0.12	10.00
Lonay-Préverenges	1.04	10.12
Morges-St-Jean	1.34	11.16
Morges	2.22	12.50
d/p Apples		
Tolochenaz	2.19	14.72
St-Prex	2.43	16.91
Etoy	2.13	19.35
Allaman	2.91	21.48
Perroy	2.27	24.39
Rolle	3.84	26.66
Gilly-Bursinel	3.28	30.51
Gland	3.25	33.79
Prangins	1.48	37.04
Nyon	3.39	38.53
d/p St-Cergue		
Bois-Bougy	0.74	41.92
Charlemont	0.79	42.66
Crans	1.38	43.45
Murat (diag)	2.17	44.83
Céligny	1.22	47.00
Founex	1.24	48.22
Coppet	1.60	49.46
Tannay	0.89	51.06
Mies	1.85	51.95
Pont-Céard	0.97	53.80
Versoix	0.97	54.77
Creux-de-Genthod	0.43	55.78
Genthod-Bellevue	0.41	56.21
Les Tuileries	2.25	56.62
Vengeron (diag)		
Chambésy	0.53	58.87
Pregny	0.86	59.40
Genève-Sécheron	1.34	60.26
Genève Poste 1	2.38	61.60
Genève	2.20	63.98
St-Jean (bif)		
Châtelaine (bif)		
Genève-Aéroport		
Genève Poste 1	0.20	59.40
Genève faisceau C	0.67	59.60
Genève	60.27	60.26
Genève Poste 1	0.20	59.40
Genève faisceau B	0.64	59.60
Genève	1.34	60.24
St-Jean (bif)	1.34	60.26
Jonction (Genève)	0.80	61.60
Lancy-Pont-Rouge	1.49	62.40
Genève-La Praille	0.65	63.89
		64.54

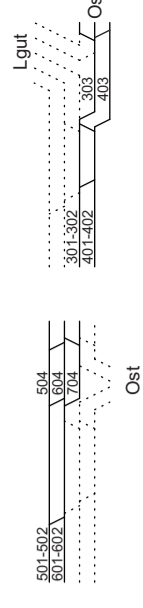
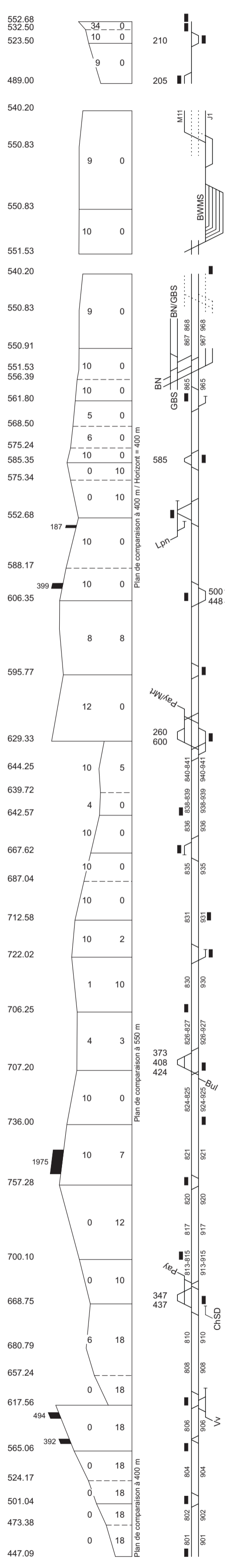

Bern Wylerfeld

Gl. 300 / 400

Bern

Bern Wylerfeld

Gl. 500 / 600

Bern

Flamatt
Flamatt Dorf
Neuenegg

0.68	0.00
1.04	1.72
5.08	

Laupen

6.80	
------	--

Bern

Gleise G

Bern JKLM

0.86	97.18
------	-------

Bern Weyermannshaus

1.32	
------	--

0.42	95.00
------	-------

Bern Steigerhubel (Abzw)

94.58	
-------	--

Bern

Gleise P

Bern JKLM

0.86	97.18
------	-------

96.32	
-------	--

Bern Weyermannshaus (Spw)

1.41	
------	--

Bern Steigerhubel (Abzw)
Bern Ausserholligen SBB

0.34	94.92
0.47	94.11

Bern Bümpliz Süd

1.12	93.00
------	-------

Niederwangen

1.95	91.04
------	-------

Oberwangen

1.67	89.37
------	-------

Thörishaus Station

1.17	88.20
------	-------

Thörishaus Dorf

1.32	86.88
------	-------

Flamatt
v/n Laupen

2.81	84.07
------	-------

Wünnewil

3.73	80.34
------	-------

Schmitten

2.48	77.86
------	-------

Düdingen

5.65	72.21
------	-------

Grandfey

6.22	65.99
------	-------

d/p Givisiez (Pay / Mrt)

Fribourg

6.22	65.99
------	-------

Glâne

2.81	84.07
------	-------

Villars-sur-Glâne

3.73	80.34
------	-------

Matran

2.48	77.86
------	-------

Rosé

5.65	72.21
------	-------

Neyruz

6.22	65.99
------	-------

Cottens

2.81	84.07
------	-------

Chénens

3.73	80.34
------	-------

Villaz-St-Pierre

2.48	77.86
------	-------

Romont

5.65	72.21
------	-------

d/p Bulle

6.22	65.99
------	-------

Siviriez

2.81	84.07
------	-------

Vauderens

3.73	80.34
------	-------

Oron

5.65	72.21
------	-------

d/p Payerne

6.22	65.99
------	-------

Palézieux

2.48	77.86
------	-------

d/p Châtel-St-Denis

3.73	80.34
------	-------

Corbéron

5.65	72.21
------	-------

Moreillon

6.22	65.99
------	-------

Puidoux-Chexbres

2.46	14.62
------	-------

d/p Vevey

3.85	12.16
------	-------

Grandvaux

3.85	12.16
------	-------

Bossière

2.53	8.31
------	------

La Conversion

1.77	5.78
------	------

Pully-Nord

1.64	4.00
------	------

Lausanne

2.37	2.37
------	------

d/p St-Maurice

2.37	0.00
------	------

Lausanne

d/p Renens

2.37	0.00
------	------

Altitude au dessus de la mer
RPN = 373.60

Profil en long

Pente maximum
Rampe maximum

Situation des stations, bifurcations, plus longues voies d'évitement

Stations de block

Distance de stat. à stat.

Kilométrage de la voie

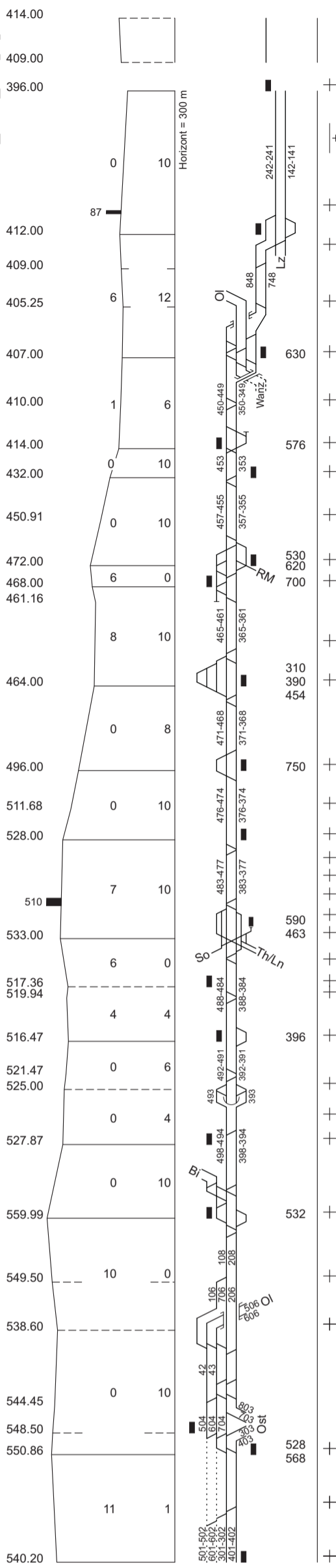

v/n Luzern

Aarburg-Ofringen Süd (Abzw)	00.83
Aarburg-Ofringen West (Abzw)	00.00
Olten	39.29
Aarburg-Ofringen	43.01
Aarburg-Ofringen West (Abzw)	43.97
Bifang AG (Spw)	44.86
Rothrist	46.20
Rothrist Hungerzelg Rank (Spw)	49.07
Murgenthal Roggwil-Wynau	52.22
Gurtelen	54.49
Langenthal	59.11
Langenthal GB	59.19
Langenthal West (Abzw)	60.38
Herzogenbuchsee	61.26
Riedwil	66.42
Lochmatt	66.50
Wynigen	66.79
Burgdorf	72.33
Lyssach Sandacher (Spw)	76.93
Hindelbank	83.39
Hardfeld (Spw)	86.54
Mattstetten (Abzw)	87.20
Schönbühl SBB	89.73
Zollikofen	91.66
Rütli (Abzw)	91.98
Löchligut	94.91
Löchligut Süd (Abzw)	98.81
Bern Wankdorf	100.20
Bern Wylerfeld	100.22
Lorraine	101.28
Bern	102.50
Bern JKLM	102.94
Bern	103.33
Bern JKLM	106.13

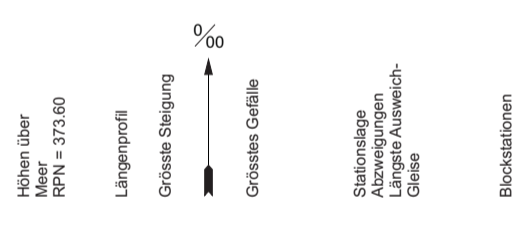

Gleise P (J2, J7, J8)	
Bern JKLM	
Bern	
Gleise G (J1, M1)	
Bern JKLM	

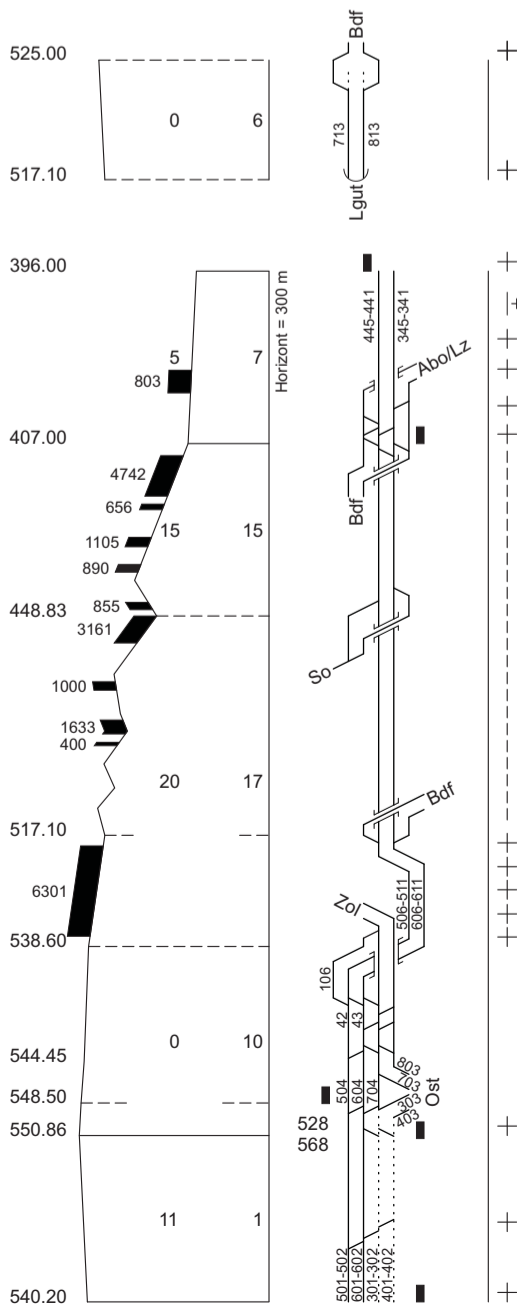

v/n Luzern

Mattstetten (Abzw)	92.09
Aespli	92.77
Olten Nord-Ost (Abzw)	12.28
Olten	39.29
Rothrist	45.15
v/n Burgdorf	46.20
Wanzwil (Abzw)	47.35
v/n Solothurn	55.29
Aespli	19.39
Wanzwil (Abzw)	36.98
Aespli	24.71
Löchligut	7.43
Löchligut Süd (Abzw)	12.28
Bern Wankdorf	4.85
Bern Wylerfeld	101.28
Lorraine	1.22
Bern	102.50
Bern JKLM	102.94
Bern	103.33
Lorraine	2.80
Bern	106.13



Gleise P (J2, J7, J8)	
Bern JKLM	
Bern	
Gleise G (J1, M1)	
Bern JKLM	

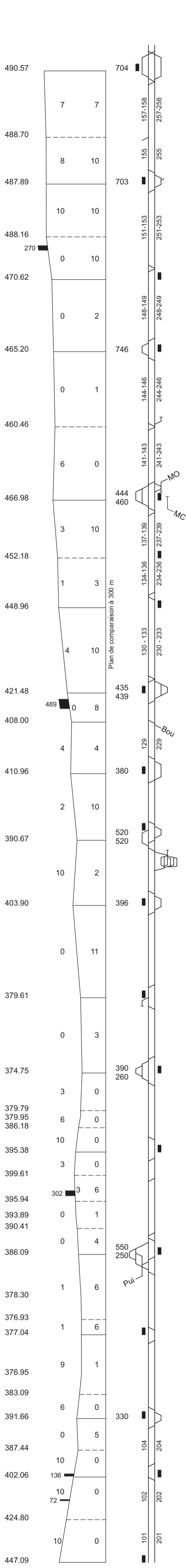

Station	Altitude (m)	Distance (km)
Lausanne	447.09	0.00
Pully	402.06	2.51
Lutry	402.06	5.07
Villette VD	387.44	6.68
Cully	391.66	8.52
Epresses	383.09	9.98
Dézaley	376.95	13.55
Rivaz	377.04	14.55
St-Saphorin	376.93	17.66
Roseville	378.30	18.40
Vevey	386.09	17.64
d/p Puidoux-Chexbres	386.09	17.66
Vevey	386.09	18.40
d/p Blonay	390.41	19.90
La Tour-de-Peilz	390.41	19.90
Tour-de-Peilz	393.89	21.53
Burier	395.94	21.53
Clarens	399.61	23.10
d/p Caux	399.61	23.10
Montreux	395.38	24.54
d/p Montbovon	395.38	24.54
Territet	386.18	26.02
Veytaux	379.95	26.02
Veytaux-Chillon	379.79	27.09
Villeneuve	374.75	29.34
Roche VD	379.61	33.84
Aigle	403.90	39.31
d/p Les Diablerets (4..)	403.90	39.31
d/p Leysin (2..)	403.90	39.31
d/p Champéry	403.90	39.31
St-Triphon	390.67	43.60
Bex	410.96	47.56
d/p Villars	410.96	47.56
Bex	410.96	47.56
Les Paluds	408.00	50.07
d/p Bouveret	408.00	50.07
St-Maurice	421.48	51.56
Evionnaz	448.96	57.85
Vernayaz	452.18	61.51
Martigny	466.98	66.50
d/p Le Châtelard-Frontière	466.98	66.50
d/p Orsières	466.98	66.50
Charrat-Fully	460.46	70.86
Saxon	465.20	75.27
Riddes	470.62	79.57
Chamoson	488.16	82.12
Ardon	487.89	85.31
Châteauneuf-Conthey	488.70	88.07
Sion	490.57	92.43

Altitude au dessus de la mer
RPN = 373.60

Profil en long

Pente maximum

Rampe maximum

Situation des stations, bifurcations, plus longues voies d'évitement

Stations de block

Distance de stat. à stat.

Kilométrage de la voie

d/p Palézieux

Lausanne

d/p Renens

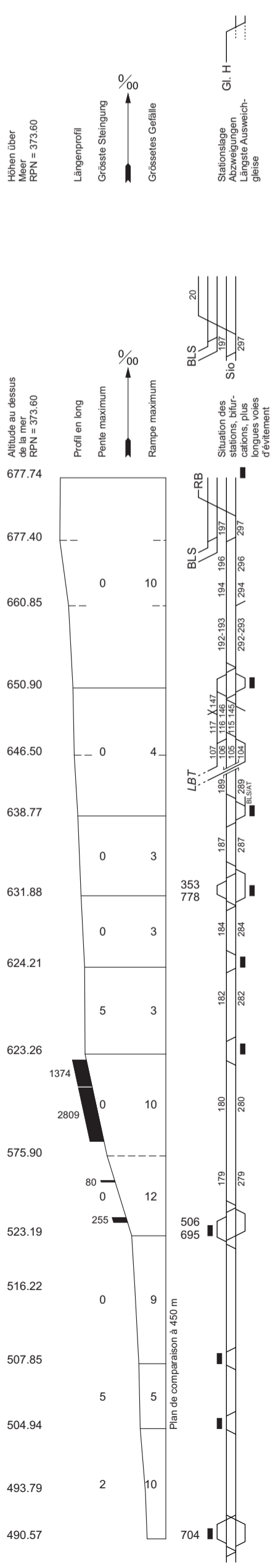
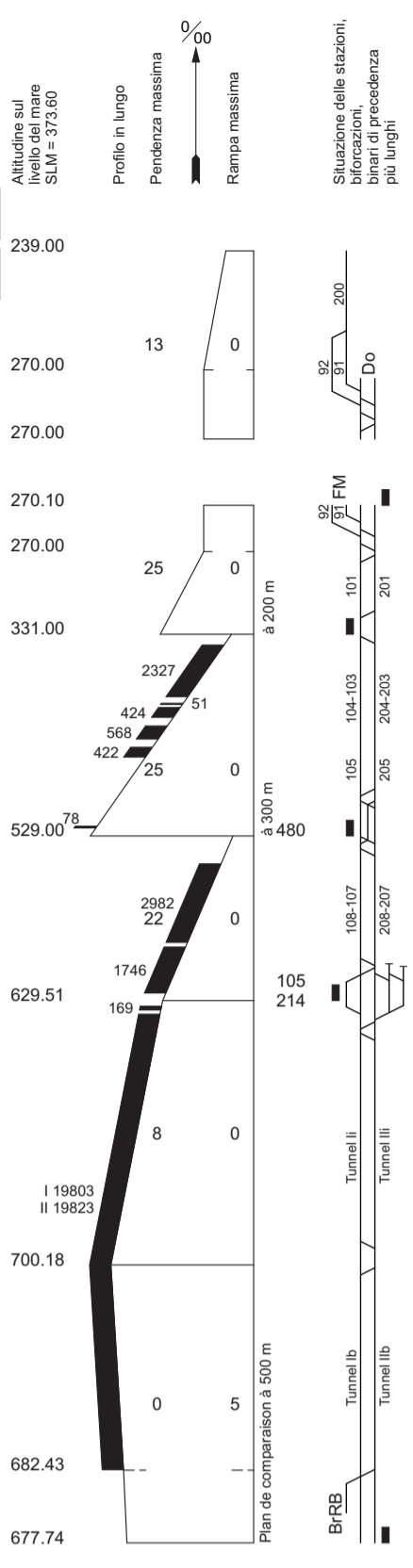

Stazioni di blocco	Distanza da stazione a stazione	Chilometraggio del binario
d/p Milano		
d/p Locarno		
Domodossola		
Domodossola II	5.23	0.00
Domodossola FM	1.08	5.23
Domodossola (bif)		6.31 1.24
Domodossola		
Domodossola (bif)	1.24	0.00
	2.59	1.24
Preglia		
<i>Rio Rido</i>		3.83
<i>Mognatta</i>		8.72
Varzo		
		12.55
<i>Galleria elicoïdale</i>		6.25
Iselle di Trasquera		
		18.80 167.48
		11.47
Staz. della Galleria Sempione		
		156.01
		8.86
Brig Tunnel		147.15
Brig		
Brig Tunnel		145.55
		147.14
		0.59
Brig RB		
v/n Furka		146.55
Brig		
v/n Zermatt		146.55
Brig RB		
		1.30
Brig Lötschberg (Abzw)		145.25
Brig		
v/n Thun		145.55
Brig		
		0.30
Brig Lötschberg (Abzw)		145.25
<i>Gliser Grund</i>		3.81
Gamsen SBB		141.44
		4.71
Visp		
v/n Zermatt		136.73
		3.45
St. German (Abzw)		133.28 50.06
		3.19
Raron		
		130.09
		4.22
Gampel-Steg		
		125.87 125.86
		3.75
Turtmann		
		122.11
		4.49
Leuk		
		118.83 118.80 117.58
		5.33
Salgesch		112.25
		4.12
Sierre/Siders		
		108.13
<i>Noës</i>		6.57
Granges-Lens		
		101.56
		3.40
St-Léonard		
<i>Clavoz</i>		98.15
		5.72
Sion		
		92.43
d/p St-Maurice		

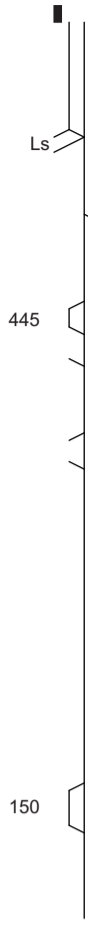
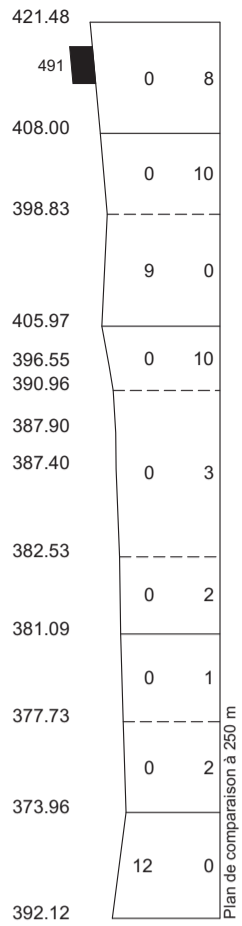

d/p Sion

+	St-Maurice		51.56
+	Les Paluds d/p Lausanne	1.50	50.07 1.47
+	Massongex	1.73	3.20
		2.85	
+	Monthey		6.05
	Monthey Giovanola (embr)	1.16	7.21
	Collombey	0.70	7.91
	Monthey centre agr Bas-Valais (embr)	1.18	9.09
	Monthey AGIP (embr)	1.00	10.09
		3.30	
	Vionnaz		13.39
		2.87	
	Vouvry		16.25
		3.27	
	Les Evouettes		19.53
		3.39	
+	Bouveret		22.91
		3.89	
	St-Gingolph (Suisse)		26.80

d/p Lausanne

Vevey

d/p Sion

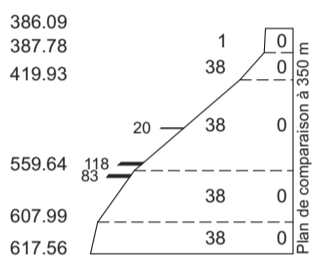

+	Vevey		0.00
	Vevey-Funi	0.85	0.85
	Corseaux-Cornalles	0.90	1.75
		3.86	
	Chexbres-Village		5.61
	Le Verney (embr)	1.49	7.10
+	Puidoux-Chexbres	0.73	7.83

Altitude au dessus
de la mer
RPN = 373.60

Profil en long

Pente maximum
Rampe maximum

Situation des
stations, bifur-
cations, plus
longues voies
d'évitement

Stations de block

d/p Lausanne

Puidoux-Chexbres

Distance de
stat. à stat.

Kilométrage
de la voie

d/p Palézieux

d/p Sion

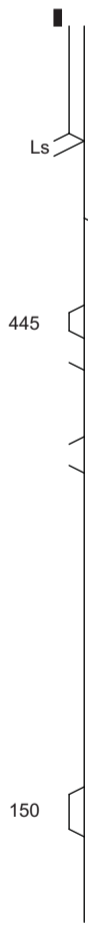
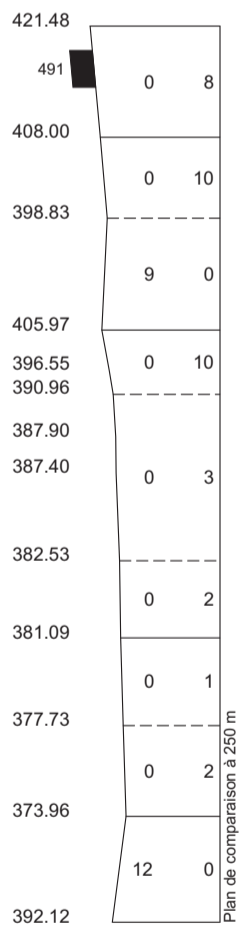

+	St-Maurice		51.56
+	Les Paluds d/p Lausanne	1.50	50.07 1.47
+	Massongex	1.73	3.20
		2.85	
+	Monthey		6.05
	Monthey Giovanola (embr)	1.16	7.21
	Collombey	0.70	7.91
	Monthey centre agr Bas-Valais (embr)	1.18	9.09
	Monthey AGIP (embr)	1.00	10.09
		3.30	
	Vionnaz		13.39
		2.87	
	Vouvry		16.25
		3.27	
	Les Evouettes		19.53
		3.39	
+	Bouveret		22.91
		3.89	
	St-Gingolph (Suisse)		26.80

d/p Lausanne

Vevey

d/p Sion

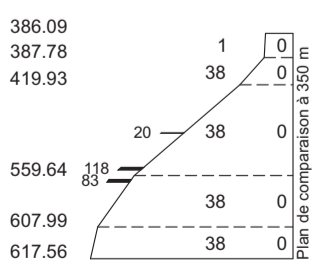

+	Vevey		0.00
	Vevey-Funi	0.85	0.85
	Corseaux-Cornalles	0.90	1.75
		3.86	
	Chexbres-Village		5.61
	Le Verney (embr)	1.49	7.10
+	Puidoux-Chexbres	0.73	7.83

Altitude au dessus
de la mer
RPN = 373.60

Profil en long

Pente maximum
Rampe maximum

Situation des
stations, bifur-
cations, plus
longues voies
d'évitement

Stations de block

d/p Lausanne

Puidoux-Chexbres

Distance de
stat. à stat.

Kilométrage
de la voie

d/p Palézieux

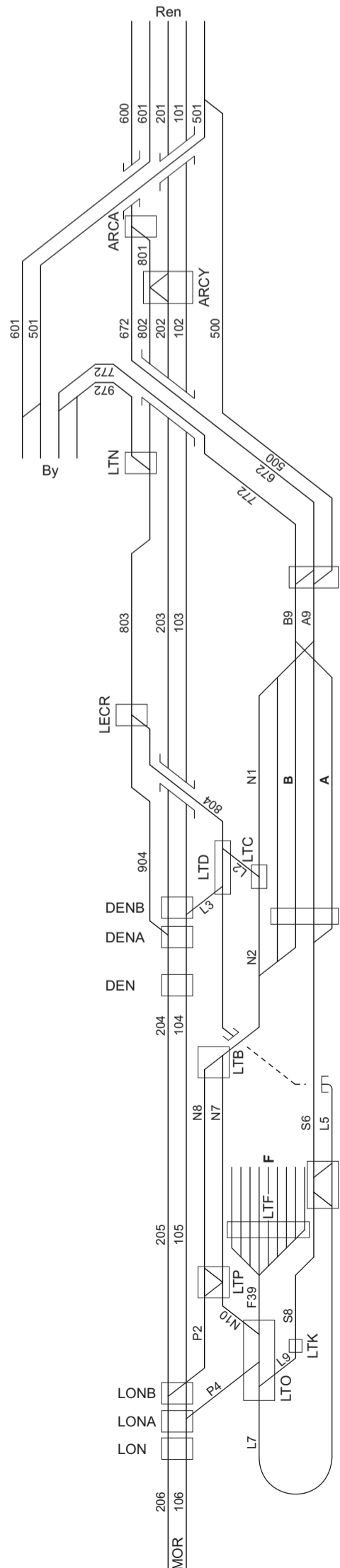
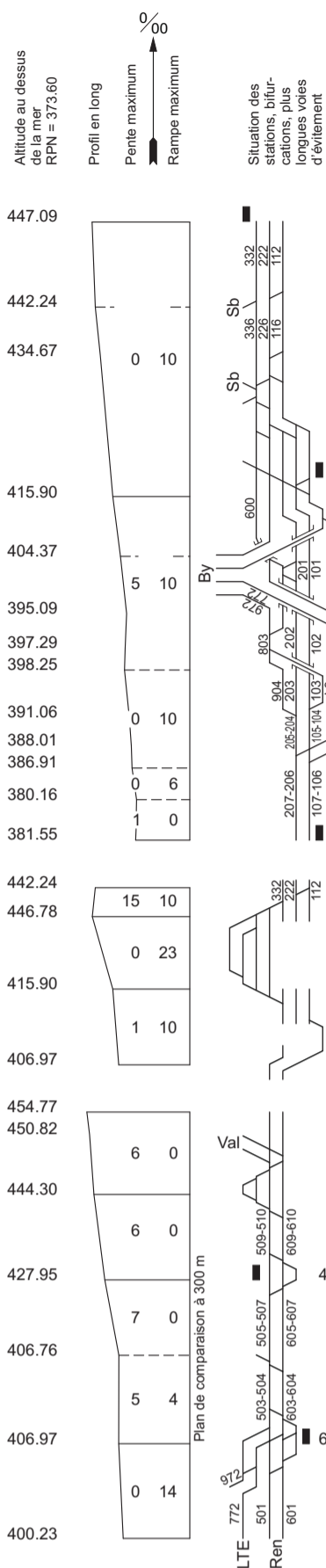

d/p Vevey

Lausanne

d/p Palézieux

Lausanne

Lausanne

Lausanne (bif)

Malley

Renens VD

d/p Daillens

Archy (bif)

Venoge

Denges B (bif)

Denges A (bif)

Denges-Echandens

Denges

Lonay B (bif)

Lonay A (bif)

Lonay-Préverenges

Morges-St-Jean

Morges

Lausanne (bif)

Lausanne-Sébeillon

Renens VD

Bussigny

Eclépens

Eclépens sud

d/p Vallorbe

Daillens

Vaux

Cossonay

Gollion

Vufflens-la-Ville

Fallien

Bussigny

d/p LTN voie 972

voie 772

Lausanne-Triage Est

Renens VD

voie 500

Lausanne-Triage Est

Renens VD

voie 600

Archy A (bif)

voie 672

Lausanne-Triage Est

Lausanne-Triage A/B

Lausanne-Triage B

voie N1

Lausanne-Triage C

voie N2

Lausanne-Triage B

voie N7/8

Lausanne-Triage P1

Lausanne-Triage Ouest

Lonay A (bif)

voie N10

voie P4

Lausanne-Triage A/B

voie S6

Lausanne-Triage Sud

voie P4

Lausanne-Triage K

voie L9

Lausanne-Triage Ouest

voie P2

Lonay B (bif)

Bussigny

voie 972

Lausanne-Triage Nord

voie L2

Lausanne-Triage D

voie L3

Denges B (bif)

Denges A (bif)

voie 904

Lécheires (bif)

Renens VD

voie 600

Archy A (bif)

Archy (bif)

voie 802

Lausanne-Triage Nord

voie 803

Lécheires (bif)

voie 804

Bosse

Lausanne-Triage Sud

Praz Lebaz

voie L7

Record Buchet

Lausanne-Triage Ouest

Lausanne-Triage F

voie L7

Distance de stat. a stat.	Kilométrage de la voie
1.13	0.00
1.13	1.13
3.38	
4.51	
1.80	4.51
1.72	6.31
8.03	
0.24	8.27
0.11	8.38
1.33	
0.29	9.71
0.12	10.00
1.04	10.12
1.34	11.16
1.34	12.50
0.39	1.13
1.52	
2.99	
4.51	
2.42	
6.93	
21.38	
20.59	
2.18	
18.41	
3.92	
14.49	
3.51	
10.97	
4.05	
6.93	
14.92	
1.53	
13.39	
4.51	
2.61	
7.12	
4.51	
1.40	
5.91	
1.35	
7.26	
7.12	
0.98	
8.10	
0.40	
8.50	
7.12	
0.84	
7.96	
0.54	
8.50	
0.91	
9.41	
0.31	
9.72	
9.70	
10.00	
0.30	
8.10	
0.84	
9.38	
8.94	
11.59	
0.70	
10.89	
0.24	
10.65	
9.40	
0.30	
9.70	
14.92	
1.08	
13.84	
7.96	
0.26	
7.70	
7.72	
0.31	
8.03	
8.27	
0.91	
7.36	
4.51	
1.40	
5.91	
0.22	
6.12	
0.62	
6.75	
13.84	
0.63	
13.21	
0.36	
12.85	
1.37	
11.48	
1.67	
9.81	
0.51	
9.72	

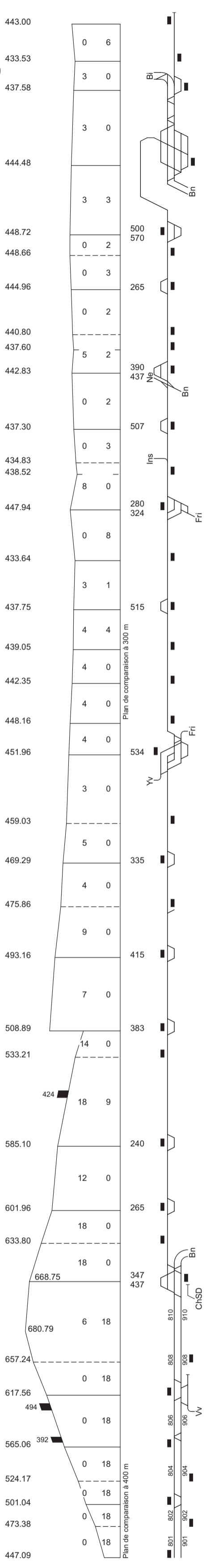

+	Büren an der Aare	95.71
	Dotzigen	3.48
	v/n Biel/Bienne	99.19
+	Busswil	2.67
		101.86
		26.16
		2.79
+	Lyss	
	v/n Bern	23.37
		23.60
		100.42
		5.16
+	Aarberg	
	Bargen	95.49
		1.56
		93.94
+	Kallnach	
		2.57
		91.37
		3.70
	Fräschels	87.67
	Kerzers Papiliorama	1.17
	v/n Neuchâtel	87.69
	Kerzers	1.71
	v/n Bern	86.52
		84.81
		4.14
+	Galmiz	
		80.67
	v/n Ins	1.58
+	Muntelier	
	Muntelier-Löwenberg	79.09
		0.52
		78.57
+	Murten	
	d/p Fribourg	2.05
		76.52
		3.72
+	Faug	
		72.80
		3.69
+	Avenches	
		69.12
		2.93
+	Domdidier	
		66.19
		2.53
+	Dompierre	
		63.66
		2.90
+	Corcelles-Nord	
	d/p Fribourg	60.76
	Payerne	2.34
	d/p Yverdon-les-Bains	59.45
		59.50
		58.47
		5.06
	Trey	53.41
		2.96
+	Granges-Marnand	
		50.44
		3.26
	Henniez	47.18
		3.80
+	Lucens	
		43.38
		5.41
+	Moudon	
	Bressonaz	37.98
		1.91
		36.07
		5.45
+	Ecublens-Rue	
		30.61
		4.72
+	Châtillens	
		25.89
		2.48
	Palézieux-Village	23.41
	d/p Bern	2.81
+	Palézieux	
	d/p Châtel-St-Denis	20.60
	Corbéron	5.98
+	Moreillon	
		14.62
		2.46
+	Puidoux-Chexbres	
	d/p Vevey	12.16
		3.85
+	Grandvaux	
		8.31
		2.53
+	Bossière	
		5.78
+	La Conversion	
		1.77
		4.00
+	Pully-Nord	
		1.64
		2.37
+	Lausanne	
		2.37
		0.00

Altitude au dessus de la mer = 373.60 RPN

Profil en long
Pente maximum
Rampe maximum

Situation des stations, bifurcations, plus longues voies d'évitement

Stations de block

d/p Vevey

Lausanne

Distance de stat. à stat.

Kilométrage de la voie

d/p Renens

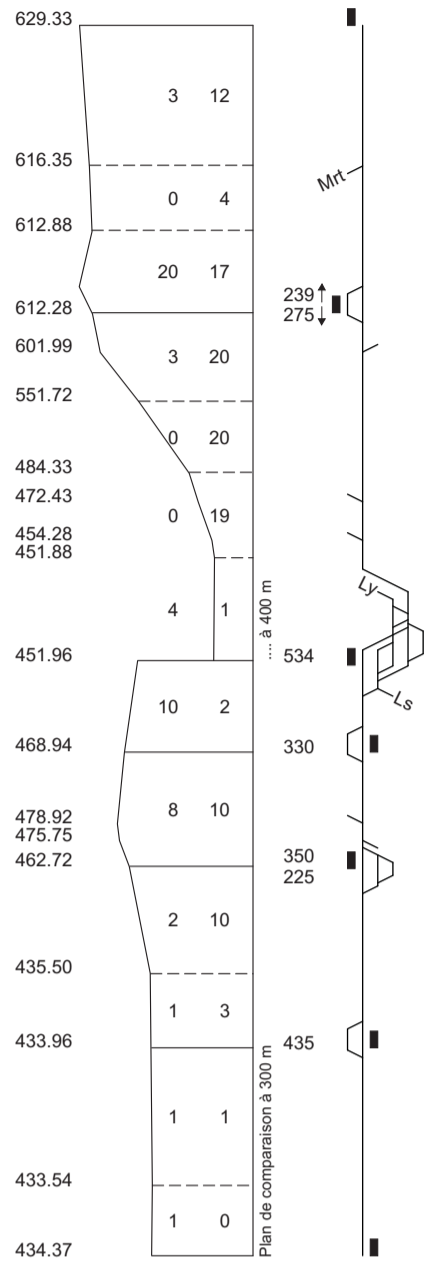

Altitude au dessus de la mer, RPN = 373.60
Profil en long
Pente maximum
Rampe maximum
Situation des stations, bifurcations, plus longues voies d'évitement

d/p Lausanne

Fribourg

d/p Bern

Fribourg

	49.92
	4.00
Givisiez d/p Murten	45.92
Belfaux CFF	44.45
	4.33
Grolley	40.12
Léchelles Tanklager (embr)	38.03
Léchelles	35.48
	3.71
Cousset	31.77
Bossy Moulins (embr)	31.04
Bossy Bois (embr)	29.99
Corcélles-Sud	29.73
	1.84
d/p Lyss	
Payerne	27.89
d/p Lausanne	
	4.21
Cugy FR	23.68
	3.65
Sévaz (embr)	20.03
Siporex (embr)	19.47
Estavayer-le-Lac	18.07
	5.45
Cheyres	12.62
	3.81
Yvonand	8.81
	7.03
Yverdon-Champ Pittet	1.78
Yverdon-les-Bains	0.00
	39.13

d/p Lausanne

Yverdon-les-Bains

d/p Neuchâtel

d/p Lausanne

Fribourg

d/p Bern

Fribourg

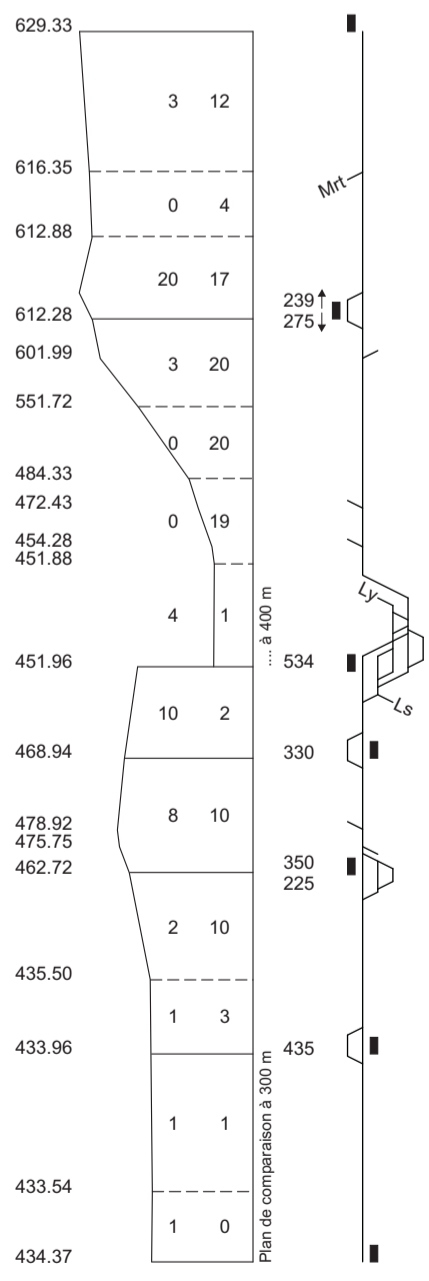

Altitude au dessus de la mer, RPN = 373.60
Profil en long
Pente maximum
Rampe maximum
Situation des stations, bifurcations, plus longues voies d'évitement

d/p Lausanne

Yverdon-les-Bains

d/p Neuchâtel

	49.92
	4.00
Givisiez d/p Murten	45.92
Belfaux CFF	44.45
	4.33
Grolley	40.12
Léchelles Tanklager (embr)	38.03
Léchelles	35.48
	3.71
Cousset	31.77
Bossy Moulins (embr)	31.04
Bossy Bois (embr)	29.99
Corcélles-Sud	29.73
	1.84
d/p Lyss	
Payerne	27.89
d/p Lausanne	
	4.21
Cugy FR	23.68
	3.65
Sévaz (embr)	20.03
Siporex (embr)	19.47
Estavayer-le-Lac	18.07
	5.45
Cheyres	12.62
	3.81
Yvonand	8.81
	7.03
Yverdon-Champ Pittet	1.78
Yverdon-les-Bains	0.00
	39.13

Altitude au dessus
de la mer
RPN = 373.60

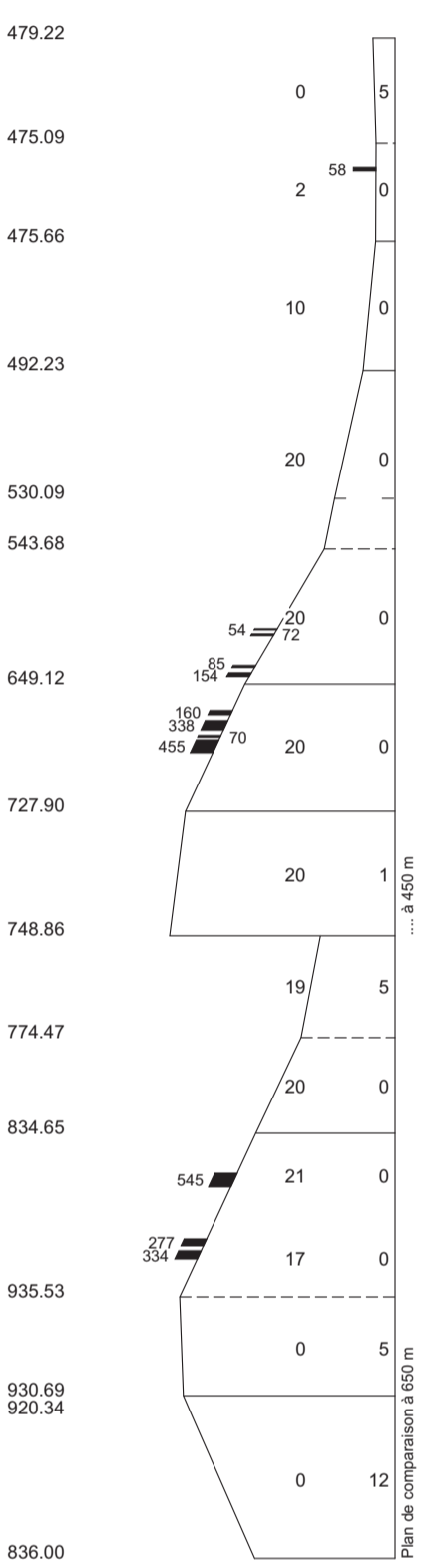

Profil en long
Pente maximum
Rampe maximum

Situation des
stations, bifur-
cations, plus
longues voies
d'évitement

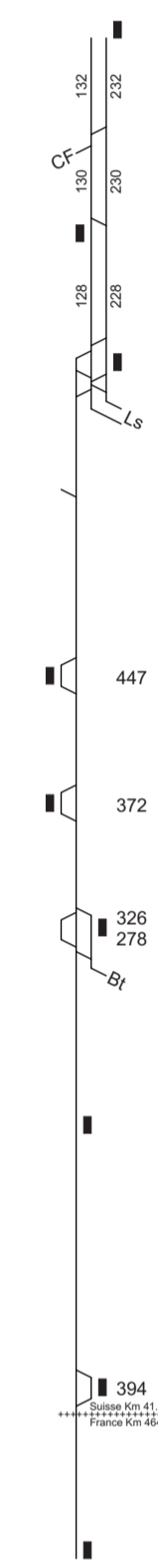

Stations de block

Station	Distance de stat. à stat.	Kilométrage de la voie
Bern		
Kerzers		
Ins		
Neuchâtel		
d/p Biel/Bienne		
Neuchâtel		
Neuchâtel	75.29	
Neuchâtel-Vauseyon (bif)	1.34	
d/p La Chaux-de-Fonds	73.96	
Neuchâtel-Serrières	1.57	
	72.39	
Auvernier	2.05	
d/p Lausanne	70.34	4.98
Cottardart (embr)	2.71	
Bôle	7.69	
	0.61	8.30
Champ-du-Moulin	5.35	
	13.65	
Noiraigue	4.46	
	18.11	
Travers	4.34	
d/p Buttes	22.45	
Couvet CFF	3.60	
Boveresse	26.04	
	3.43	
Les Bayards	29.47	
	6.43	
Les Verrières	35.90	
Les Verrières-Frontière	3.46	
	39.36	41.07
Pontarlier	12.99	
	52.35	
	SNCF 453.56	
Ste-Colombe (Doubs)		
La Rivière		
d/p Vallorbe		
Frasne		
Neuchâtel faisceau D		
Neuchâtel		
	75.29	
Neuchâtel-Vauseyon (bif)	1.34	
d/p Lausanne/Travers	73.96	1.37
Neuchâtel-Vauseyon	0.27	1.64
Les Deurres	1.46	3.10
Corcelles-Peseux	1.22	4.32
	6.08	
Chambrelieu	3.66	10.40
Montmollin-Montezillon	2.84	14.06
Les Geneveys-sur-Coffrane	4.09	16.90
	4.09	
Les Hauts-Geneveys	8.51	20.99
	8.51	
d/p Sonceboz		
La Chaux-de-Fonds	29.49	
d/p Saig ↙ d/p PdM ↘	1.15	
La Chaux-de-Fonds-Ouest	1.54	30.64
Les Eplatures	1.22	32.18
Le Crêt-du-Loclé	3.67	33.40
	3.67	
Le Locle	37.07	
d/p Les Brenets	1.79	
Le Locle-Col-des-Roches	38.86	
Le Locle-Frontière	SNCF 481.737	
Morteau		

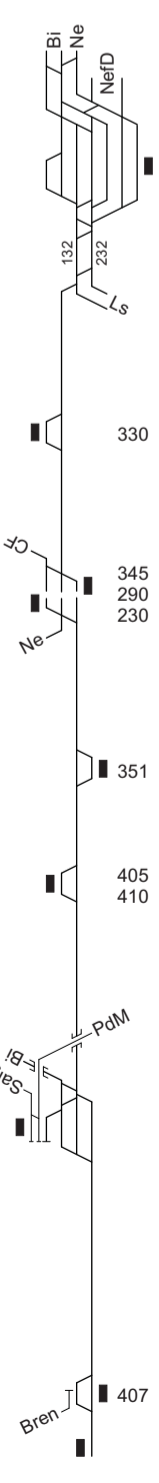
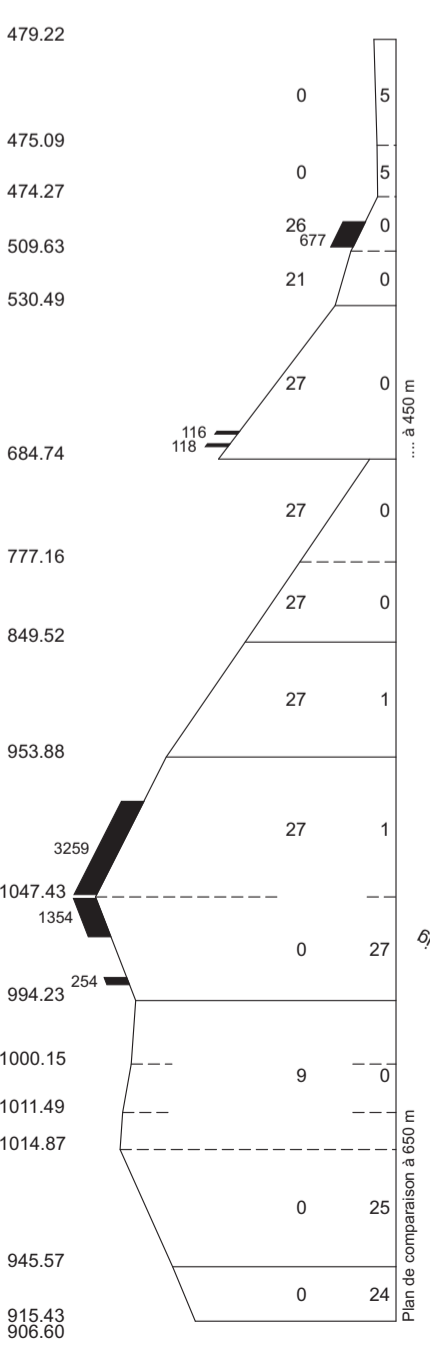

Stations de block

Station	Distance de stat. à stat.	Kilométrage de la voie
Ste-Colombe (Doubs)		
La Rivière		
d/p Vallorbe		
Frasne		
Neuchâtel faisceau D		
Neuchâtel		
	75.29	
Neuchâtel-Vauseyon (bif)	1.34	
d/p Lausanne/Travers	73.96	1.37
Neuchâtel-Vauseyon	0.27	1.64
Les Deurres	1.46	3.10
Corcelles-Peseux	1.22	4.32
	6.08	
Chambrelieu	3.66	10.40
Montmollin-Montezillon	2.84	14.06
Les Geneveys-sur-Coffrane	4.09	16.90
	4.09	
Les Hauts-Geneveys	8.51	20.99
	8.51	
d/p Sonceboz		
La Chaux-de-Fonds	29.49	
d/p Saig ↙ d/p PdM ↘	1.15	
La Chaux-de-Fonds-Ouest	1.54	30.64
Les Eplatures	1.22	32.18
Le Crêt-du-Loclé	3.67	33.40
	3.67	
Le Locle	37.07	
d/p Les Brenets	1.79	
Le Locle-Col-des-Roches	38.86	
Le Locle-Frontière	SNCF 481.737	
Morteau		

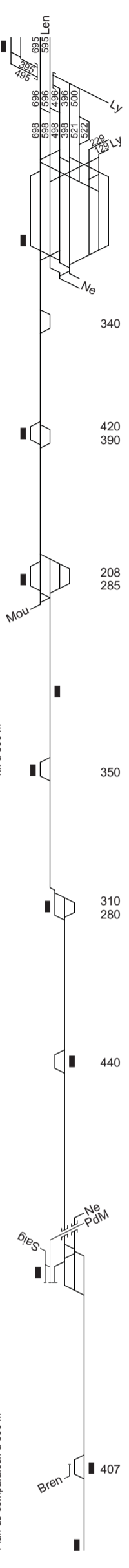
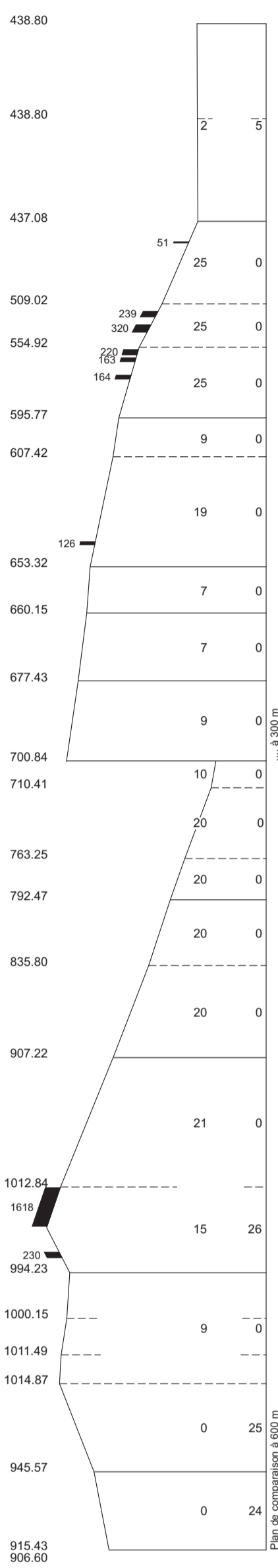

Altitude au dessus de la mer RPN = 373.60
Profil en long
Pente maximum
Rampe maximum

Situation des stations, bifurcations, plus longues voies d'évitement

Stations de block
d/p Biel/Bienne

Distance de stat. à stat.
Kilométrage de la voie

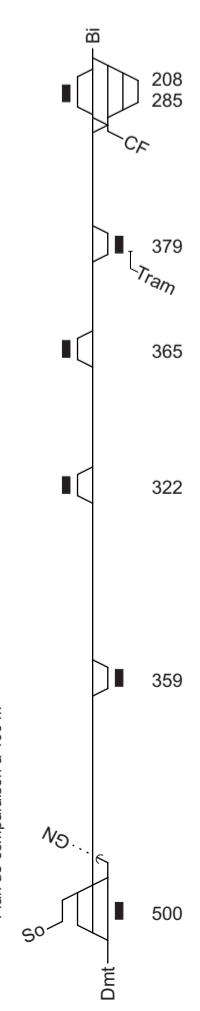
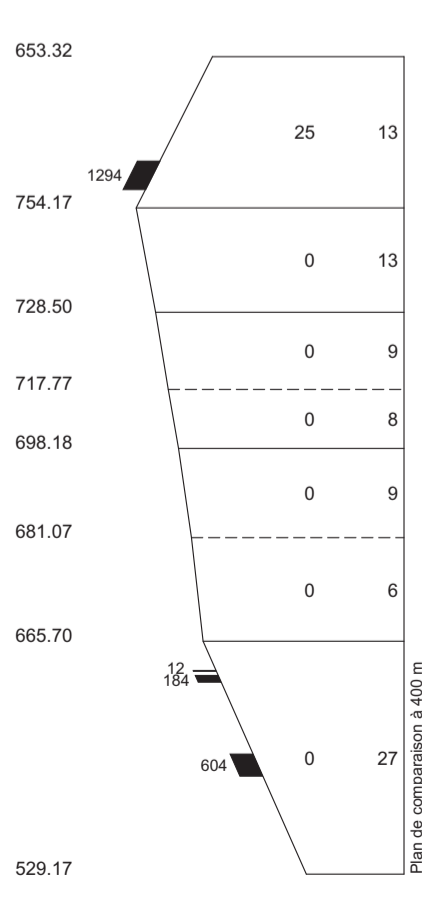

Stations de block
d/p Biel/Bienne

Distance de stat. à stat.
Kilométrage de la voie

v/n Bern

Biel/Bienne

v/n Lengnau

Biel RB	96.60
Biel RB West	97.36
Biel/Bienne d/p Neuchâtel	99.37 33.83
Mahlenwald	37.27
Frinvillier-Taubenloch	39.11
Reuchenette-Péry	42.04
La Heutte	43.68
Sonceboz-Sombeval d/p Moutier	48.28
Corgémont	50.22
Cortébert	53.12
Courtelay	56.47
Cormoret	57.64
Villeret	60.63
St-Imier	62.38
Sonvilier	65.16 65.17
Renan BE	69.02
d/p Neuchâtel	
La Chaux-de-Fonds d/p Saig / d/p PdM	77.83 29.49
La Chaux-de-Fonds-Ouest	30.64
Les Eplatures	32.18
Le Crêt-du-Loche	33.40
Le Locle d/p Les Brenets	37.07
Le Locle-Col-des-Roches Le Locle-Frontière	38.86 SNCF 481.737

Morteau

Sonceboz-Sombeval d/p La Chaux-de-Fonds	48.28
Tavannes d/p Tramelan	55.17
Reconvilier	58.02
Pontenet	60.12
Malleray-Bévilard	61.79
Sorvilier	64.20
Court	67.04
d/p Grenchen Nord	
Moutier d/p Solothurn	73.40
d/p Delémont	

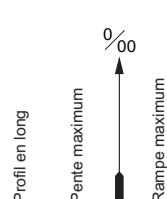

Situation des
stations, bifur-
cations, plus
longues voies
d'évitement

Stations de block
v/n Neuchâtel
v/n Sonceboz
Biel/Bienne

Distance de
stat. à stat.

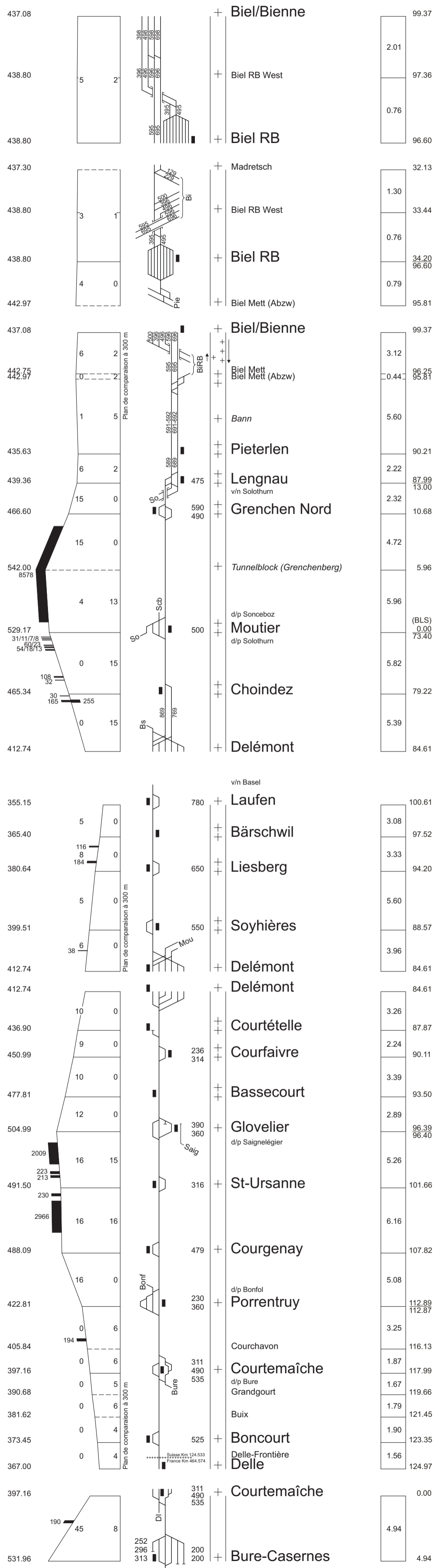

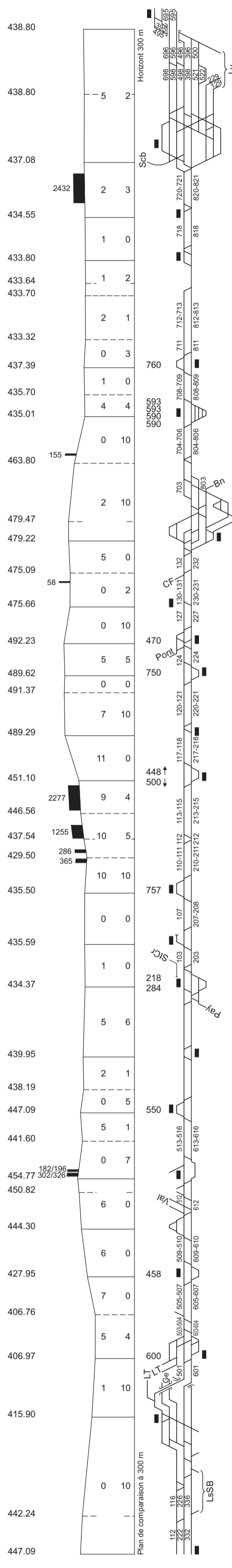

Altitude au dessus de la mer RPN = 373.60

Profil en long

Rampe maximum
Pente maximum

Situation des stations, bifurcations, plus longues voies d'évitement

Neuchâtel-Mail	76.14
Neuchâtel faisceau D	75.58
Neuchâtel	75.29
d/p Lengnau	
Biel/Bienne	
Biel RB	96.60
Biel RB West	97.36
Biel/Bienne d/p Sonceboz	99.37 104.50
Vingelz	4.55
Tüscherz	99.95
Twann	95.98
Ligerz	1.97
Chavannes	0.27
Poudeille	3.68
La Neuveville	90.05
Le Landeron	87.72
Cressier NE	2.17
Cornaux	85.55
Souaillon	1.95
St-Blaise CFF	4.23
La Coudre	79.37
Neuchâtel-Mail	76.14
Neuchâtel	75.29
Neuchâtel-Vauseyon (bif) d/p La Chaux-de-Fonds	1.34 73.96
Neuchâtel-Serrières	72.39
Auvernier d/p Pontarlier/Buttes	2.05 70.34
Colombier	67.67
Boudry	1.42
Perreux	3.97
Bevaix	62.28
Chassagne	4.18
Gorgier-St-Aubin	58.10 57.89
Vaumarcus	3.04
La Lance (diag é)	2.41
Concise	1.69
Onnens-Bonvillars	50.75
Grandson	3.27
d/p Ste-Croix	4.77
Yverdon-les-Bains	42.71
d/p Payerne	3.58
Champs-Lovats	39.13
Ependes	6.43
Essert-Pittet d/p Orbe	32.70 3.03
Chavornay	29.67
Bavois	2.22
Bavois	27.46
Eclépens	25.8
Eclépens sud	3.50
d/p Vallorbe	21.38 0.79
Daillens	20.59
Vaux	2.18
Cossonay	18.41
Gollion	3.92
Vufflens-la-Ville	14.49
Faillen	3.51
Bussigny	10.97
d/p Lausanne-Triage	4.05
d/p Genève	6.93
Renens VD	2.42
Malley	4.51
Lausanne (bif)	3.38
Lausanne d/p Palézieux	1.13 0.00

Stations de block

d/p Vevey

voie N2
voie A9/B9

Distance de stat. à stat.

Kilométrage de la voie

voie L7

voie A9/B9

voie L7

voie L7

voie A9/B9

voie L7

Höhen über Meer
RPN = 373.60

Längenprofil

Grösstes Gefälle

Grösste Steigung

Stationenlage

Abzweigungen

Längste Ausweichgleise

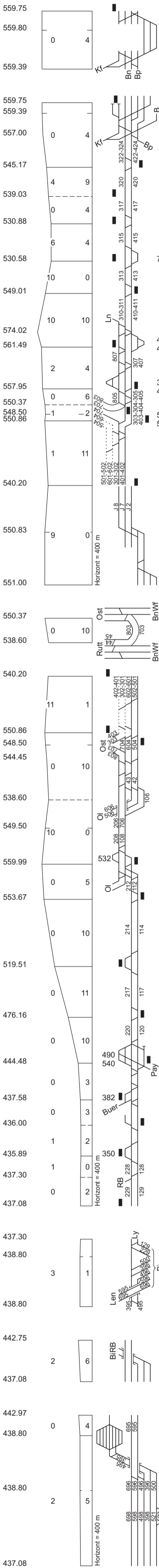

Blockstationen

v/n Neuchâtel

Entf. von Stat. zu Stat.

Kilometrierung der Bahn

v/n Spiez

Thun Schadau (Abzw)			
Thun			137.02
Thun Gruppe B	0.29		136.73
	0.58		
Thun (Abzw)			136.15
Thun			137.02
Thun (Abzw)	0.87		136.15
Lerchenfeld	1.52		134.63
Allmend			
Uttigen	3.53		131.10
Kiesen	2.79		128.30
Wichtrach	2.57		125.73
Münsingen	3.60		122.13
Rubigen	3.09		119.04
Allmendingen	3.67		115.37
v/n Langnau			
Gümligen Süd (Abzw)	1.41		113.96
Gümligen			
Dennigkofen	3.19		110.77
Ostermundigen			
Wankdorf (Abzw)	1.28		109.48
Bern Wankdorf	0.51		108.97
Bern Wylerfeld	0.39		108.58
			103.33
		Gl. 300 / 400	2.80
Lorraine			
Bern			106.16
			97.10
Bern JKLM	0.78		96.32
Bern Weyermannshaus	1.32		95.00
Wankdorf (Abzw)			103.17
Löchligut Süd (Abzw)	0.67		102.50
Löchligut	1.22		101.28
Bern			106.16
Lorraine		Gl. 500 / 600	2.83
Bern Wylerfeld			
Bern Wankdorf	0.38		103.33
Löchligut Süd (Abzw)	0.45		102.95
			102.50
Löchligut	1.22		101.28
v/n Olten			
Rütti (Abzw)	1.06		100.22
			100.20
Zollikofen	1.40		98.81
v/n Olten			(7.46)
Münchenbuchsee	2.66		10.12
Schüpfen	5.57		15.69
Suberg-Grossaffoltern	4.23		19.92
Lyss	3.44		23.37
v/n Payeme			
Busswil	2.79		26.16
v/n Büren a. d. Aare			
v/n Studen Auto	1.96		28.12
Studen BE			
Brügg BE	2.39		30.51
Madretsch	1.62		32.13
v/n Biel RB			33.07
Biel/Bienne	1.46		98.84
			99.37
Madretsch			32.13
Biel RB West	1.30		33.44
			97.36
Biel RB	0.76		96.60
Biel Mett			96.25
Biel/Bienne	3.12		99.37
Biel Mett (Abzw)			95.81
Biel RB	0.79		96.60
Biel RB West	0.76		97.36
Biel/Bienne	2.01		99.37

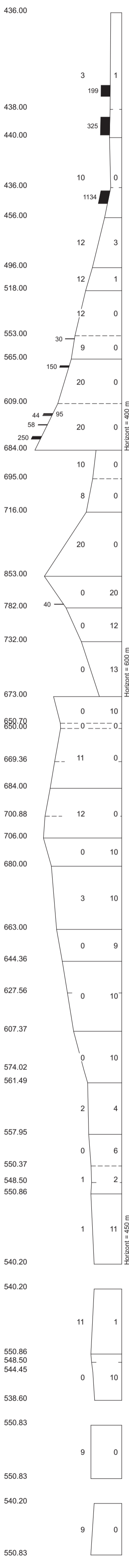
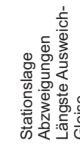
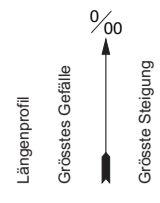

Blockstationen	Entf. von Stat. zu Stat.	Kilometrierung der Bahn
Luzern	1.73	95.09
Heimbach (Spw)	0.51	93.36
Gütsch (Abzw)	1.02	92.85
Fluhmühle (Abzw)	2.66	91.82
Littau	6.06	89.18
Malters	2.98	83.12
Schachen LU	3.99	80.14
Werthenstein	1.79	76.15
Wolhusen v/n Langenthal	3.89	74.36 74.35
Doppleschwand-Romoos	4.10	70.46
Entlebuch	2.22	66.37
Hasle LU	4.07	64.15
Schüpfheim	7.87	60.07
Escholzmatt	3.92	52.19
Wiggen	5.13	48.27
Trubschachen	5.66	43.13
Langnau	2.73	37.47
Obermatt Emmenmatt v/n Burgdorf	2.09	34.73 34.09
Schüpbach (Signau)	1.63	32.00
Signau	1.72	30.37
Schlossberg (Signau)	1.37	28.65
Bowil	2.94	27.27 27.28
Zäziwil	3.82	24.34
Konolfingen v/n Thun	3.30	20.52
Tägertschi	1.92	17.22
Bachtele (Trimstein)	2.31	15.30
Worb SBB	3.89	12.99
Gümligen Süd (Abzw) v/n Thun	1.41	9.10 115.37 113.96
Dennigkofen	3.19	
Ostermündigen	1.28	110.77
Wankdorf (Abzw)	0.51	109.48
Bern Wankdorf Bern Wylerfeld	0.39	108.97 108.58 103.33
Lorraine	2.80	GI. 300 / 400
Bern		106.16
Bern	2.80	GI. 500 / 600
Bern Wylerfeld Bern Wankdorf Löchligut Süd (Abzw)	0.38 0.45	103.33 102.95 102.50
Löchligut	1.22	101.28
Bern JKLM	1.32	96.32
Bn Weyermannshaus		95.00
Bern	0.86	97.18
Bern JKLM		96.32

v/n Brüning

Höhen über Meer
RPN = 373.60

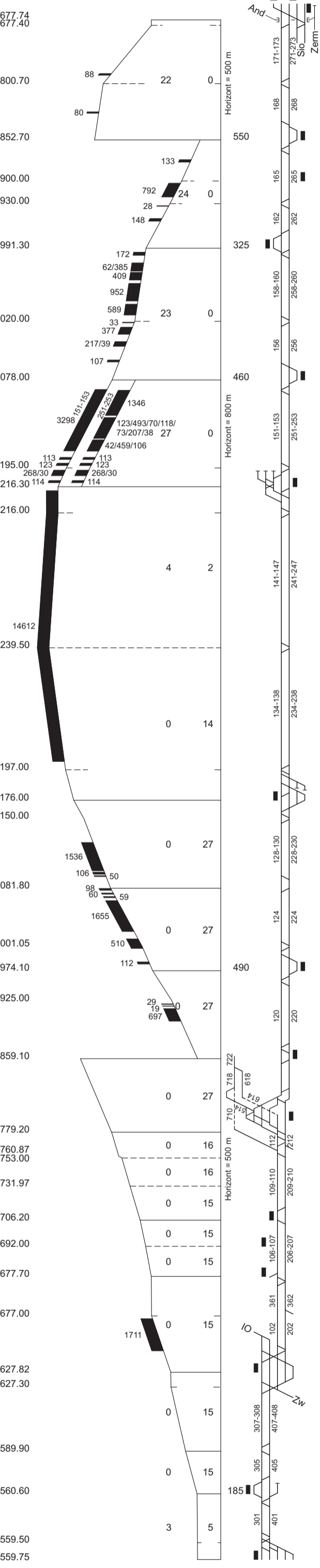

v/n Domodossola

Brig Tunnel
Brig
Brig-Lötschberg (Abzw)

Gamsen SBB

v/n Sion

Brig Tunnel
Brig RB

Brig-Lötschberg (Abzw)

Entf. von Stat. zu Stat.

Kilometrierung der Bahn

Brig Brig-Lötschberg (Abzw)	0.30	73.81
	3.16	73.51
Mundbach (Spw)		70.35
	3.06	
Lalden		67.29
	2.29	
Eggerberg		64.99
Viktoria (Spw)	1.30	63.70
	2.43	
Ausserberg		61.27
		61.28
	3.98	
Rarnerkumme (Spw)		57.30
	3.11	
Hohtenn		54.19
	4.73	
Stockgraben (Spw)		49.46
Goppenstein	1.02	48.44
Goppenstein Lötschberg (Spw)	1.41	47.03
	7.27	
Tunnelstation Lötschberg (Spw)		39.76
	6.51	
Eggenschwand (Spw)		33.26
	1.69	
Kandersteg		31.57
Bühl (Spw)	1.07	30.50
	3.72	
Felsenburg		26.78
	3.11	
Fürten (Spw)		23.68
Blausee-Mitholz	1.33	22.35
Grubi (Spw)	1.70	20.65
	3.20	
Kandergrund		17.45
	3.92	
Frutigen		13.54
Winklen (Spw)	1.51	12.03
Wengi (AnG)	-0.16	11.87
	1.59	
Wengi-Ey (Abzw)		10.28
	1.93	9.97
Reichenbach im Kandertal		9.97
		8.29
Mülenen	1.44	6.85
Heustrich-Emdthal	1.68	5.16
	2.17	
Hondrich Süd (AnG)		2.99
		2.90
	3.00	0.00
Spiez		-0.106
Spiez (Abzw)	0.89	9.78
		8.90
	3.46	
Einigen		5.44
	2.33	
Gwatt		3.10
	2.62	
Thun Schadau (Abzw)		0.49
Thun	0.06	137.02
	137.59	

Wichtiger Hinweis:
Um die Abwechslung des Fahrplans zu erhöhen,
wurde auf die Darstellung der Verkehrs-
perioden (VP) bei den Zügen der Serie
28000-28999 verzichtet.

Thun

Thun Gruppe B

Thun (Abzw)

Thun

Thun (Abzw)

v/n Bern

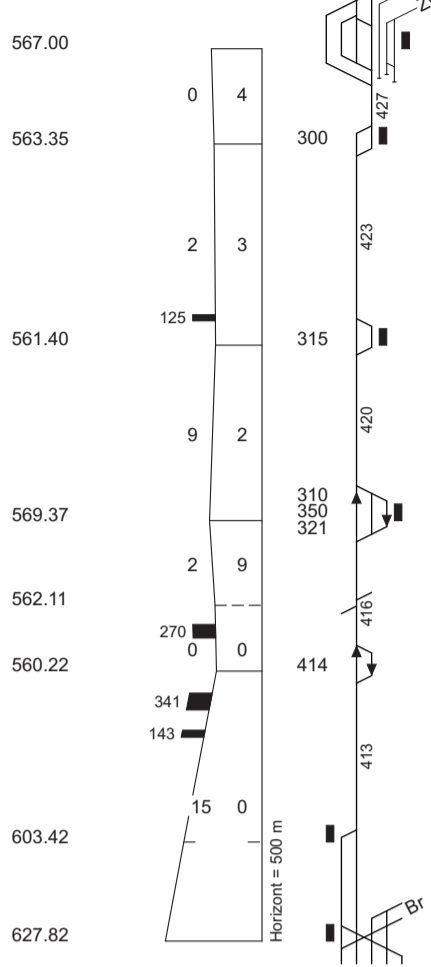

+	Interlaken Ost	27.95
+	Interlaken West	1.93
+		26.02
+		4.01
+	Därligen	22.02
+		3.52
+	Leissigen	18.50
+		18.49
+	Leissigbad (Agl)	1.79
+	Krattighalde	1.30
+		15.40
+		3.44
+	Faulensee	11.96
+		11.88
+	Spiez	2.02
+		9.78

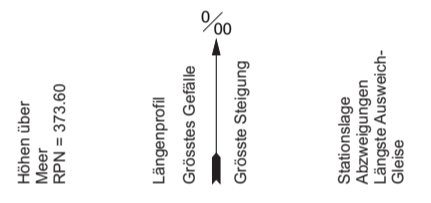

v/n Meiringen

v/n Zweilütschinen

Interlaken Ost

v/n Brig

Spiez

Spiez (Abzw)

v/n Thun

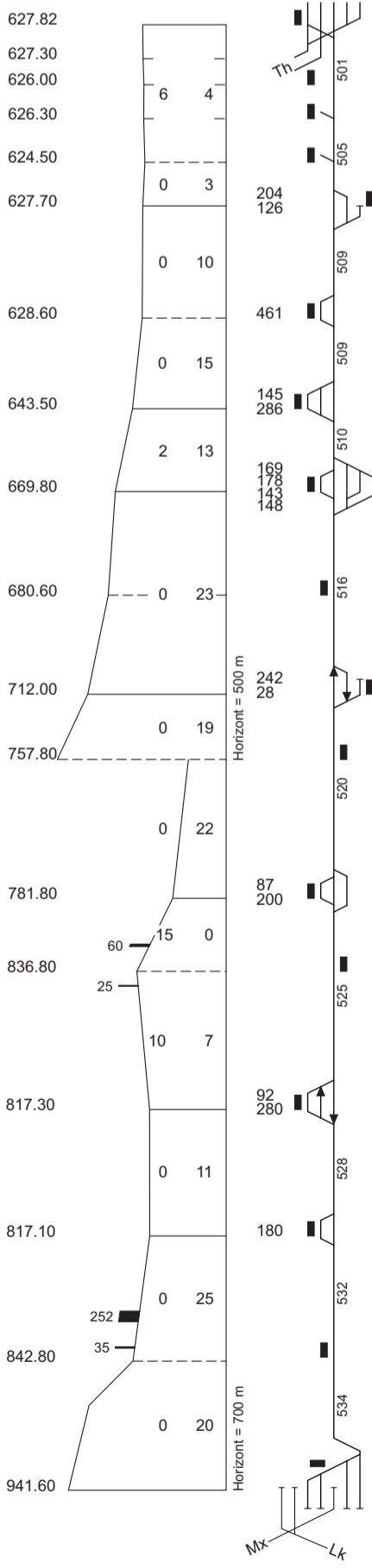

+	Spiez	0.00
+	Spiez (Abzw)	0.89
+	Spiezmoos Süd	0.69
+	Lattigen bei Spiez	0.88
+	Eifeld	1.04
+	Wimmis	1.05
+		2.61
+	Burgholz	7.16
+		2.18
+	Oey-Diemtigen	9.33
+		1.96
+	Erlenbach im Simmental	11.29
+		2.50
+	Ringoldingen	13.79
+		2.31
+	Därstetten	16.10
+	Weissenburg	1.54
+		17.64
+		3.25
+	Oberwil im Simmental	20.90
+		1.73
+	Enge im Simmental	22.63
+		3.28
+	Boltigen	25.90
+		2.98
+	Weissenbach	28.89
+		2.94
+	Grubenwald	31.82
+		3.08
+	Zweisimmen	34.90

Zweisimmen

v/n Lenk

v/n Gstaad

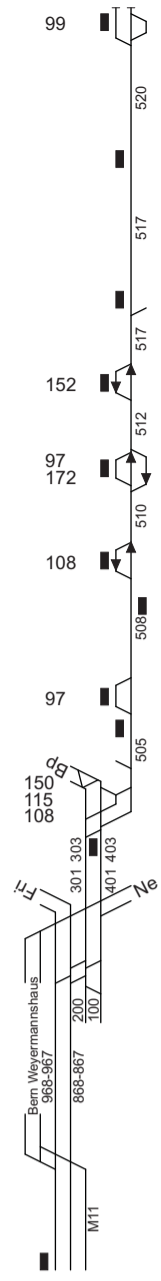
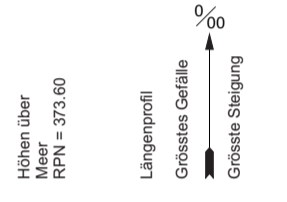
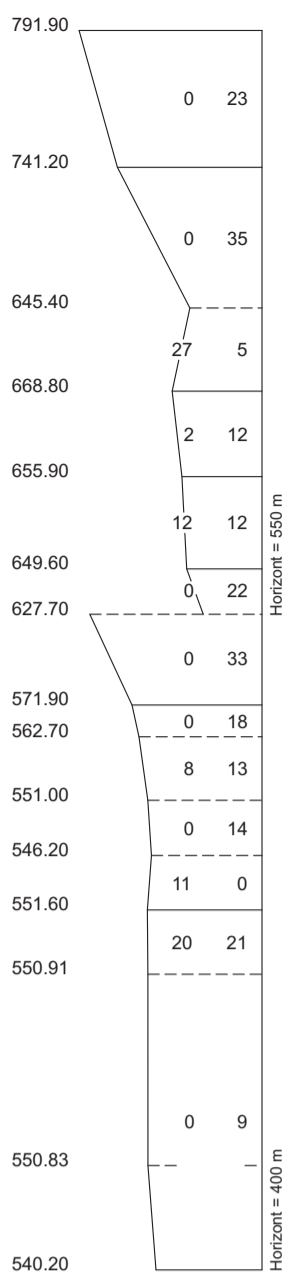

Station	Entf. von Stat. zu Stat.	Kilometerierung der Bahn
Schwarzenburg	3.04	20.87
Lanzenhäusern	3.18	17.83
Schwarzwasserbrücke	1.83	14.66
Mittelhäusern	1.94	12.82
Niederscherli	2.01	10.89
Gasel	1.08	8.87
Moos	2.08	7.80
Köniz	0.72	5.71
Liebefeld	1.47	5.00
Bern Fischermätteli (Abzw)	0.40	3.52
Bern Ausserholligen GBS	0.41	3.12
Bern Holligen	0.48	2.71
Bern Weyermannshaus (Spw)	1.41	2.23 / 94.92
Bern JKLM	0.86	96.32
Bern		97.18

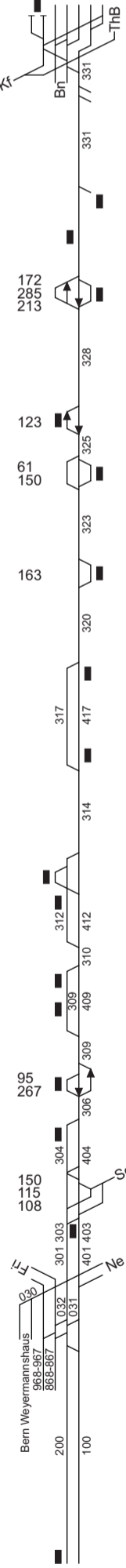
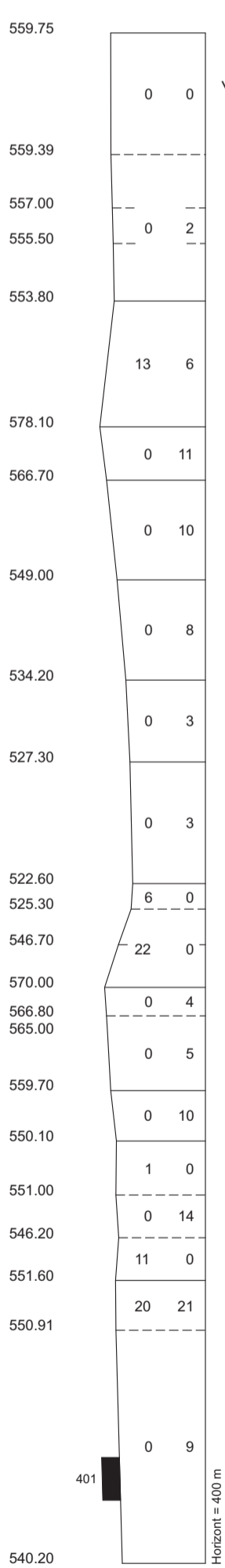

Station	Entf. von Stat. zu Stat.	Kilometerierung der Bahn
Thun	0.87	34.48
Thun (Abzw)	1.53	33.61
Lerchenfeld	1.08	32.08
Uetendorf Allmend	1.70	30.99
Uetendorf	3.58	29.30
Seftigen	1.52	25.72
Burgstein-Wattenwil	2.86	24.20
Thurnen	2.88	21.34
Kaufdorf	2.34	18.47
Toffen	3.43	16.13
Belp	0.78	12.70
Belp Steinbach	1.05	11.92
Falkenhaus (Spw)	1.21	10.87
Kehrsatz	0.89	9.67
Kehrsatz Nord	0.51	8.77
Breitenacker (Spw)	1.70	8.27
Wabern bei Bern	1.48	6.57
Bern Weissenbühl	1.57	5.09
Bern Fischermätteli (Abzw)	0.40	3.52
Bern Ausserholligen GBS	0.41	3.12
Bern Holligen	0.48	2.71
Bern Weyermannshaus (Spw)	2.18	2.23
Bern JKLM	0.86	96.32
Bern		97.18

Station	Entf. von Stat. zu Stat.	Kilometerierung der Bahn
Bern Holligen	0.41	2.71
Bern Steigerhubel (Abzw)	0.48	2.23
Bern Weyermannshaus	2.18	2.23
Bern JKLM	0.86	96.32
Bern		97.18

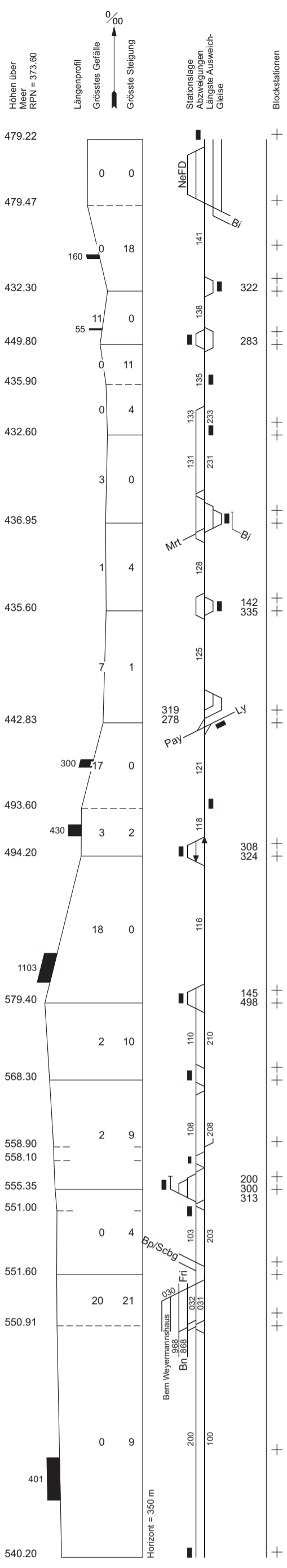

Neuchâtel

Neuchâtel faisceau D

Neuchâtel-Mail

Neuchâtel

Neuchâtel-Mail

St-Blaise-Lac

Marin-Epagnier

Zihlbrücke

Fanelwald

Gampelen

Ins

v/n Murten

Müntschemier

v/n Lyss

Kerzers

v/n Payerne

Ferenbalm-Gurbrü

Gümmenen

Rosshäusern

Riedbach

Niederbottigen (AGI)

Bern Brünnen

Bern Bümpliz Nord

Bern Stöckacker

Bern Holligen

Bern Weyermannshaus (Spw)

Gl. 100 / 200

Bern

Entf. von Stat. zu Stat.	Kilometrierung der Bahn
0.85	75.29
3.29	76.14 42.03
2.02	38.74
1.54	36.72
0.98	35.18
1.08	34.20
3.34	33.12
3.35	29.78
4.29	26.44
3.29	22.14
1.85	18.85
5.55	17.00
2.95	11.45
2.60	8.49
0.57	5.89
1.14	5.32
0.87	4.18
0.60	3.31
0.48	2.71
2.18	2.23
	0.60

Bern Holligen

Bern Weyermannshaus (Spw)

Gleise 967 / 867

Bern JKLM

Gleise P (J2,J7,J8)

Bern

Bern Holligen

Bern Steigerhubel (Abzw)

Bern Weyermannshaus

Bern JKLM

Gleise G (J1, M11)

Bern

39 A

Höhen über Meer RPN = 373.60

Längenprofil Grösstes Gefälle Grösste Steigung

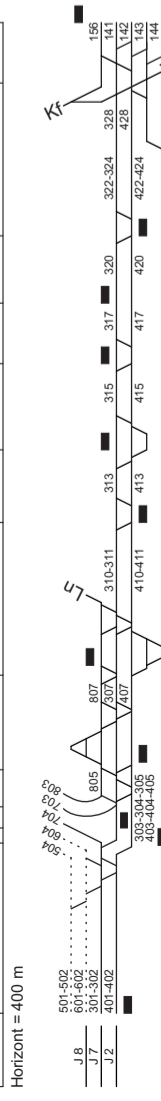
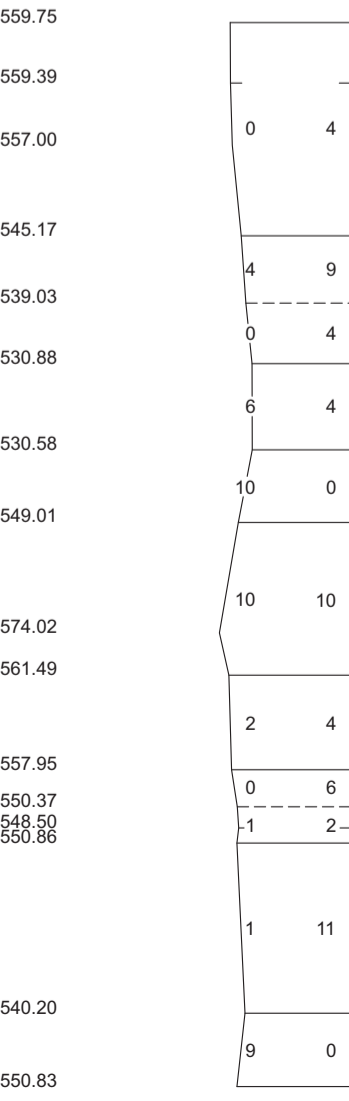
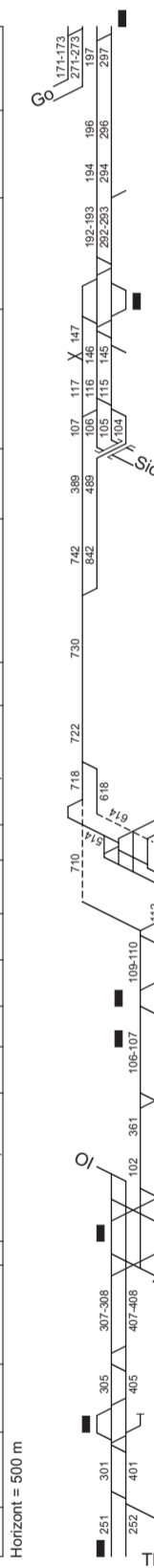
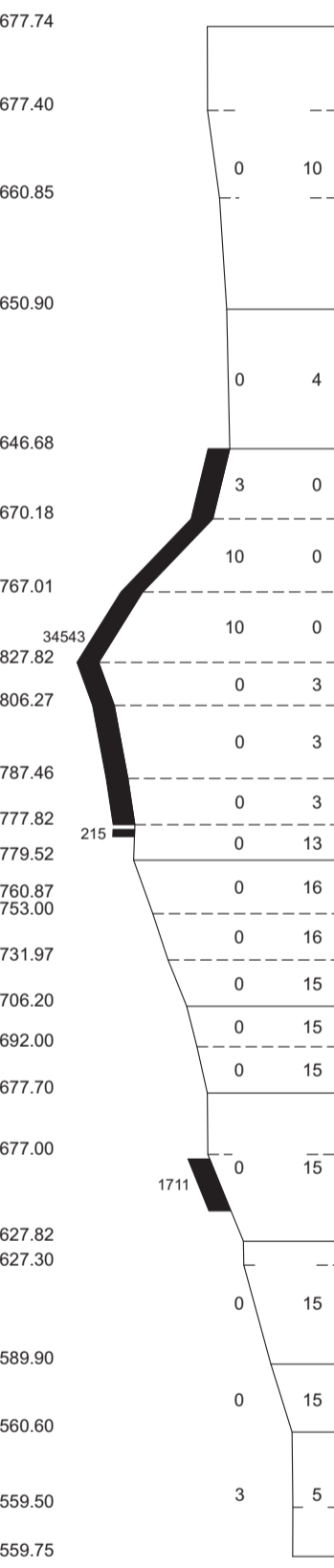
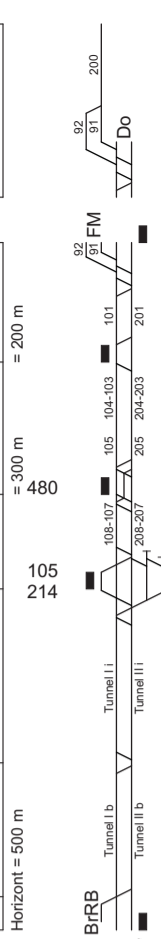
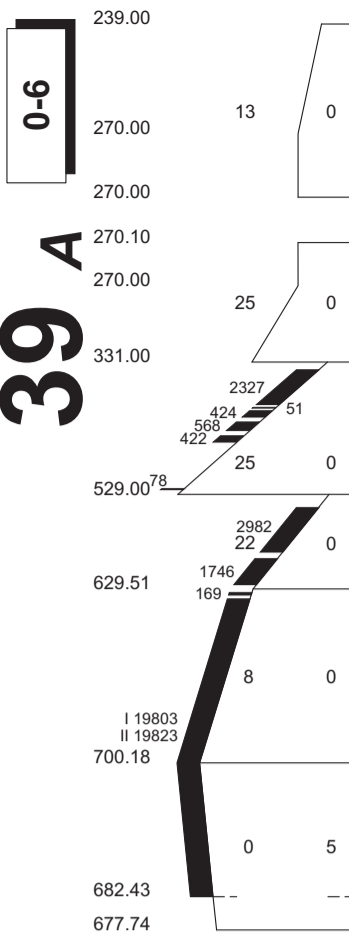
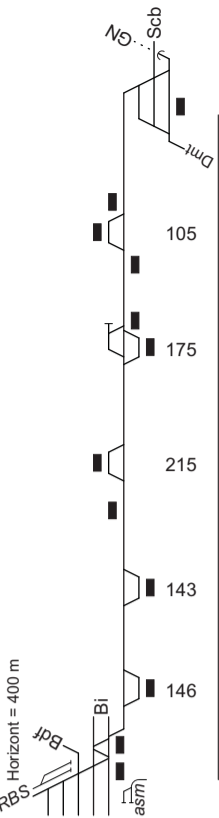
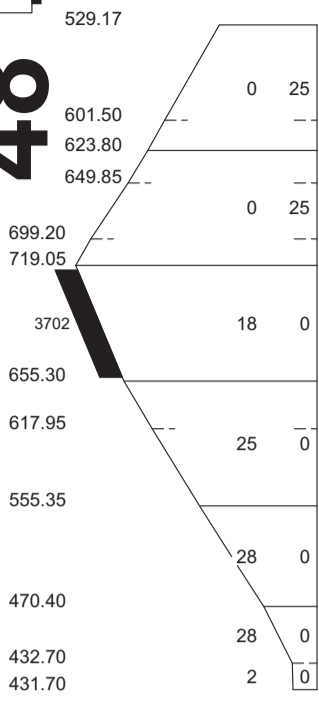

Table of station names and distances, including Domodossola II, Domodossola FM, Preglia, Varzo, Iselle di Trasquera, Staz. della Galleria Sempione, Brig Tunnel, Brig RB, Brig Lötschberg (Abzw), Brig, Brig Lötschberg (Abzw), Brig, Brig Lötschberg (Abzw), Gamsen SBB, Visp, St. German (Abzw), Lötschen, Ferden (Spw), Mitholz, Adelrain (Abzw), Frutigen Nordportal (Abzw), Frutigen, Winklen (Spw), Wengi (AGI), Wengi-Ey (Abzw), Reichenbach i/K., Mülenen, Heustrich-Emdthal, Hondrich Süd (AGI), Spiez, Spiez (Abzw), Einigen, Gwatt, Thun Schadau (Abzw), Thun, Thun, Thun (Abzw), Lerchenfeld, Allmend, Uttigen, Kiesen, Wichtrach, Münsingen, Rubigen, Allmendingen, Gümligen Süd (Abzw), Gümligen, Dennigkofen, Ostermundigen, Wankdorf (Abzw), Bern Wankdorf, Bern Wylerfeld, Lorraine, Bern, and Bern JKLM.



v.u.n. Delémont

Moutier	22.09	23.05
Grandval	18.84	19.80
Crémines	17.77	18.74
Corcelles BE	16.58	17.54
Crémines-Zoo	14.60	15.56
Gänsbrunnen	13.62	14.58
Oberdorf SO	9.63	10.59
Im Holz	8.02	8.98
Lommiswil	5.34	6.30
Langendorf	1.91	2.87
Solothurn West	0.00	0.96
Solothurn	0.00	0.00

v.u.n. Olten

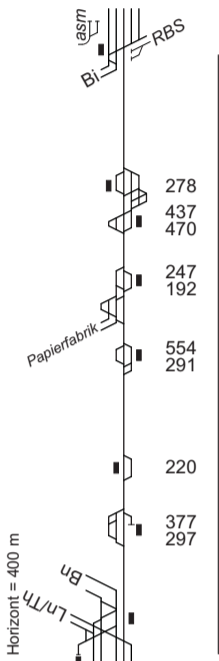
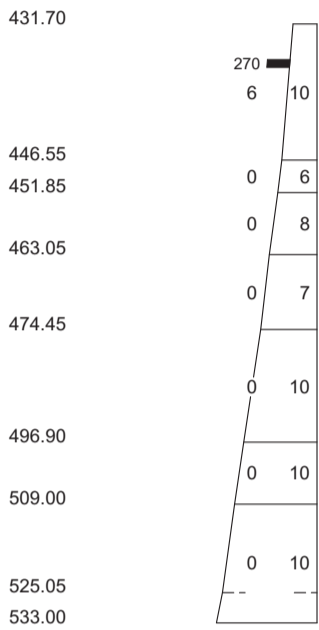

Solothurn		0.00
Biberist RM	4.69	4.69
Gerlafingen	1.16	5.85
Wiler	2.17	8.02
Utzenstorf	2.56	10.58
Aefligen	3.86	14.44
Kirchberg-Alchenflüh	2.19	16.63
Burgdorf Buchmatt	3.04	19.67
Burgdorf	1.07	20.74

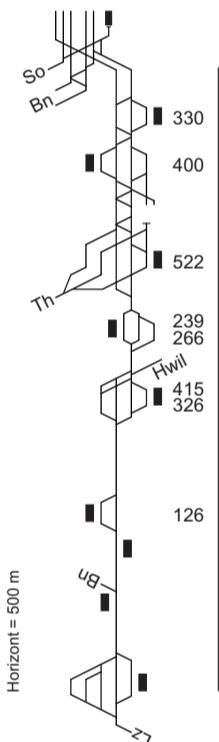
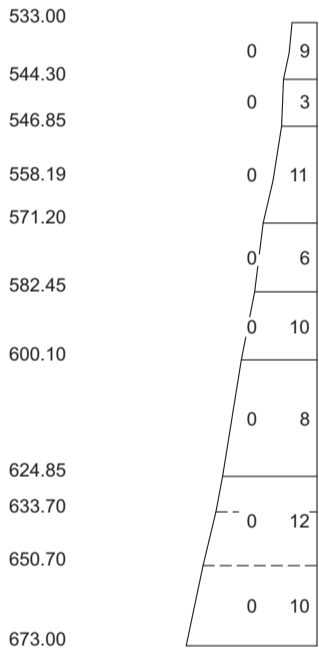

Burgdorf	20.74	0.00
Burgdorf Steinhof	22.64	1.90
Oberburg	24.30	3.56
Schachen	3.37	
Hasle-Rüegsau	27.67	6.93
Lützelflüh-Goldbach	30.05	9.31
Ramsei	32.41	11.67
Zollbrück	36.38	15.64
Neumühle	37.63	16.89
Obermatt	39.46	18.72
Langnau	42.21	21.47

v.u.n. Luzern

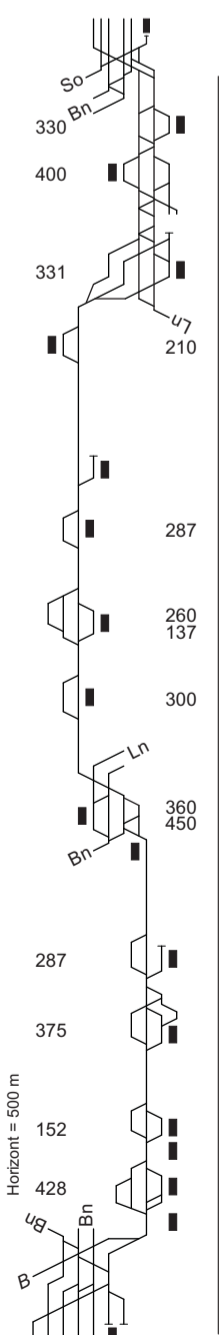
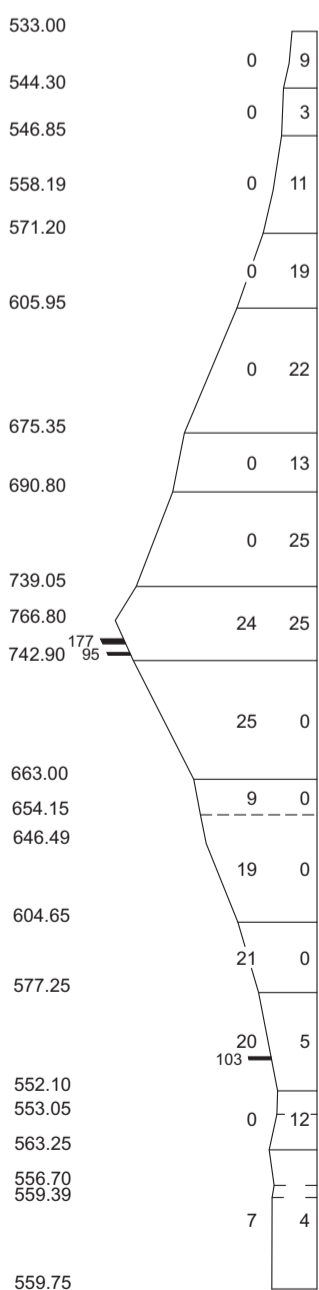

Burgdorf		0.00
Burgdorf Steinhof	1.90	1.90
Oberburg	1.66	3.56
Schachen	3.37	
Hasle-Rüegsau	0.00	6.93
v/n Langnau	2.56	
Schafhausen i/E	2.56	9.49
Bigenthal	6.83	13.76
Walkringen	8.89	15.82
Biglen	12.09	19.02
Grosshöchstetten	14.67	21.60
v/n Langnau	4.07	
Konolfingen	18.74	25.67
v/n Bern	19.96	26.89
Stalden i/E	3.69	
Dessigkofen	23.65	30.58
Oberdiessbach	26.08	33.01
Brenzikofen	3.30	
Heimberg	29.38	36.31
Lädeli	30.25	37.18
Steffisburg	31.51	38.44
Schwäbis Thun (Abzw)	32.73	39.66
Thun	32.95	39.88
Thun (Abzw)	0.87	
Thun	33.82	40.75

Höhen über Meer
RPN = 373.60

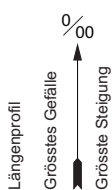

Stationslage
Abzweigungen
Längste Ausweich-
Gleise

Blockstationen

Thun (Abzw)

Thun

Thun Schadau (Abzw)

Entf. von Stat. zu Stat.

Kilometrierung der Bahn

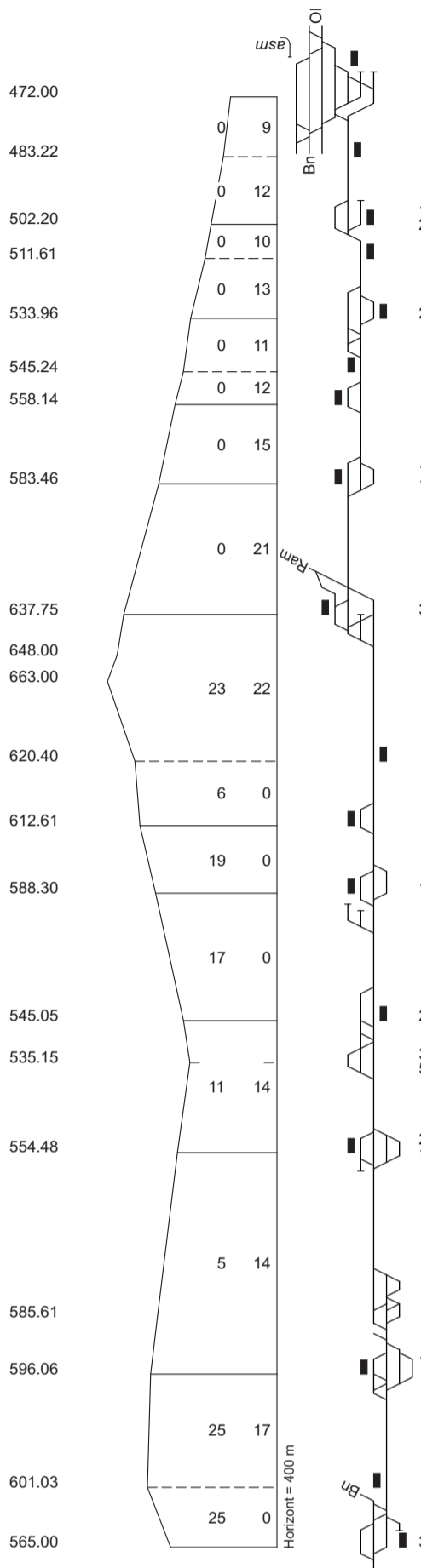

v.u.n. Olten
v.u.n. Bern

Langenthal
Langenthal Süd
Lotzwil
Gutenberg
Madiswil
Lindenholz
Kleindietwil
Rohrbach
Huttwil
Gondiswil
Hüswil
Zell
Gettnau
Gettnau Güteranlage
Willisau
Menznau West
Menznau
Wolhusen Weid
Wolhusen

0.00
1.62
3.42
4.39
6.04
7.52
8.44
10.54
14.09
18.03
19.81
21.69
25.17
26.30
28.75
33.66
34.68
37.71
39.32

v.u.n. Luzern

Wolhusen

v.u.n. Langnau

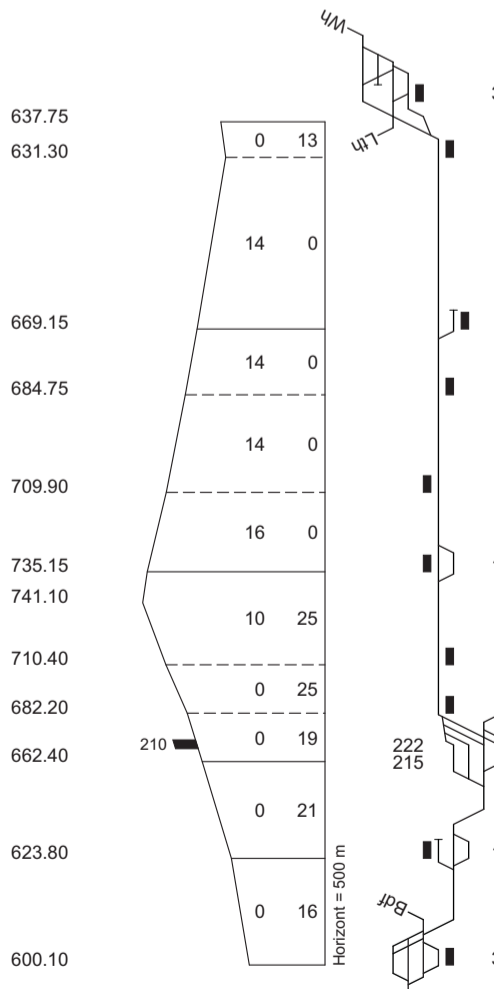

19.46
18.43
14.68
13.17
10.94
9.07
6.93
5.78
4.63
2.40
0.00

v.u.n. Burgdorf

Ramsei

v.u.n. Langnau

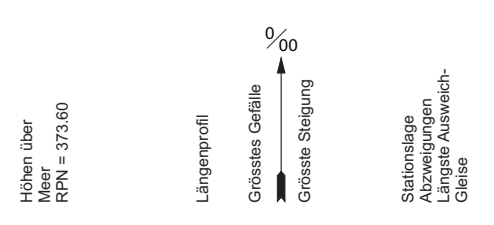

Entf. von Stat. zu Stat.
Kilometrierung der Bahn



I-FN-FPA-VPM

12 Dez 2010 - 10 Dez 2011

© SBB Fahrplan und Netzdesign

(Vers 23)

v. u. n. Zürich

00-12 Uhr

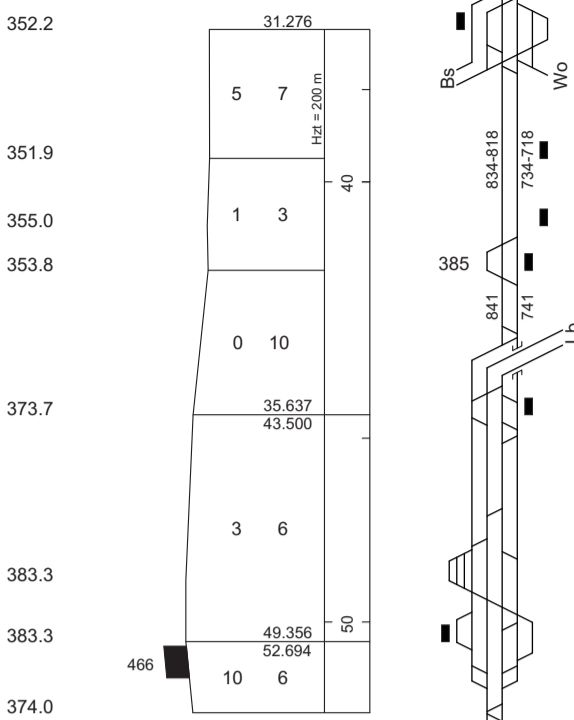

Höhen über Meer
RPN = 373.60

Längenprofil

Grösste Steigung

Grösstes Gefälle

Kilometrierung

Stationslage
Abzweigungen
Längste Ausweich-
Gleise

BRUGG (AG)		12.23
Schinznach Bad	4.87	7.36
Holderbank AG	2.61	4.75
Wildegg	1.66	3.09
Rupperswil	3.09	0.00 19.25
Rohr (Spw)	4.65	
AARAU	1.20	14.60
Wösch (Spw)	1.53	13.40
		11.87

Wösch - Rupperswil
Aussere Doppelspur
Gleis 052/055-162/165-839/737

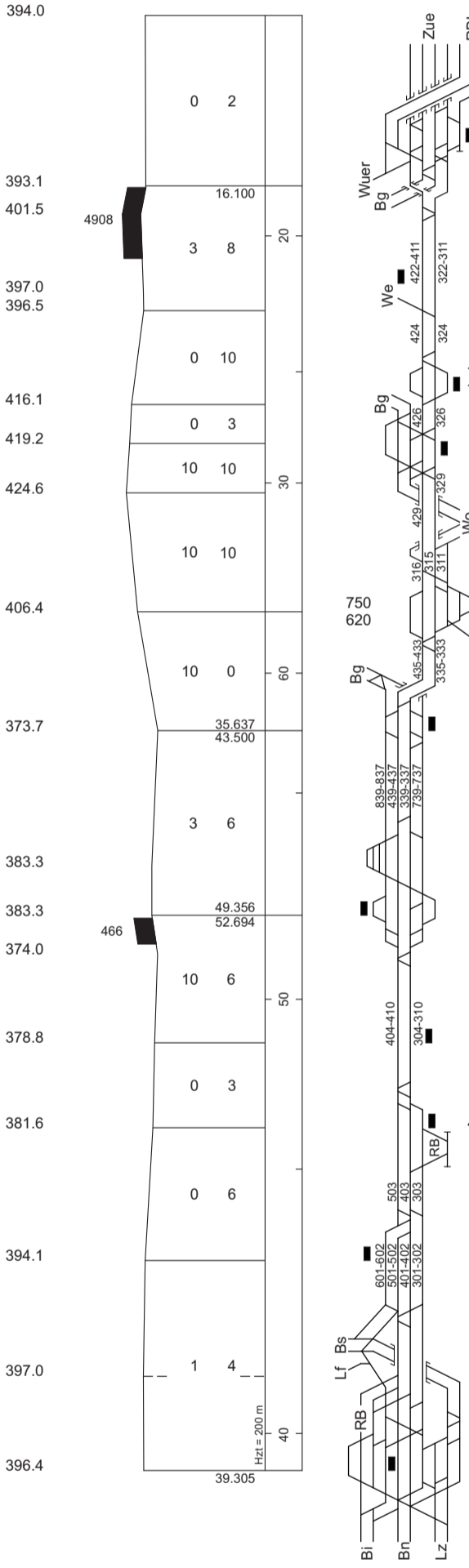

RB Limmattal	3.88	
Killwangen-Spreitenbach	1.30	38.70
Langacher (Spw)		37.40
Mellingen Heitersberg v. u. n. Wettingen Grüemet (Abzw)	5.61	31.79
Mägenwil	2.90	28.89
Othmarsingen	1.77	27.12
Gexi	2.29	24.83
Lenzburg	1.98	
v. u. n. Suhr		22.85
Rupperswil	3.60	19.25
Rohr (Spw)	4.65	
AARAU	1.20	14.60
Wösch (Spw)	1.53	13.40
Schönenwerd	3.03	11.87
Däniken	2.46	8.84
Dulliken	2.75	6.38
Olten Ost (Abzw)	3.63	3.63
Verbindungsline v. u. n. Basel		
OLTEN PB	3.55	0.00

Wösch - Rupperswil
Innere Doppelspur
Gleis 053/054-163/164-439/337

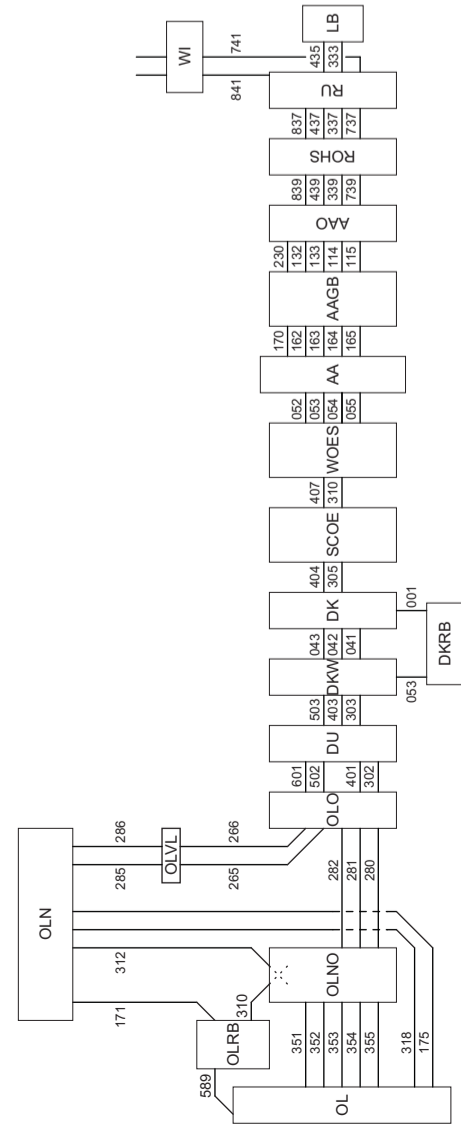

v. u. n. Bern

Dulliken

Olten Ost (Abzw)

v. u. n. Aarau

v. u. n. Basel

OLTEN

v. u. n. Biel/Bienne

v. u. n. Aarau

Däniken RB

v. u. n. Olten

Gl. 401



I-FN-FPA-VPM

12 Dez 2010 - 10 Dez 2011

© SBB Fahrplan und Netzdesign

(Vers 23)

00-12 Uhr

v. u. n. Basel

OLTEN PB

v. u. n. Luzern/Bern via ABO

v. u. n. Aarau

Gleise
351
352

+	OLTEN PB		37.30
+	Rothrist	5.86	31.44
+	Wanzwil (Abzw)	19.39	12.05
+	Inkwil (Verzw)	6.56	5.49
+	Subingen	2.45	3.04
+	Derendingen	3.04	0.00
+	SOLOTHURN		

v. u. n. Aarau

v. u. n. Basel

RB

PB

+	OLTEN		
+	Olten Hammer	1.33	60.07
+	Wangen bei Olten	2.42	58.74
+	Hägendorf	2.26	56.32
+	Härkingen Paketpost	2.14	54.06
+	Egerkingen	1.66	51.92
+	Oberbuchsiten	2.32	50.26
+	v. u. n. Balsthal	5.21	47.94
+	Oensingen	1.98	42.73
+	Niederbipp	5.69	40.75
+	Wangen a.d. Aare	3.30	35.06
+	Deitingen	2.75	31.76
+	Luterbach-Attisholz	3.46	29.01
+	v. u. n. Wanzwil	0.96	25.55
+	SOLOTHURN		
+	Solothurn West	2.88	24.59
+	v. u. n. Moutier	3.04	21.71
+	Bellach	2.19	18.67
+	Selzach	2.39	16.48
+	Bettlach	2.72	14.09
+	Grenchen Süd	2.22	11.37
+	v. u. n. Moutier	1.98	9.15
+	Lengnau	3.61	7.17
+	Pieterlen	0.44	3.56
+	Bann	3.12	3.12
+	Biel Mett (Abzw)		
+	Biel Mett		
+	BIEL PB		0.00

v. u. n. Neuchâtel

Biel Mett Abzw.

BIEL RB

v. u. n. Wiedlisbach

SOLOTHURN

v. u. n. Zollikofen

v. u. n. Bern

BIEL PB

Km
Kilometer
Entf. von Stat. zu Stat.
Entf. vom Ausgangspunkt



Meter
Höhen über Meer
RPN=373.60
Längenprofil

Grösste Steigung
Grösstes Gefälle
Kilometrierung

Stationslage
Abzweigungen
Längste Ausweich-
Gleise

Blockstationen
bzw. Blockstellen

34



SBB

I-FN-FPA-VPM

12 Dez 2010 - 10 Dez 2011

© SBB Fahrplan und Netzdesign

(Vers 23)

00-12 Uhr

Nordkopf

Basel St. Jakob

v. u. n. Basel GB

Basel GB VL

Ruchfeld

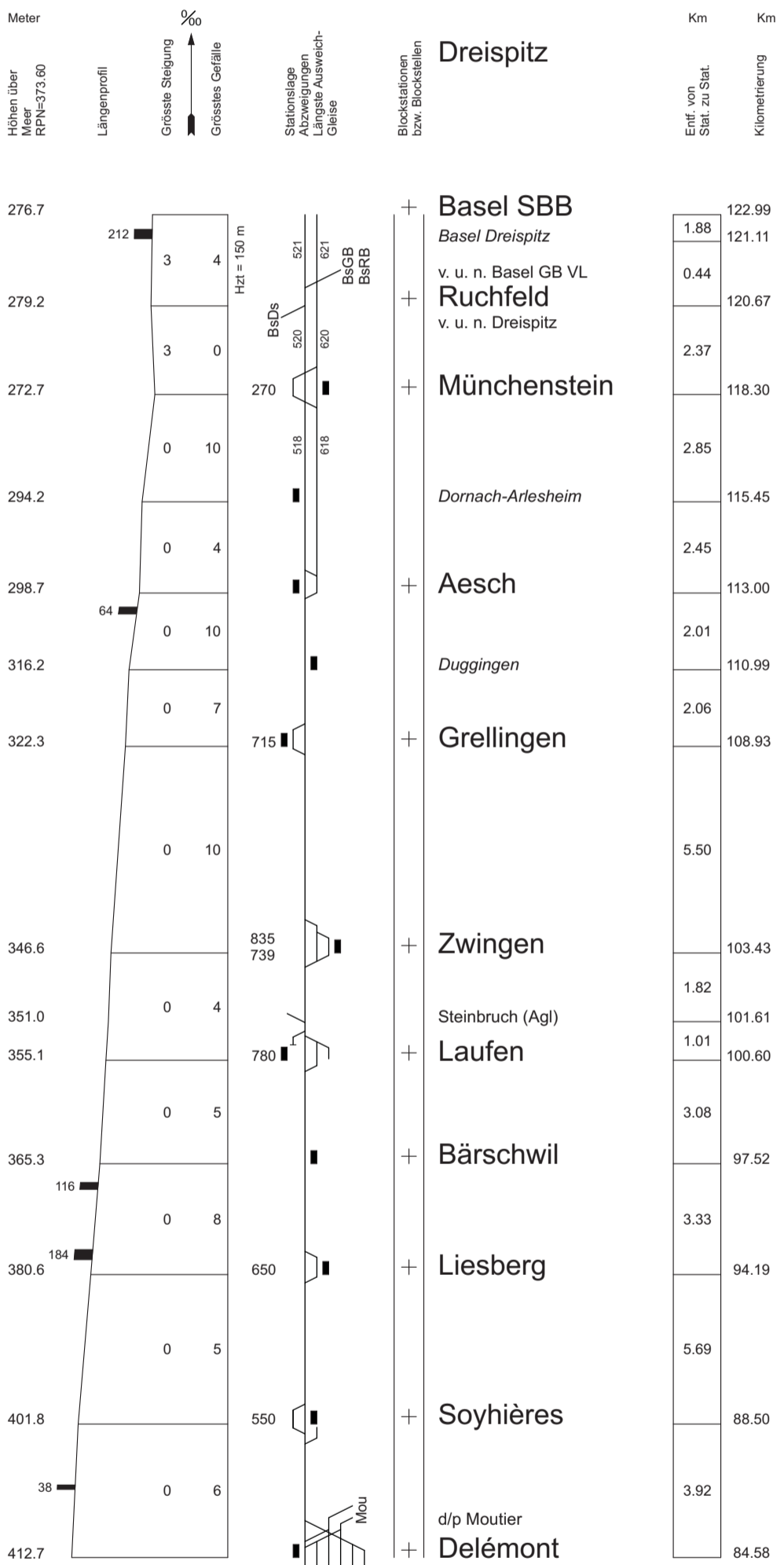

12 Dez 2010 - 10 Dez 2011
 © SBB Fahrplan und Netzdesign (Vers 23)

00-12 Uhr

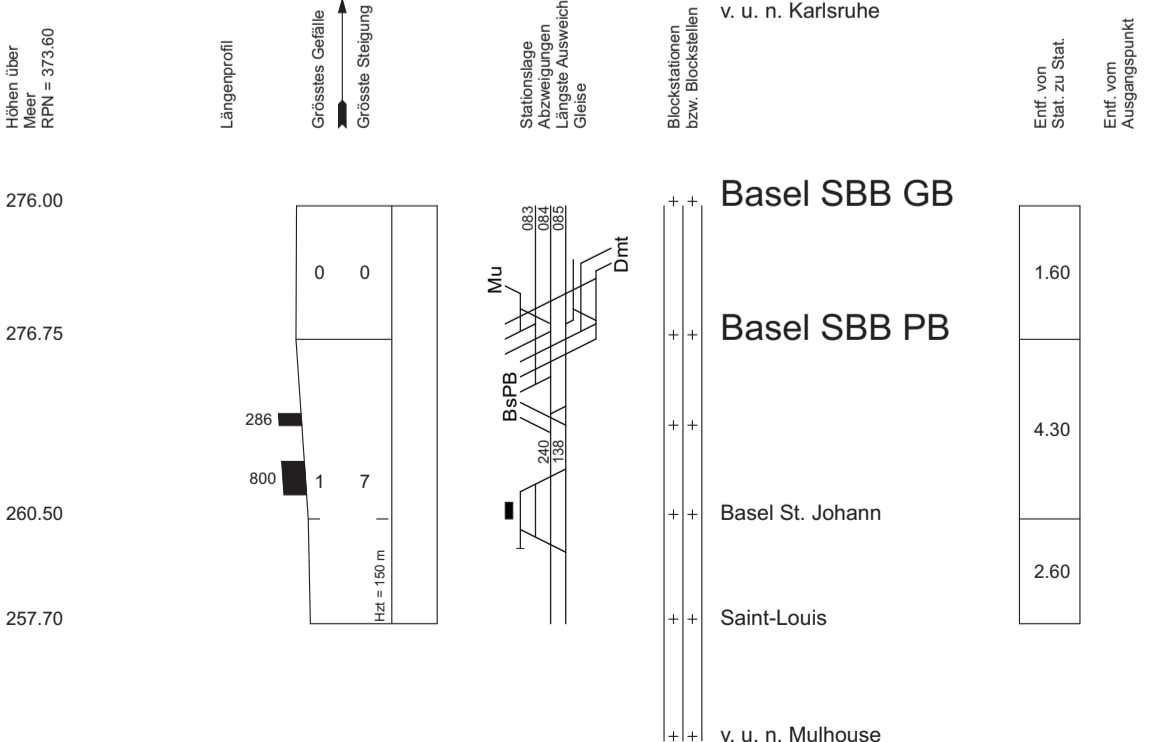
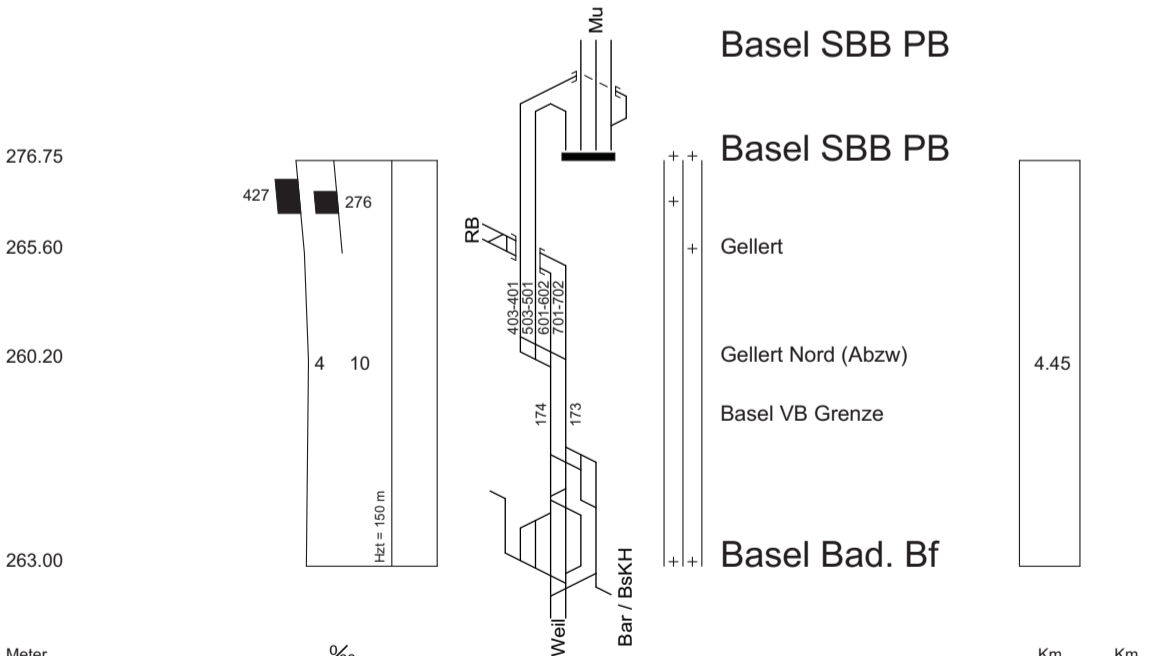
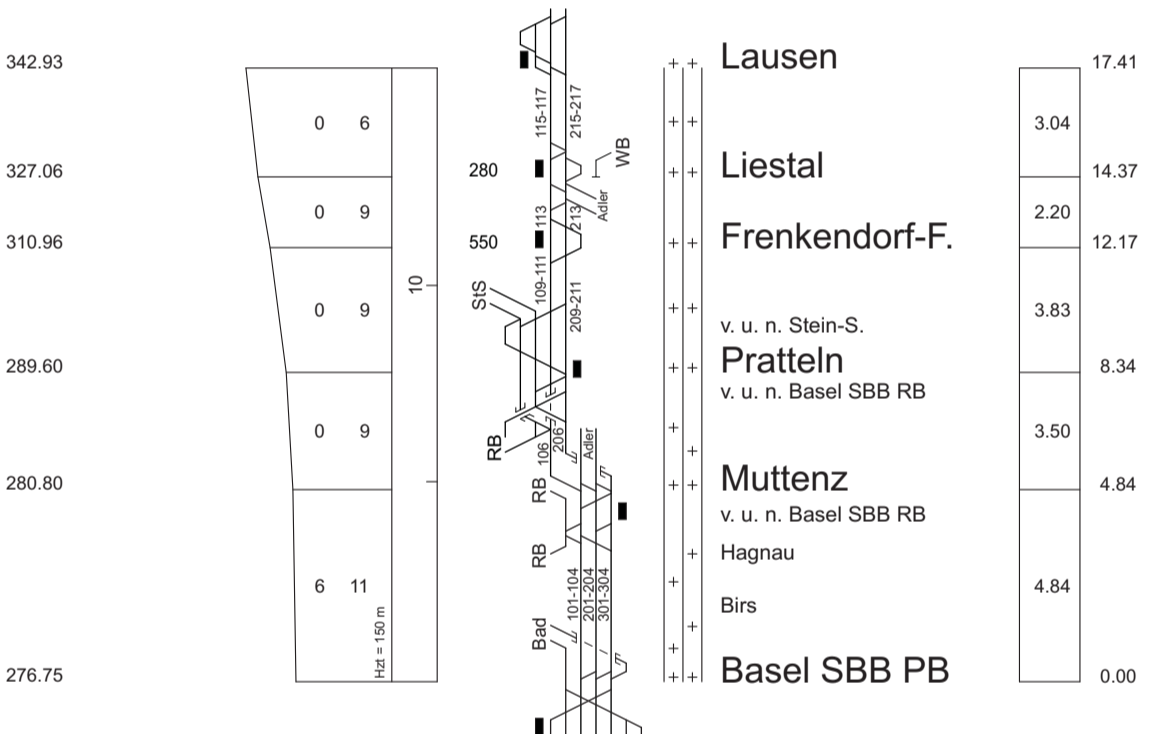
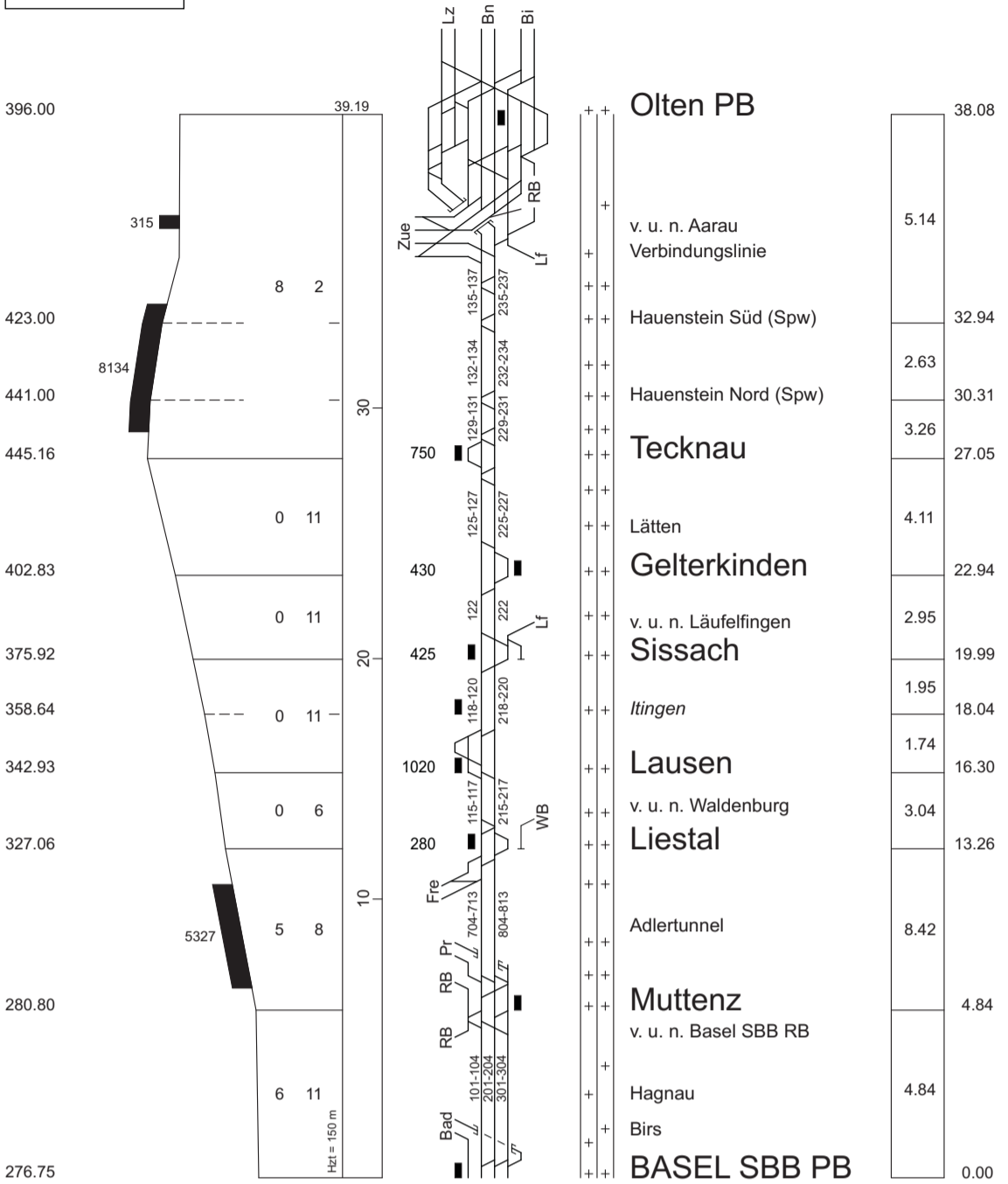

Höhen über Meer RPN = 373.60

Längenprofil
 Grösstes Gefälle
 Grösste Steigung

Stationslage
 Abzweigungen
 Längste Auswech-
 Gleise

Blockstationen bzw. Blockstellen

Entf. von Stat. zu Stat. Km
 Entf. vom Ausgangspunkt Km

00-12 Uhr

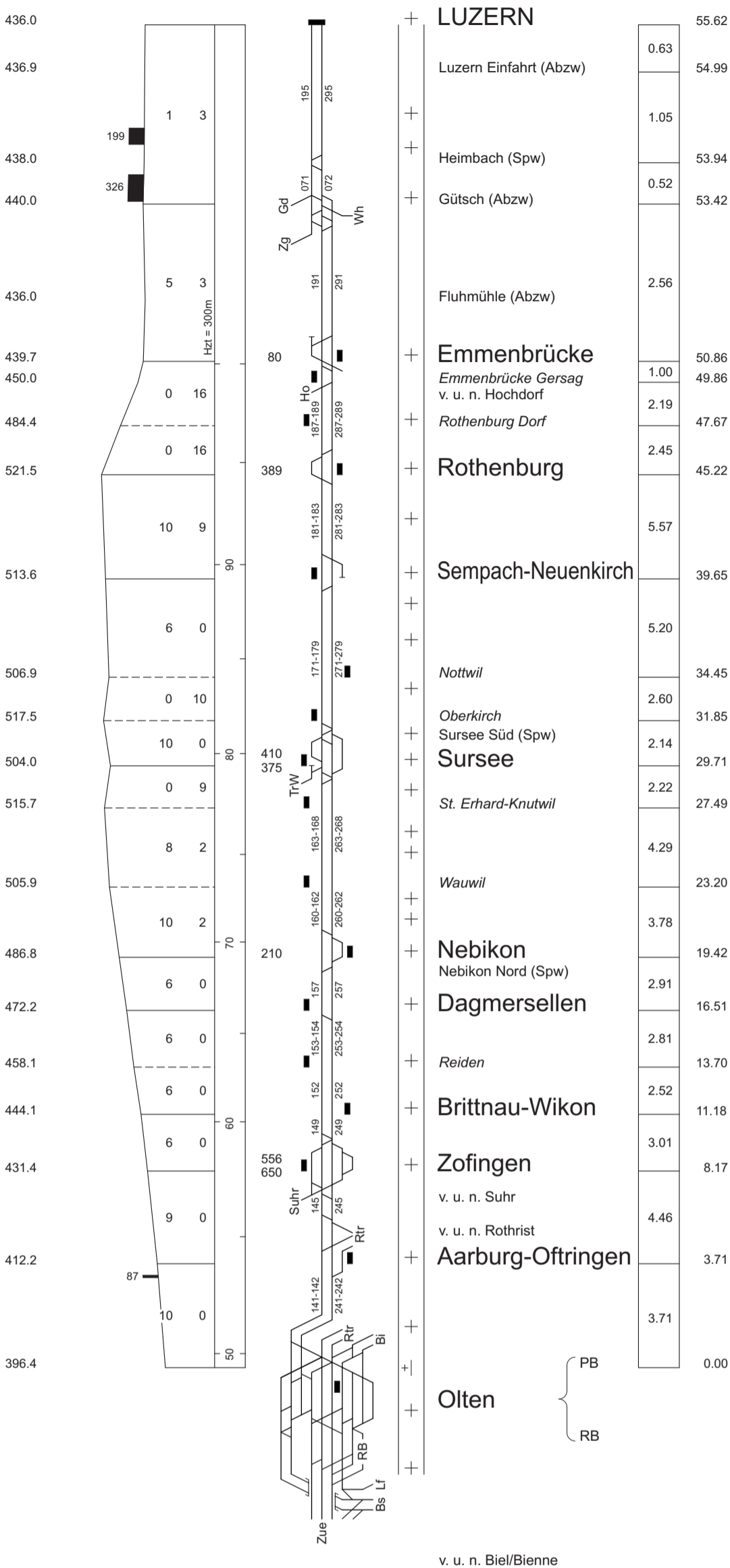

Meter

Höhen über Meer RPN = 373.60

Längenprofil

Grösste Steigung ‰

Grösstes Gefälle

Kilometrierung

Stationslage Abzweigungen Längste Auswech-Gleise

Blockstationen bzw. Blockstellen

Olten PB

v. u. n. Bern

Km

Entf. von Stat. zu Stat.

Km

Entf. vom Ausgangspunkt

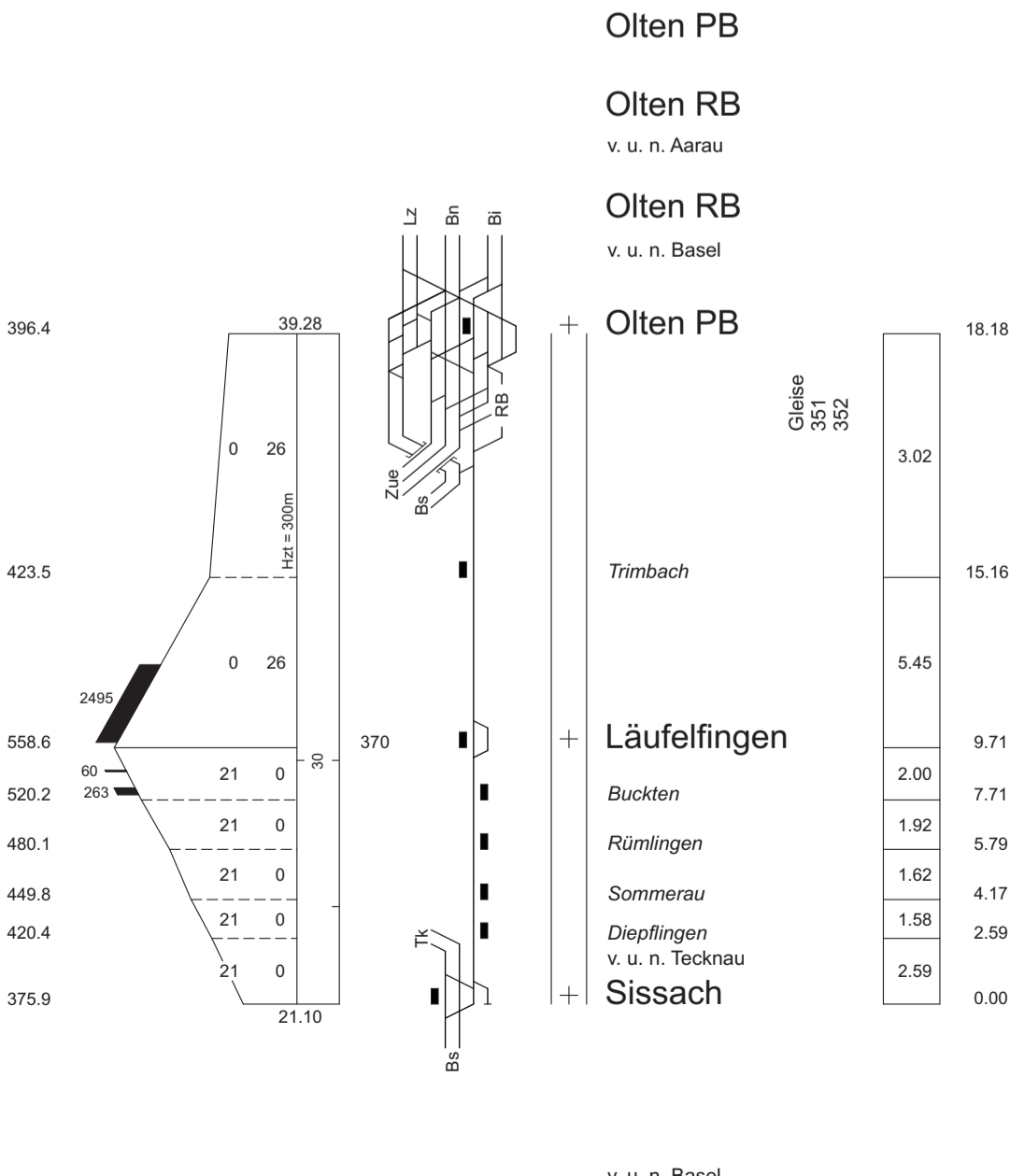



I-FN-FPA-VPM

12 Dez 2010 - 10 Dez 2011

© SBB Fahrplan und Netzdesign

(Vers 23)

00-12 Uhr

v. u. n. Brünig

LUZERN

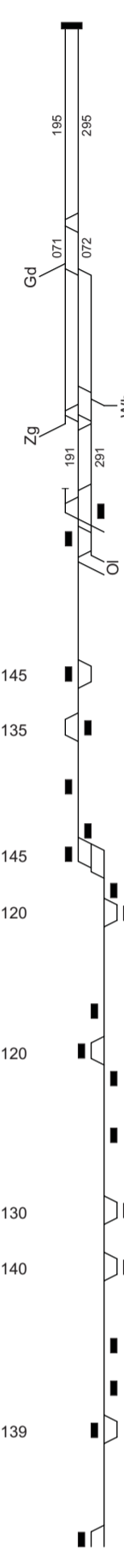
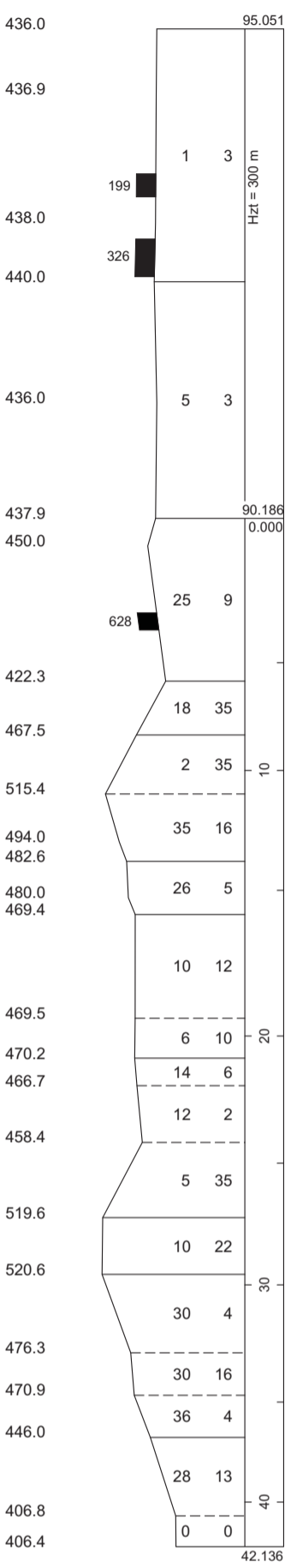

Station	Distance from Luzern (km)	Distance to Next Station (km)
LUZERN	46.91	
Luzern Einfahrt (Abzw)	46.28	0.63
Heimbach (Spw)	45.23	1.05
Gütsch (Abzw)	44.71	0.52
Fluhmühle (Abzw)		2.56
Emmenbrücke	42.15	1.00
Emmenbrücke Gersag v. u. n. Olten	41.15	
Waldibrücke	36.29	4.86
Eschenbach	33.57	2.72
Ballwil	31.15	2.42
Hochdorf Schönau	29.26	1.89
HOCHDORF	28.42	0.84
Baldegg Kloster	26.79	1.63
Baldegg	26.22	0.57
Gelfingen	22.78	3.44
Hitzkirch	21.35	1.43
Ermensee	20.27	1.08
Mosen	18.00	2.27
BEINWIL am See	14.94	3.06
Birrwil	12.63	2.31
Boniswil	9.06	3.57
Hallwil	7.53	1.53
Seon	5.28	2.25
Spitzkehre		5.28
LENZBURG	0.00	

Meter

Höhen über Meer
RPN = 373.60

Längenprofil

Grösste Steigung
Grösstes Gefälle

Kilometerung

Stationslage
Abzweigungen
Längste Ausweich-
Gleise

Blockstationen
bzw. Blockstellen

LENZBURG

Km

Km

Entf. von Stat. zu Stat.

Entf. vom Ausgangspunkt

Hendschiken

Gexi

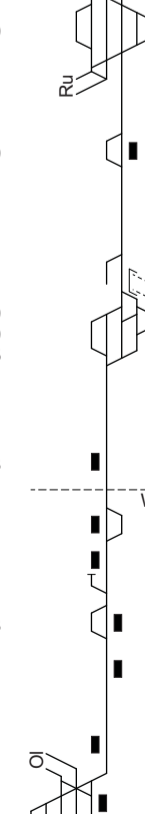
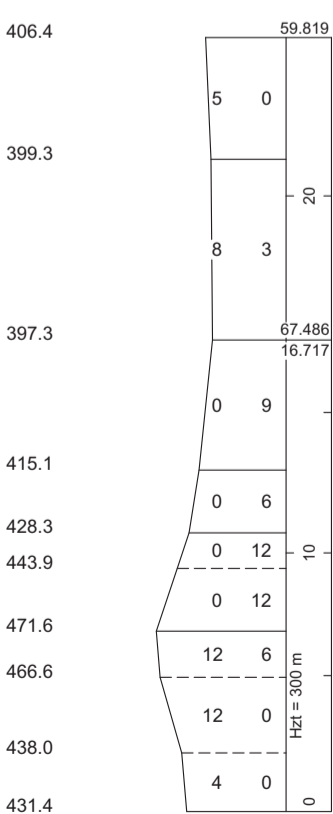

Station	Distance from Rapperswil (km)	Distance to Next Station (km)
LENZBURG	24.38	3.44
Hunzenschwil	20.94	3.20
Suhr Migros	17.74	1.02
Suhr	16.72	3.09
Oberentfelden	13.63	2.74
Kölliken	10.89	1.61
Kölliken Oberdorf Kölliken Sondermülldeponie	9.28	2.72
Safenwil	6.56	1.62
Walterswil-Striegel	4.94	2.65
Küngoldingen v. u. n. Olten	2.29	2.29
ZOFINGEN	0.00	2.29

v. u. n. Luzern

I-FN-FPA-VPM

12 Dez 2010 - 10 Dez 2011

© SBB Fahrplan und Netzdesign

(Vers 23)

12-24 Uhr

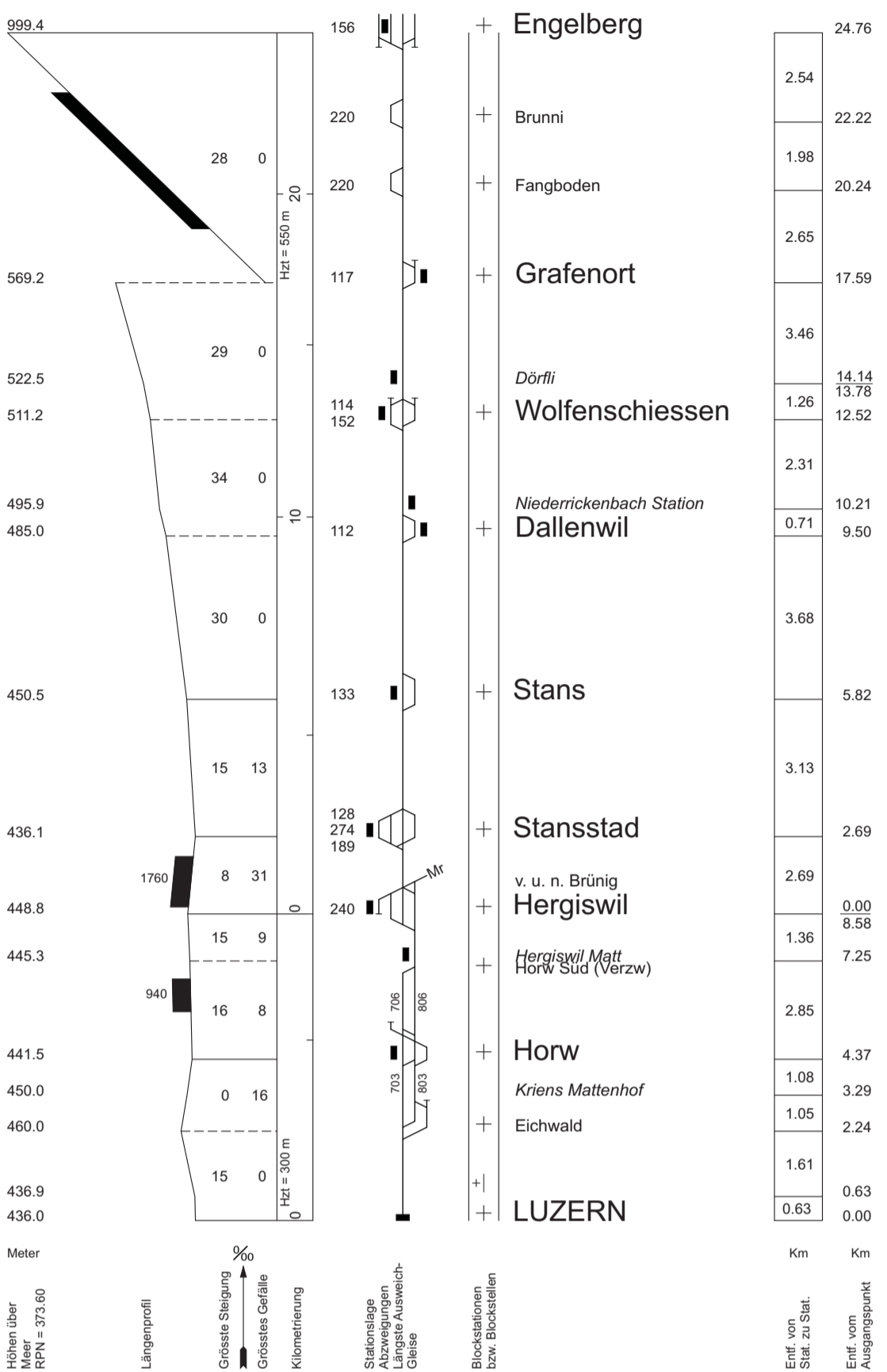

00-12 Uhr

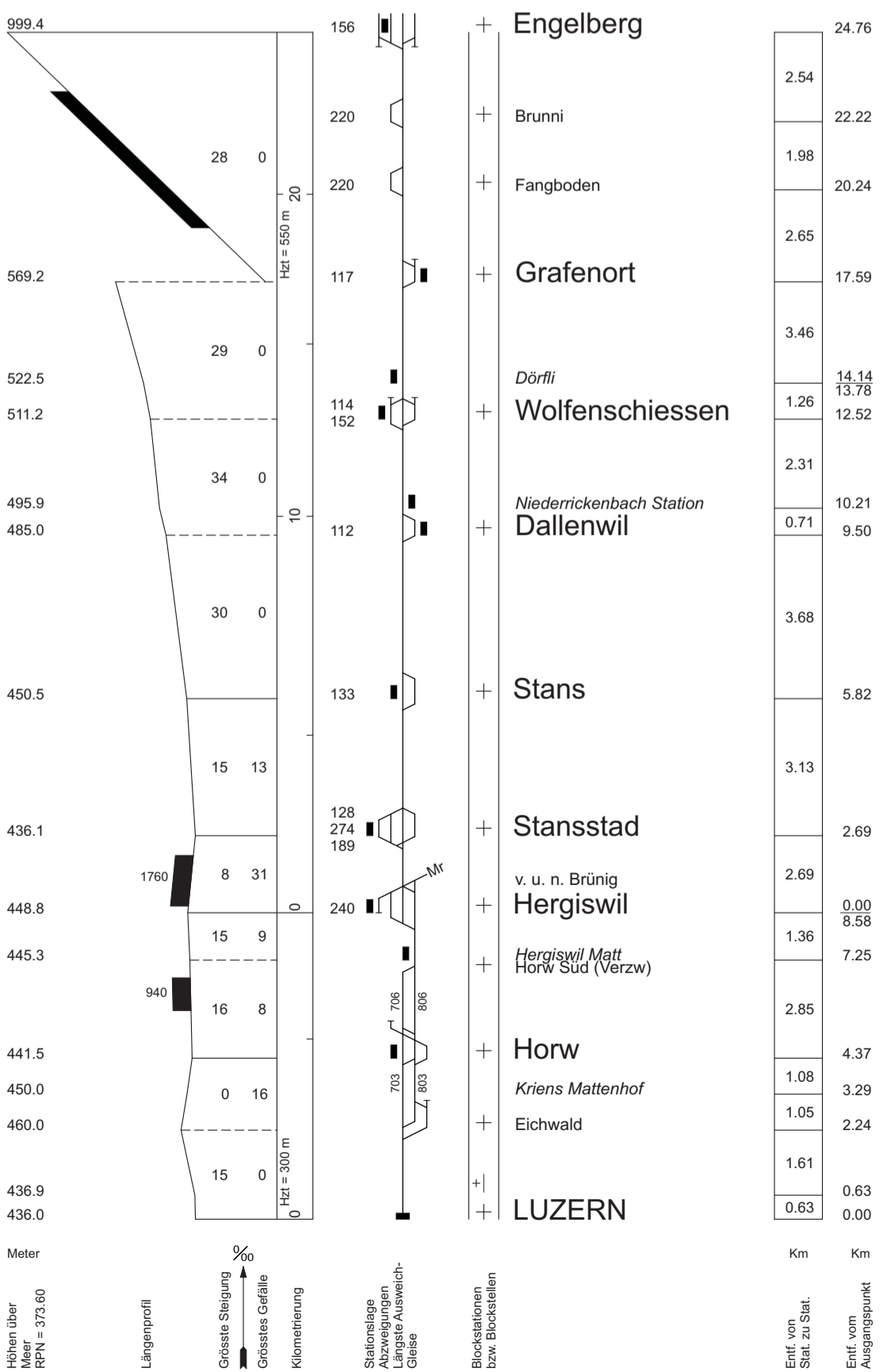

45



I-FN-FPA-VPM

12 Dez 2010 - 10 Dez 2011
© SBB Fahrplan und Netzdesign (Vers 23)

INTERLAKEN OST

v. u. n. Zweilütschinen

v. u. n. Interlaken West

INTERLAKEN OST

00-12 Uhr

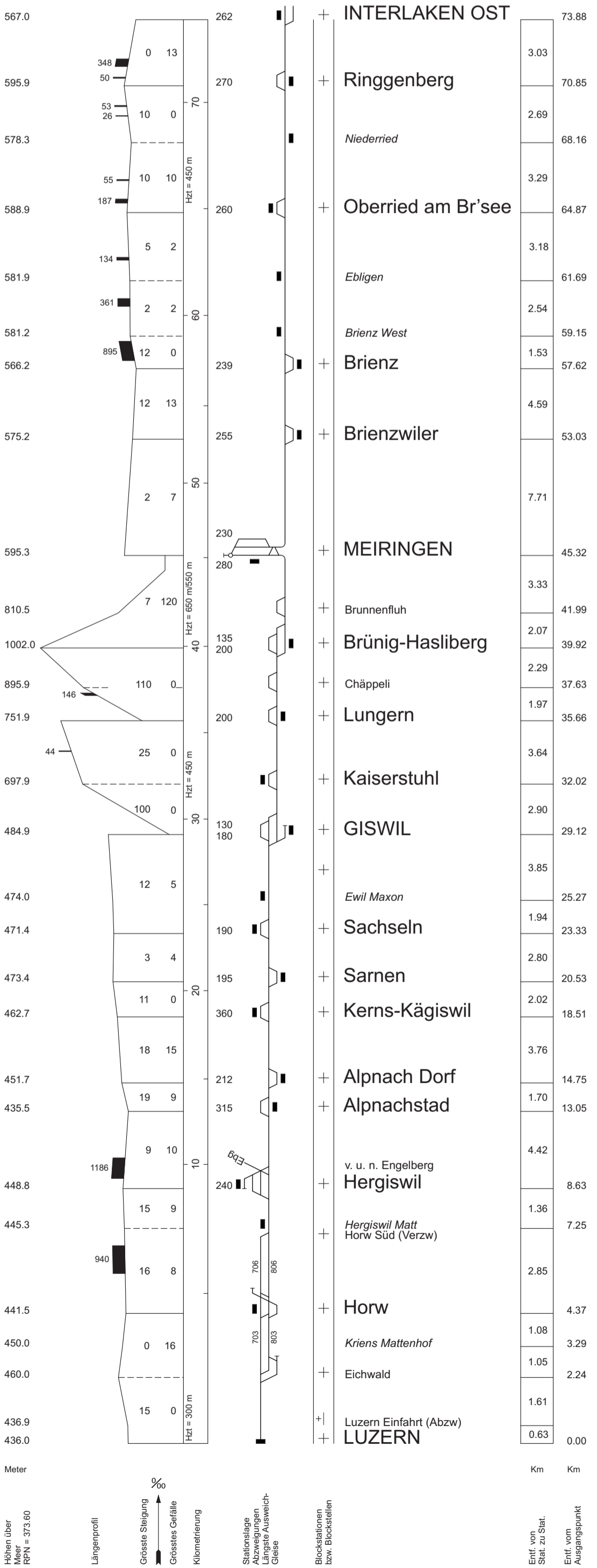

Höhen über Meer
RPN = 373.60

Längenprofil

Grösste Steigung
Grösstes Gefälle

Kilometrierung

Stationslage
Abzweigungen
Längste Ausweich-
Gleise

Blockstationen
bzw. Blockstellen

Entf. von Stat. zu Stat.

Entf. vom Ausgangspunkt

00-12 Uhr

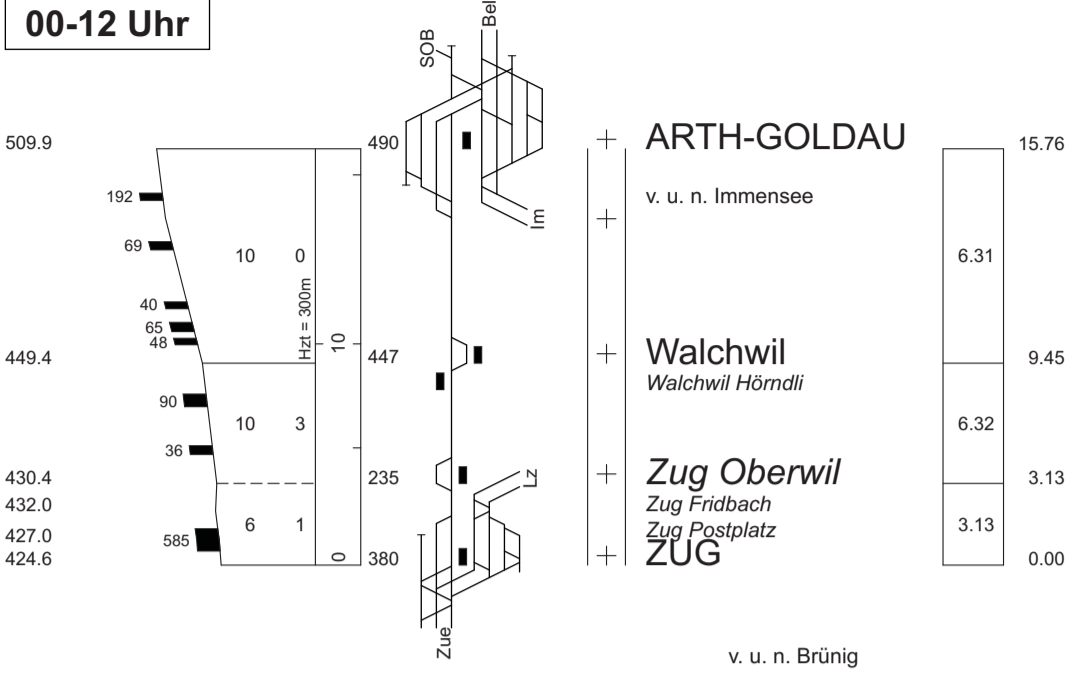

v. u. n. Brüinig

LUZERN

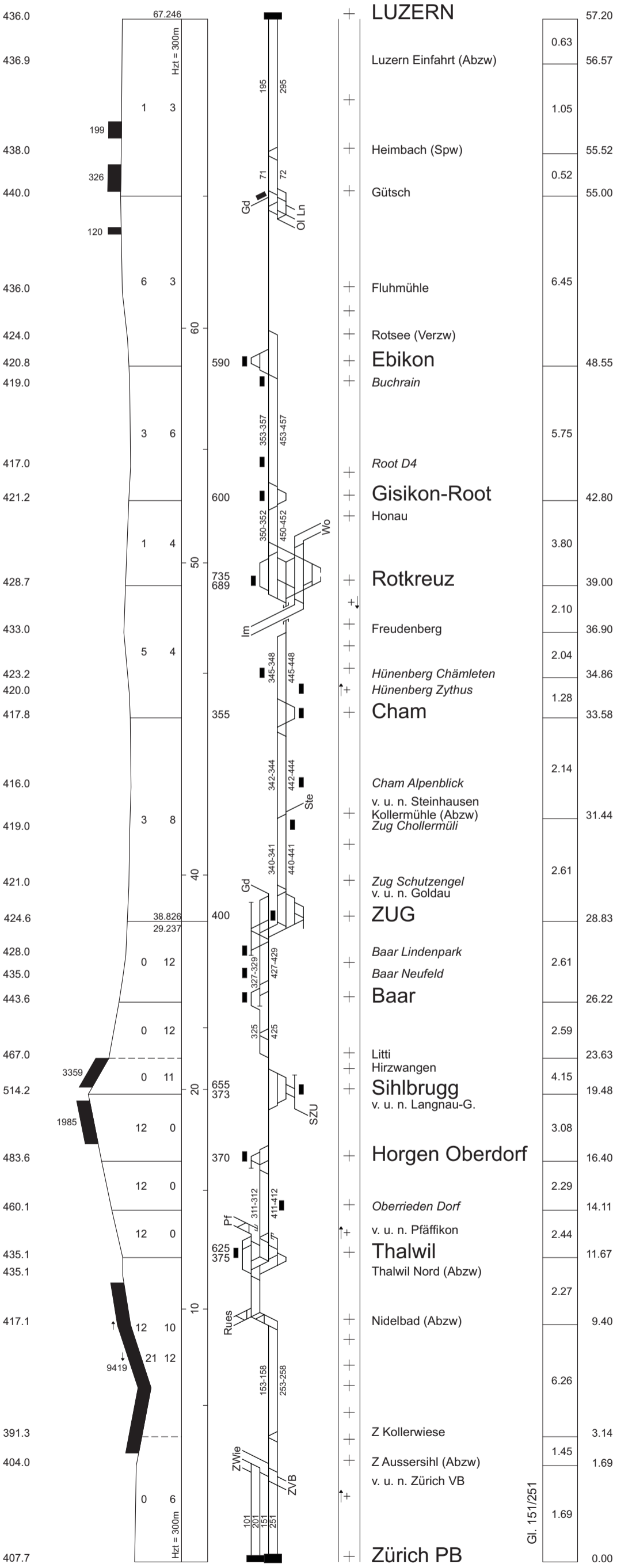

Gl. 151/251

Zch Aussersihl

Zch Vorbahnhof

Meter

Höhen über Meer = 373.60

Längenprofil

Grösste Steigung
Grösstes Gefälle
Kilometrierung

Stationslage
Abzweigungen
Längste Ausweichgleise

Blockstationen bzw. Blockstellen

Entf. von Stat. zu Stat.

Entf. vom Ausgangspunkt

Km

Km



SBB

51

I-FN-FPA-VPM

12 Dez 2010 - 10 Dez 2011

© SBB Fahrplan und Netzdesign

(Vers 23)

00-12 Uhr

Lupfig

v. u. n. Othmarsingen

Brugg AG Süd (Abzw)
Brugg VL
Brugg AG Nord (Abzw)

Turgi

v. u. n. Zürich

Brugg AG

Brugg AG Nord (Abzw)

Villnachern (Spw)

Schinznach Dorf

Effingen

Kirchmatt (Spw)

Hornussen

Buchhalde (Spw)

Frick

Niederfeld (Spw)

Eiken

v. u. n. Koblenz

Stein-Säckingen

Mumpf

Dossenboden (Spw)

Möhlin

Rheinfelden

Rheinfelden Augarten

Kaiseraugst

Pratteln Salina Raurica

Pratteln

Muttenz

Basel SBB PB

Basel St. Johann

St-Louis

v. u. n. Mulhouse-Ville

Pratteln

Basel RB Gr D

Pratteln

Basel RB Gr E

Basel RB Gr G

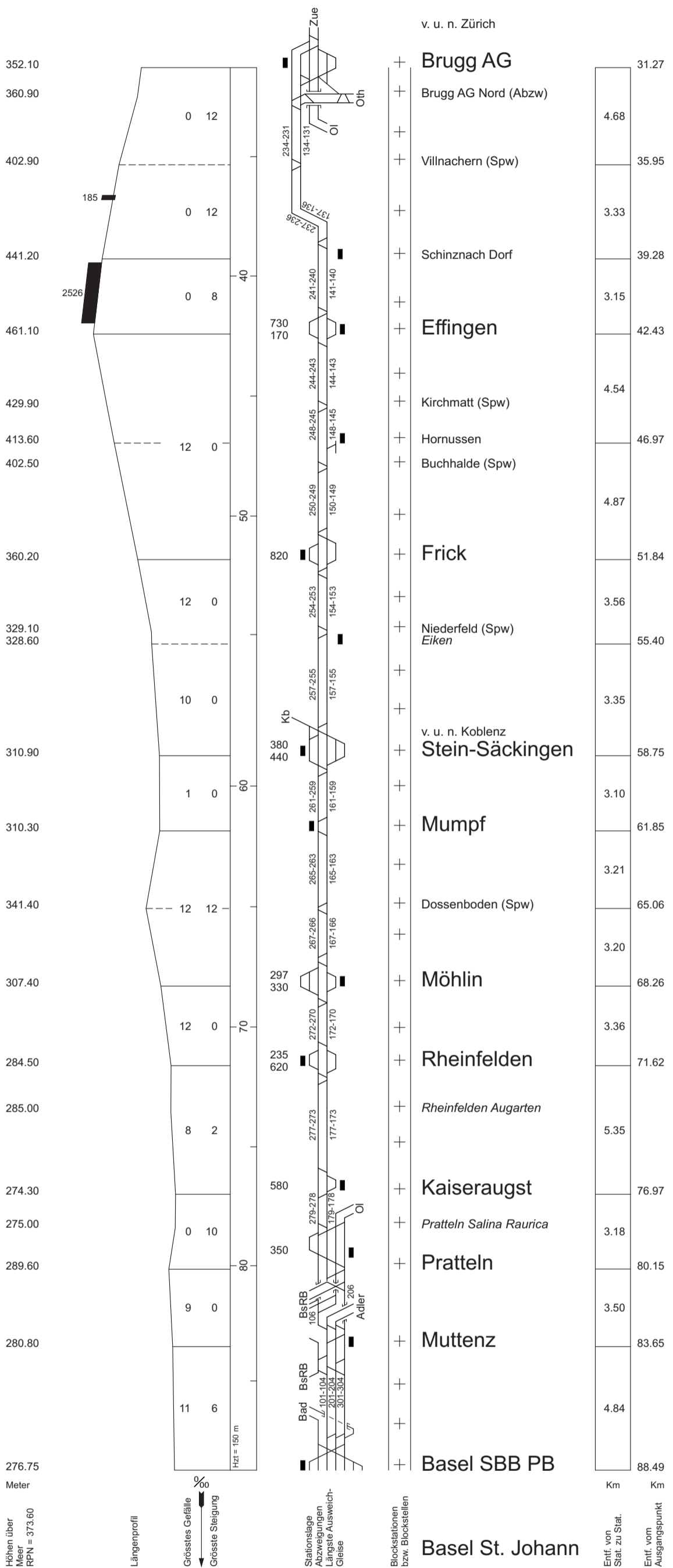



I-FN-FPA-VPM

12 Dez 2010 - 10 Dez 2011
© SBB Fahrplan und Netzdesign (Vers 23)

00-12 Uhr

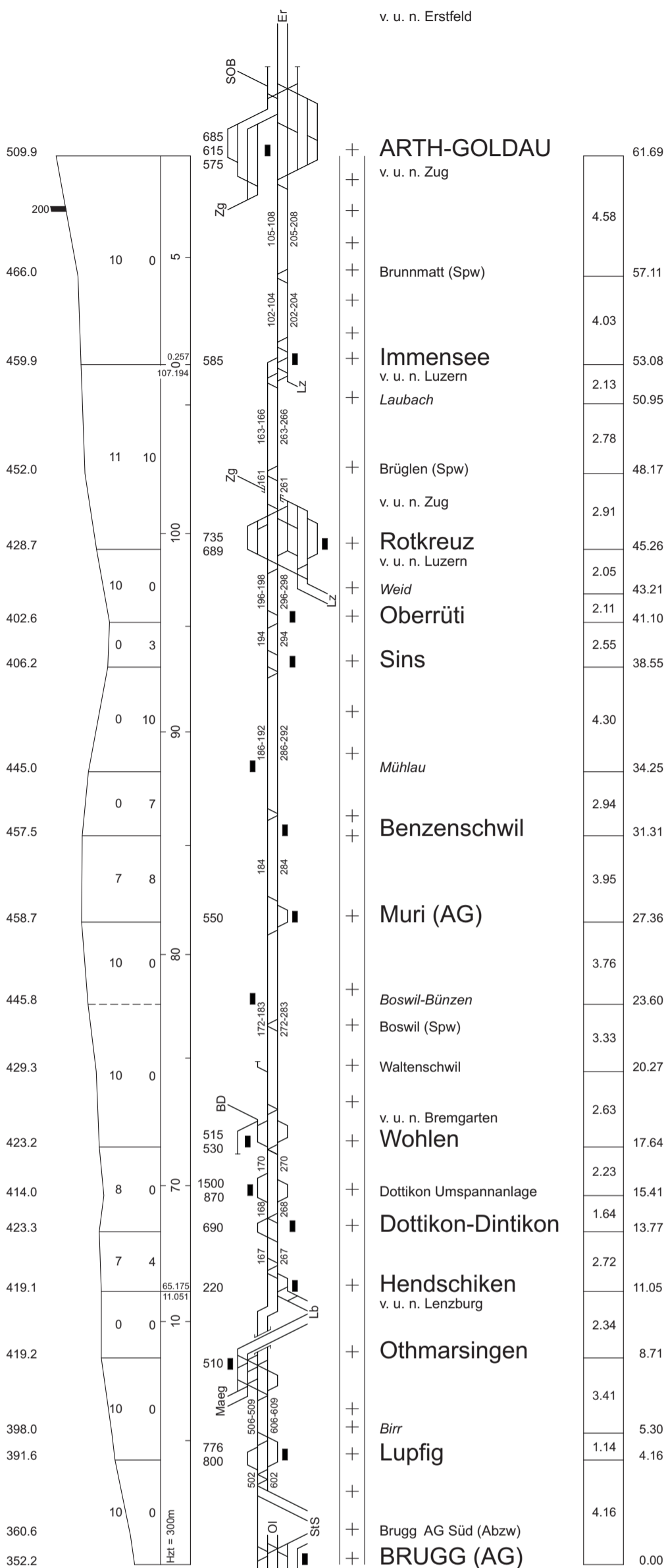

Meter
v. u. n. Basel
Km
Km
Höhen über Meer: RPN = 373.60
Längsenprofil
Grösste Steigung
Grösstes Gefälle
Kilometrierung
Stationslage
Abzweigungen
Längste Ausweichgleise
Blockstationen bzw. Blockstellen
Entf. von Stat. zu Stat.
Entf. vom Ausgangspunkt

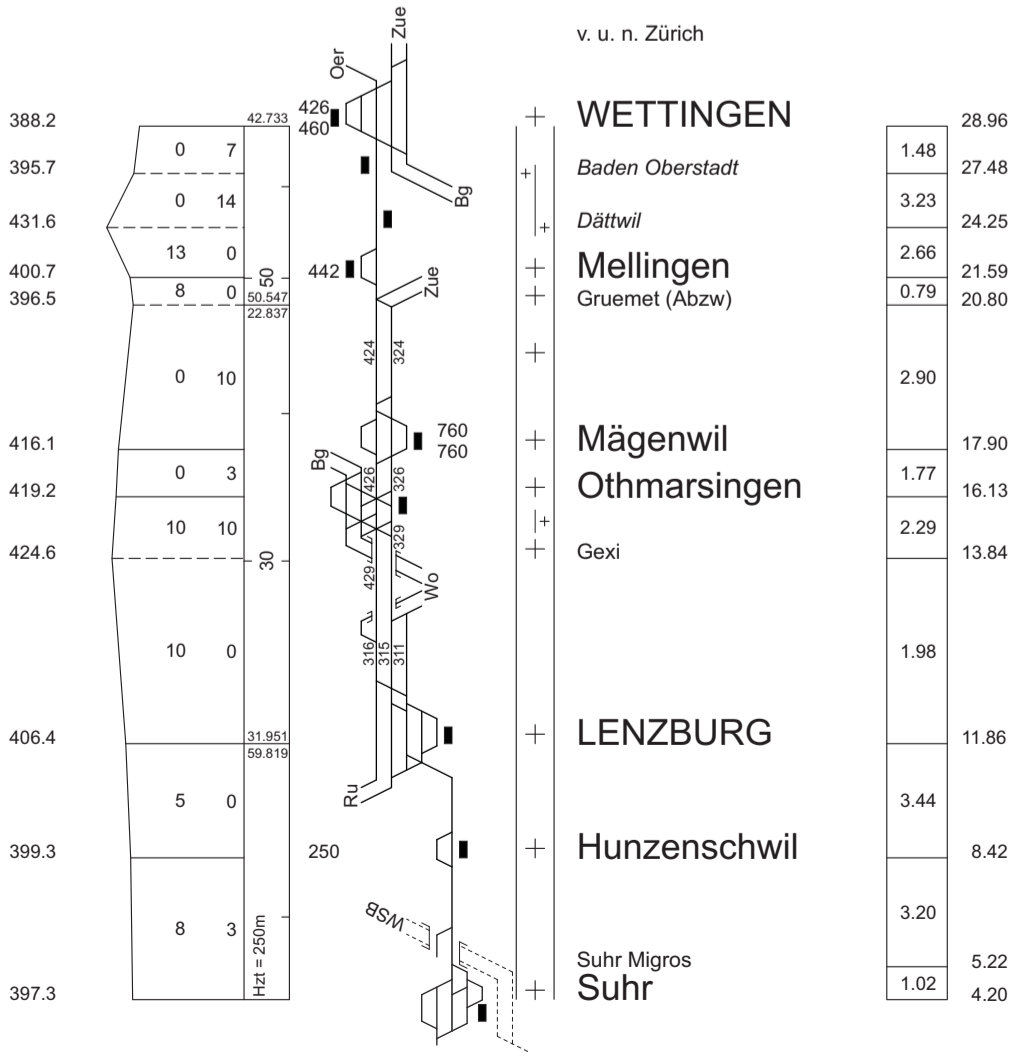

53



SBB

I-FN-FPA-VPM

12 Dez 2010 - 10 Dez 2011

© SBB Fahrplan und Netzdesign

(Vers 23)

00-12 Uhr

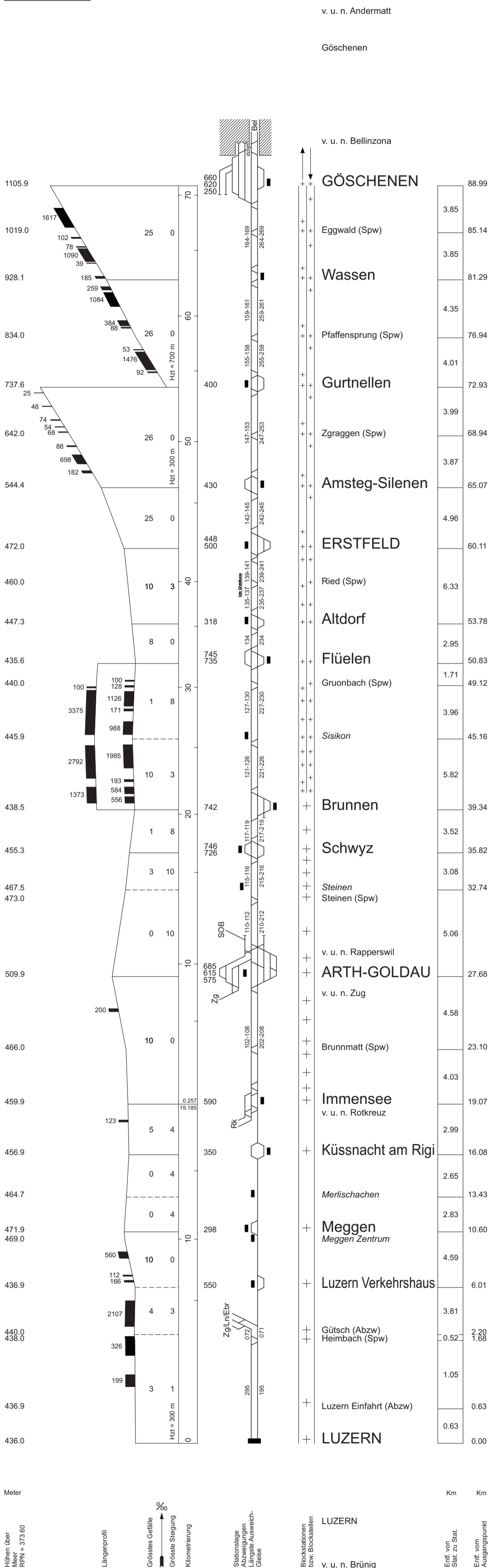

Höhen über Meer
RPN = 373.60

Längenprofil

Grösstes Gefälle
Grösste Steigung
Kilometrierung

Stationslage
Abzweigungen
Längste Ausweichgleise

Blockstationen bzw. Blockstellen

LUZERN
v. u. n. Brünig

Entf. von Stat. zu Stat.

Entf. vom Ausgangspunkt

v. u. n. Andermatt

Göschenen

v. u. n. Bellinzona

GÖSCHENEN

	88.99
Eggwald (Spw)	3.85
Wassen	3.85
Pfaffensprung (Spw)	4.35
Gurtellen	4.01
Zraggen (Spw)	3.99
Amsteg-Silenen	3.87
ERSTFELD	4.96
Ried (Spw)	4.01
Atdorf	6.33
Flüelen	2.95
Gruonbach (Spw)	1.71
Sisikon	3.96
Brunnen	5.82
Schwyz	3.52
Steinen	3.08
Steinen (Spw)	5.06
ARTH-GOLDAU	5.06
v. u. n. Zug	4.58
Brunnmatt (Spw)	4.03
Immensee	4.03
v. u. n. Rotkreuz	2.99
Küssnacht am Rigi	2.65
Merlischachen	2.83
Meggen	2.83
Meggen Zentrum	4.59
Luzern Verkehrshaus	6.01
Gütsch (Abzw)	3.81
Heimbach (Spw)	0.52
Luzern Einfahrt (Abzw)	1.05
LUZERN	0.63
	0.00

Km

Km



I-FN-FPA-VPM

12 dicembre 2010 - 10 dicembre 2011

© SBB Fahrplan und Netzdesign

(Vers 23)

00-12 ore

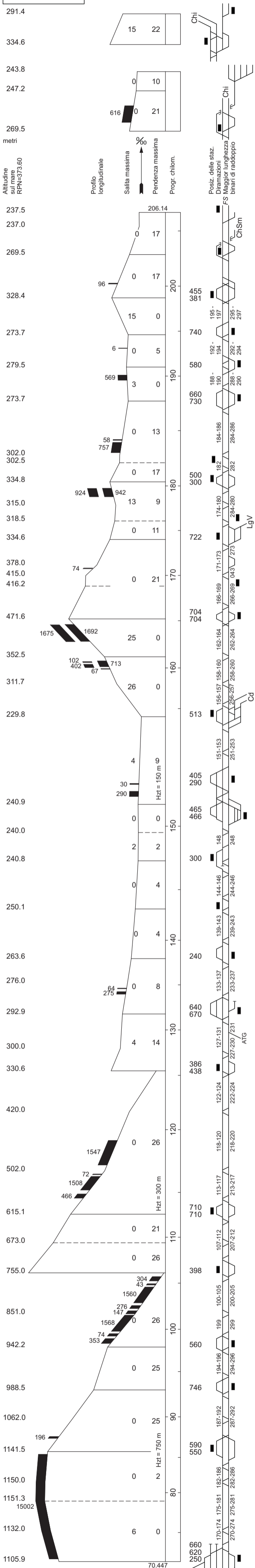

da e per Como

Chiasso		
Lugano Veduggio	107.34	
Taverne-Torricella	3.79	103.55
Chiasso SM	U	135.61
	L	134.56
Balerna		133.06
Chiasso		135.67
Balerna	2.61	133.06
Mendrisio	4.82	128.24
Capolago-R.S.V.	4.10	124.14
Maroggia-Melano	3.58	120.56
Melide	3.81	116.75
Lugano Paradiso (c bin)		112.74
Lugano Paradiso	0.37	112.37
Lugano	2.39	109.98
Lamone (c bin)	2.58	107.40
Lamone-Cadempino da e per Lugano Veduggio	1.77	105.63
Taverne-Torricella	2.08	103.55
Sigirino	2.70	100.85
Mezzovico (c bin)	1.30	99.55
Mezzovico	1.17	98.38
Rivera-Bironico	3.64	94.74
Al Motto (c bin)	3.82	90.92
Vigana (c bin)	3.35	87.57
da e per Luino/Locarno	4.00	
Giubiasco		93.57
	3.15	
Bellinzona Sud		
Bellinzona		80.42
Bellinzona Collegamento S. Paolo	1.13	79.29
Bellinzona Nord (bif)	2.50	76.79
Castione-Arbedo		76.79
	3.79	
Claro		73.00
	5.51	
Osogna-Cresciano		67.49
Giustizia (dira)	6.17	
Biasca		61.32
Pasquierio (bin rac)		
Pollegio Nord	6.29	
Bodio		55.03
	4.37	
Giornico (c bin)		50.66
	3.70	
Pianotondo (c bin)		46.96
	4.84	
Lavorgo		42.12
Chiggiona (c bin)	3.19	38.93
	3.36	
Faido		35.57
	4.10	
Pardorea (c bin)		31.47
	4.10	
Rodi-Fiesso		27.37
	4.79	
Ambri-Piotta		22.58
Sordo (c bin)	3.37	19.21
	3.47	
Airolo		15.74
Gottardo Sud (c bin)	4.89	10.85
	5.95	
Gotthard Nord (Spw)		4.90
	4.90	
Göschenen		0.00

55



FFS

I-FN-FPA-VPM

12 dicembre 2010 - 10 dicembre 2011

© SBB Fahrplan und Netzdesign

(Vers 23)

00-12 ore

da e per Domodossola

Locarno

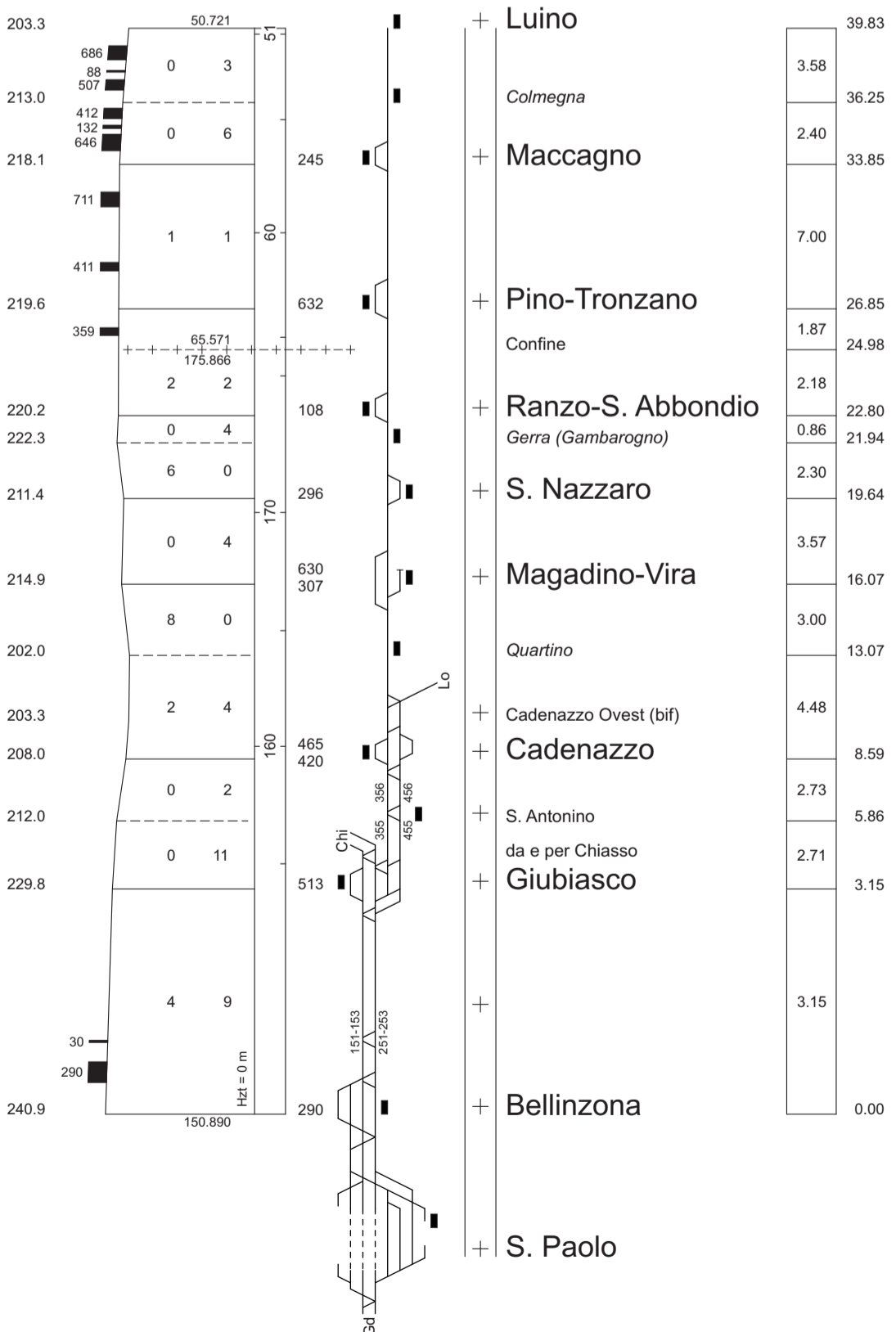

da e per Airolo

metri

Km

Km

Altitudine sul mare
RFN=373.60

Profilo longitudinale

Salita massima
Pendenza massima

Progr. chilom.

Posiz. delle staz.
Diramazioni
Maggior lunghezza
binari di raddoppio

Staz. di blocco
risp. posti di blocco

Dist. fra le stazioni

Dist. dal punto di origine



SBB 16 A

I-FN-FPA-VPM

12 Dez 2010 - 10 Dez 2011 (Vers 23)

© SBB Fahrplan und Netzdesign

Mellingen Heitersberg

v/n Lenzburg

0-6

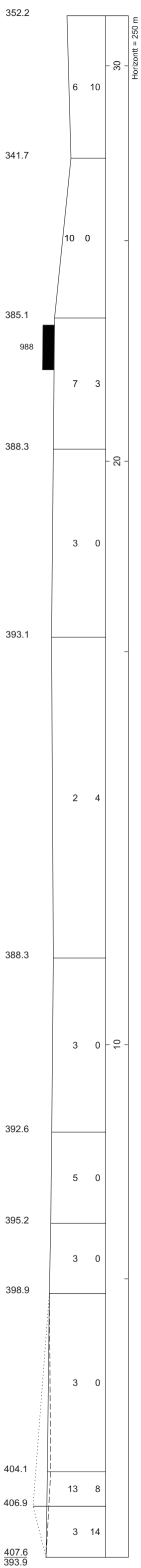

Langacher Killwangen-S	16.11
4.99	
Dietikon	11.12
Glanzenberg	1.62
2.00	9.50
Schlieren	7.50
3.34	
Z Altstetten	4.16
Z Hardbrücke West (Spw)	2.24
Z Hardbrücke 5+6	1.92
Z Langstrasse	1.92
Zürich PB A3-18	0.00

Brugg Nord v/n Basel	
Brugg AG	31.27
v/n Koblenz	3.84
Turgi	27.43
4.90	
Baden	22.53
2.27	
Wettingen	20.26
v/n Z Seebach	1.50
Neuenhof	18.76
2.65	
Killwangen-S	16.11
2.80	
Silbernen (Abzw)	13.31
Dietikon	2.19
11.12	
Glanzenberg	1.62
9.50	
Schlieren	2.00
7.50	
Einfang (Abzw)	1.19
6.31	
2.15	
Z Altstetten	4.16
Z Hardbrücke 1+4	2.24
1.92	
Z Langstrasse	1.92
Zürich PB S21-24	0.00

Einfang (Abzw)	0.65
Z Mülligen	0.94
Z Altstetten	
Gl. 242/142	2.08
Zürich VB	
Zürich VB Nord	
Gl. M 1-3	2.08
Zürich PB A3-18	

Z Altstetten	
Gl. 215	1.37
Zürich VB West (Feld Z)	0.71
Zürich VB	
Z Altstetten	
Gl. 694	2.08
Zürich VB	
Zürich VB Ost Gl. 691/791	2.08
Zürich PB A3-18	
Q51-54	

Urdorf	
v/n Zug	4.41
Z Altstetten	2.35
Hard Käferberg (Abzw)	
	3.08
Z Oerlikon	



I-FN-FPA-VPM

12 Dez 2010 - 10 Dez 2011 (Vers 23)

© SBB Fahrplan und Netzdesign

0-12

Baden Oberstadt

v/n Lenzburg

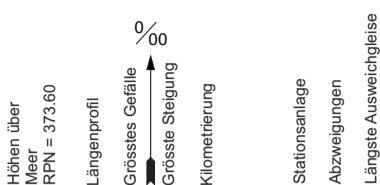

Wettingen

Entfernung von Stat. zu Stat.	
Entfernung vom Ausgangspunkt	

Killwangen-S.

2.35	
------	--

Würenlos

Baden

v/n Brugg

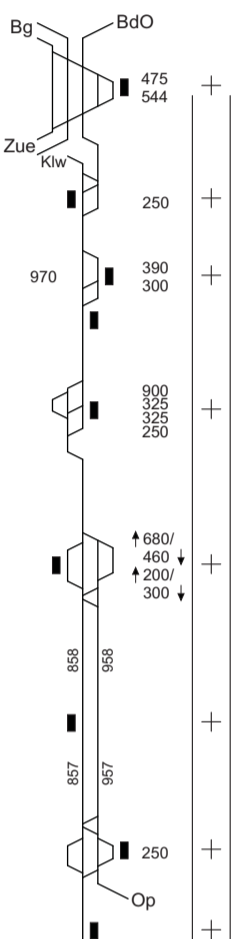
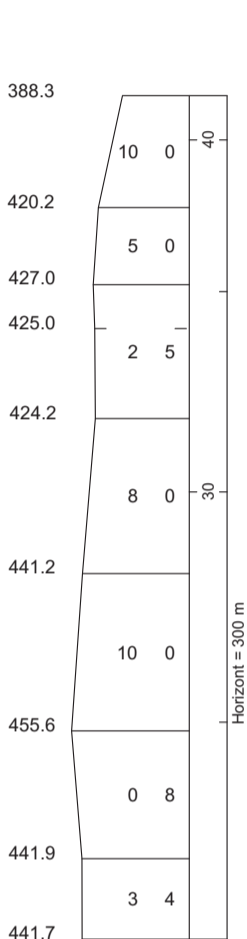

Wettingen

0.00	
------	--

v/n Killwangen

Würenlos

3.69	
------	--

Otelfingen

2.52	
------	--

Otelfingen Industrie
Otelfingen Golfpark

6.21	
------	--

Buchs-Dällikon

0.75	6.96
0.37	7.33

1.48	
------	--

8.81	
------	--

1.06	9.87
------	------

Regensdorf-Watt

3.36	
------	--

13.23	
-------	--

Z Affoltern

3.41	
------	--

16.64	
-------	--

Z Seebach

2.78	
------	--

19.42	
-------	--

Z Oerlikon

1.31	
------	--

20.73	
-------	--

Z Affoltern

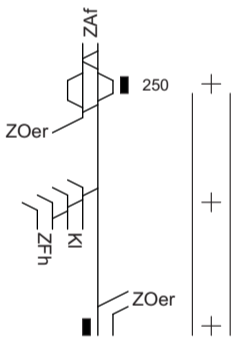
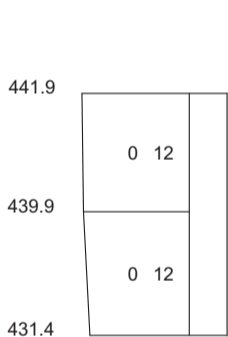

Z Seebach

19.42	
-------	--

Opfikon Süd

1.10	
------	--

20.52	
-------	--

Glattbrugg

0.90	
------	--

21.42	
-------	--

v/n Bülach

Tankanlage Rümlang

Opfikon Süd

Opfikon

v/n Kloten

Riet

Z Altstetten

Z Herdern

Z Hardbrücke

Z Langstrasse

Zürich PB S21-24

Z Herdern

Zürich VB Nord

Gl. M1-3

Zürich PB A3-18 Q51-54

Zürich VB Nord

Gl. 591

Zürich PB A3-18 Q51-54

RBL 18

0-12

12 Dez 2010 - 10 Dez 2011 (Vers 23)
© SBB Fahrplan und Netzdesign

Mellingen-Heitersberg

v/n Lenzburg

Langacher Killwangen-S

Neuenhof

v/n Brugg

Killwangen-S

Würenlos

v/n Z Seebach

Killwangen-S

Killwangen-S

GI 010 / 110 / 210

RBL K

RBL E

RBL K

RBL U

RBL M

RBL L

RBL B

RBL Z

RBL K

RBL Tivoli

RBL West

Killwangen-S

GI 310

RBL N

RBL M

RBL L

Silberer

RBL L

RBL A

RBL Z

RBL N

RBL U

RBL N

RBL R

RBL Z

RBL D

RBL Z

RBL E

RBL West

RBL Ost

RBL Z

v/n Zürich
GI 208 / 308

Dietikon

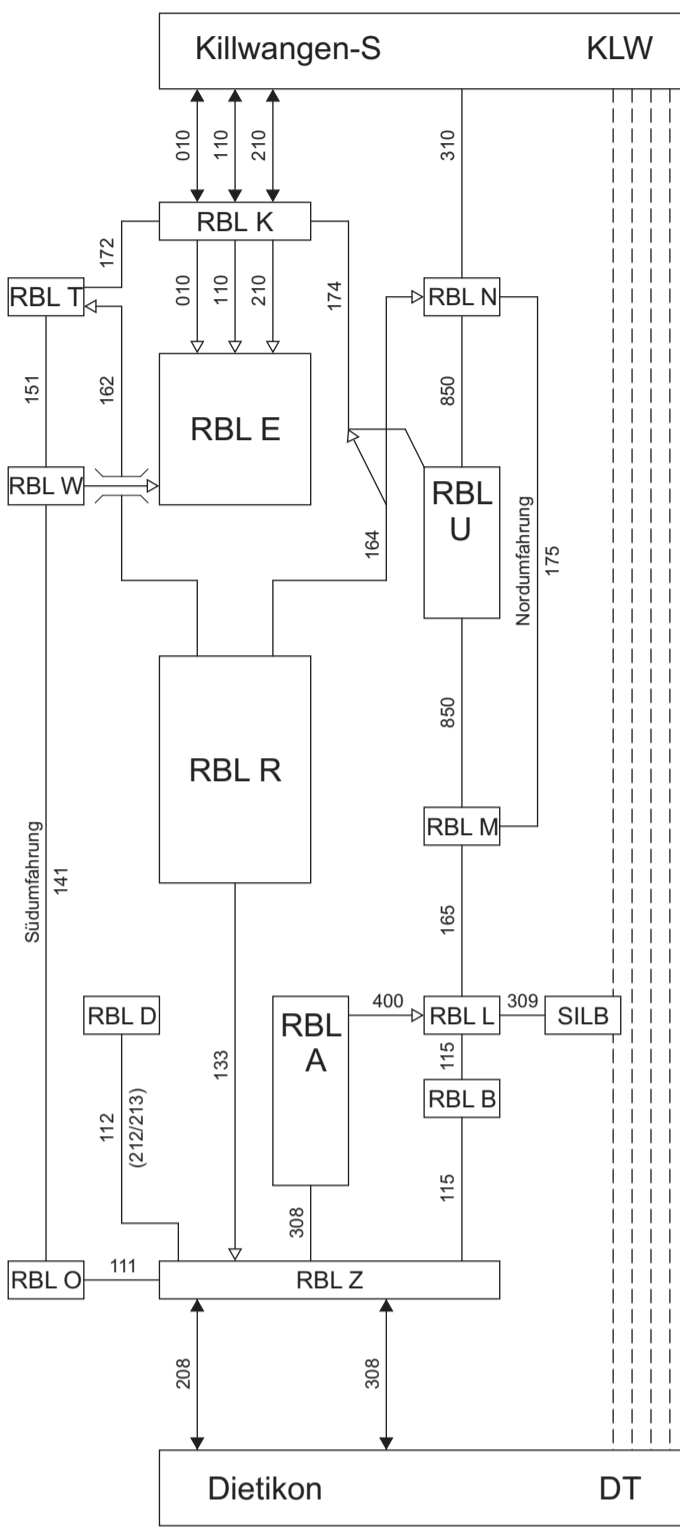

↔ Wechselbetrieb
◁ ▹ Obligatorische Fahrrichtung



SBB 60

I-FN-FPA-VPM

12 Dez 2010 - 10 Dez 2011 (Vers 23)

© SBB Fahrplan und Netzdesign

Winterthur GB

0-12

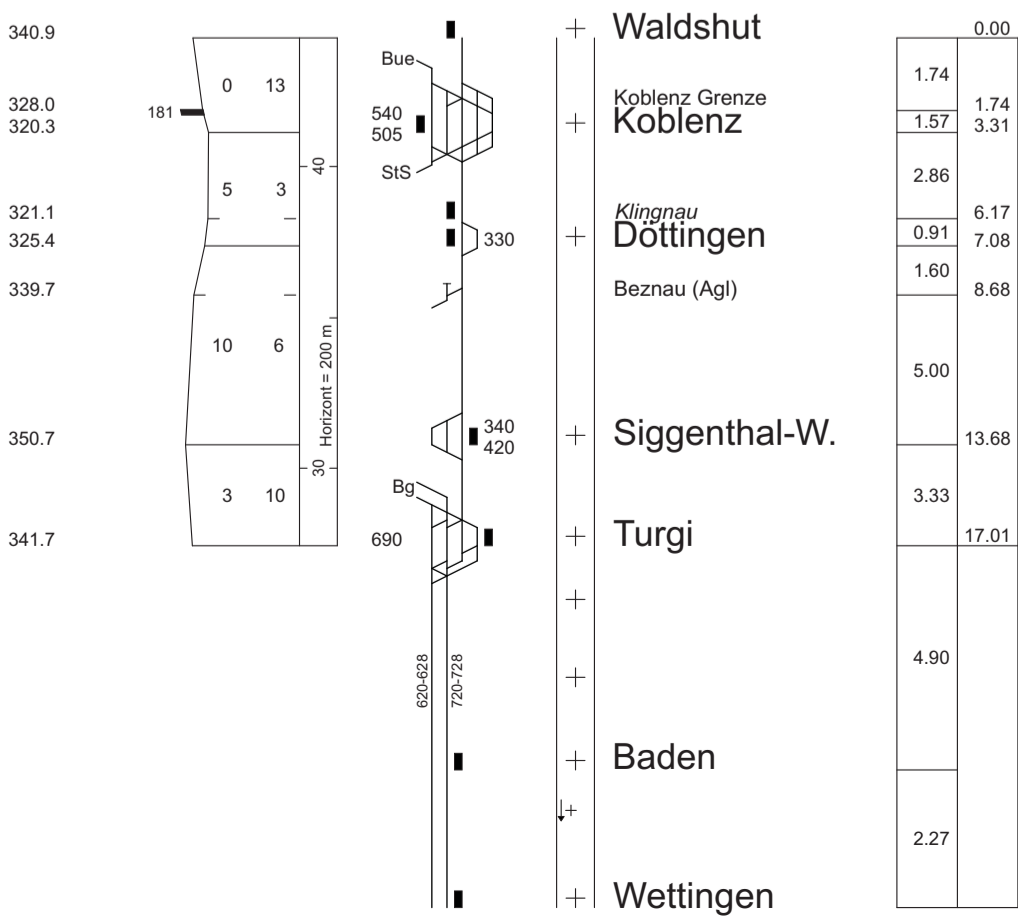
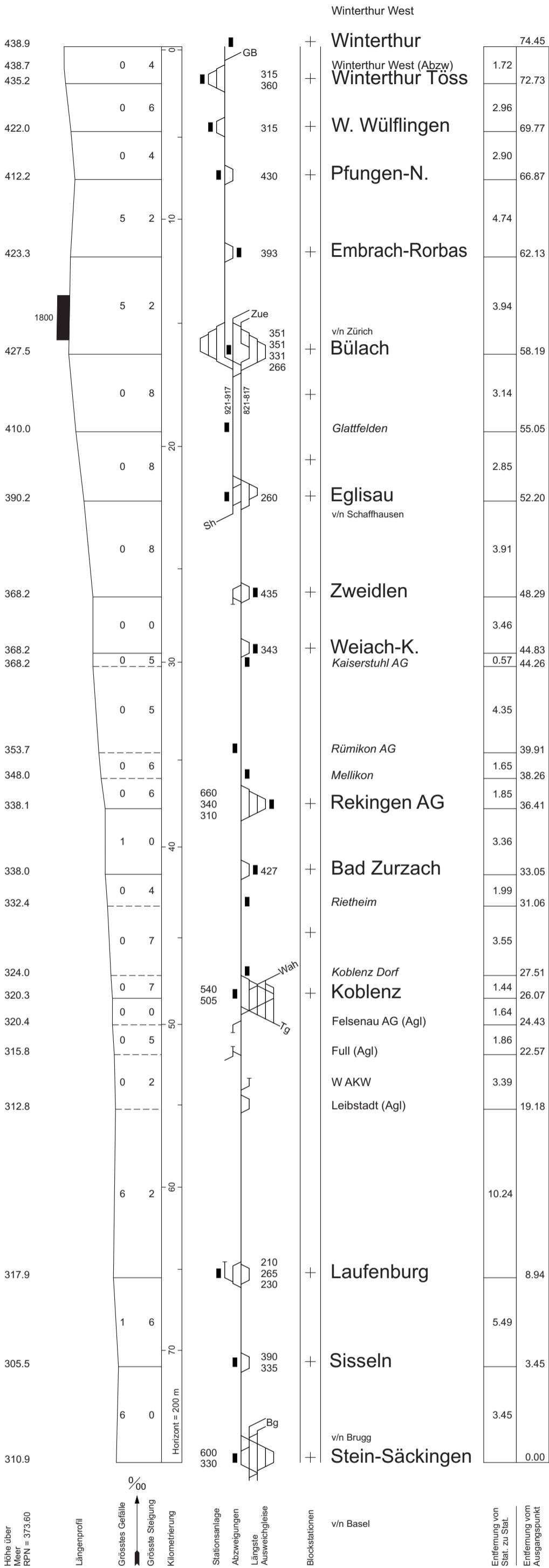



SBB 61

I-FN-FPA-VPM

12 Dez 2010 - 10 Dez 2011 (Vers 23)

0-12

© SBB Fahrplan und Netzdesign

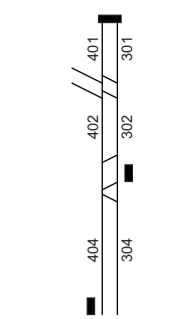
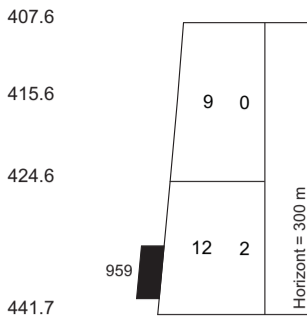

+	Zürich PB A 3-18 Q 51-54	0.00
+	Z Viadukt (Abzw)	1.40
+	Z Wipkingen	1.49
+	Z Oerlikon	2.42
+		5.31

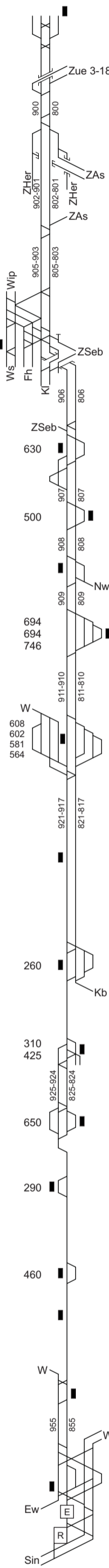
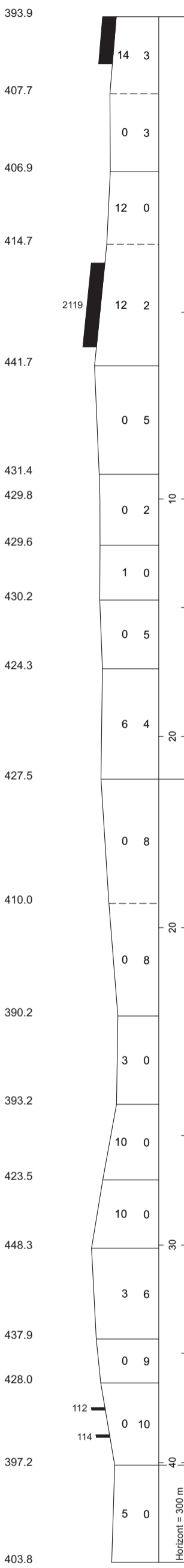

+	Zürich PB S21-24	0.00
+	Z Langstrasse	1.92
+	Z Hardbrücke v/n Altstetten	1.92
+	v/n Altstetten Hard Käferberg (Abzw)	1.35
+		3.27
+		3.08
+	Z Oerlikon	6.35
+	v/n Seebach	2.49
+	Glattbrugg Tankanlage Rümlang	8.84
+		3.34
+	Rümlang	12.18
+	Oberglatt v/n Niederweningen	2.59
+		2.12
+	Niederglatt	16.89
+		5.06
+	v/n Winterthur	
+	Bülach	21.95
+		3.14
+	Glattfelden	25.09
+		2.85
+	Eglisau v/n Koblenz	27.94
+		1.35
+	Hüntwangen-Wil	29.29
+		3.44
+	Rafz	32.73
+		3.12
+	Lottstetten	35.85
+		4.17
+	Jestetten	40.02
+		2.09
+	Altenburg-Rheinau	42.11
+	v/n Winterthur	3.70
+	Neuhausen	45.81
+		2.23
+	Schaffhausen	48.04

Höhe über Meer RPN=373.60

Längenprofil
Grösstes Gefälle
Grösste Steigung
Kilometrierung

Stationsanlage
Abzweigungen
Längste Ausweichleise

Blockstationen

Entfernung von Stat. zu Stat.
Entfernung vom Ausgangspunkt

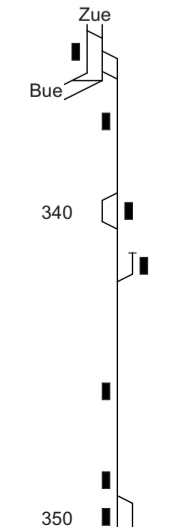
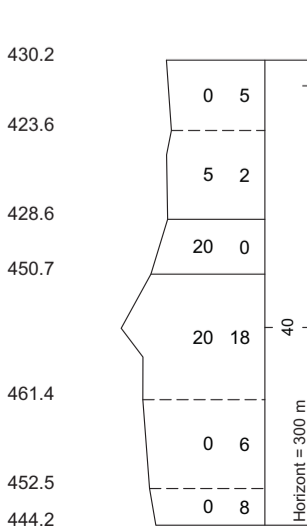

+	Oberglatt	0.00
+	Niederhasli	1.92
+		2.40
+	Dielsdorf	4.32
+	Steinmaur	1.33
+		5.65
+		2.86
+	Schöfflisdorf-Oberweningen	8.51
+		2.47
+	Niederweningen Dorf	10.98
+	Niederweningen	1.06
+		12.04

Schaffhausen
Schaffhausen W203
Herblingen
Thayngen
Bietingen
Gottmadingen
Singen (Htw.)

DB

Höhe über Meer
RPN = 373.60

Längenprofil
Grösstes Gefälle
Grösste Steigung
Kilometrierung

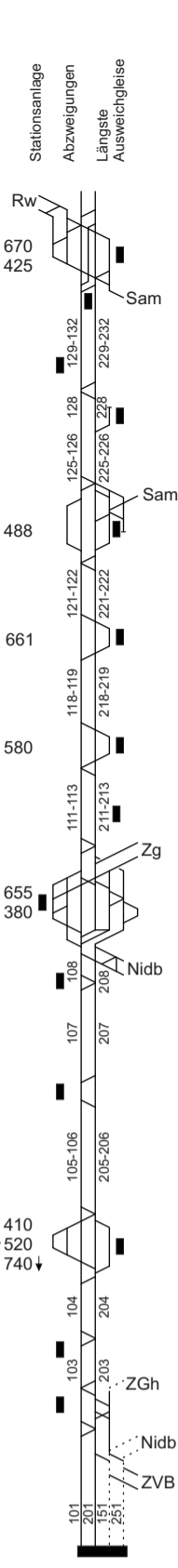
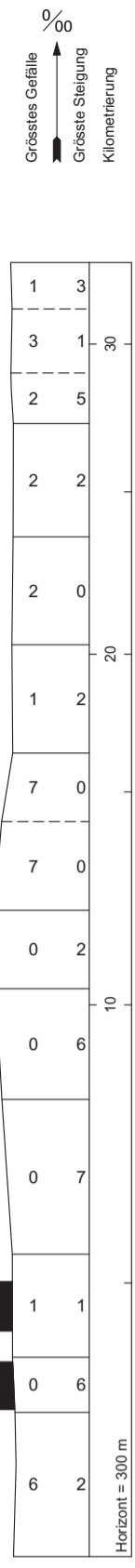

Blockstationen

Altendorf

Entfernung von Stat. zu Stat.
Entfernung vom Ausgangspunkt



I-FN-FPA-VPM
12 Dez 2010 - 10 Dez 2011 (Vers 23)
© SBB Fahrplan und Netzdesign

0-6

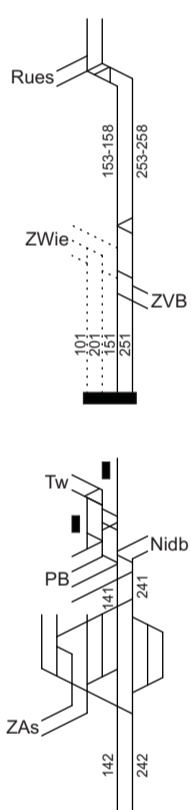

Blockstationen

Thalwil Nord (Abzw)
Nidelbad (Abzw)
Z Kollerwiese
Z Aussersihl (Abzw)
v/n Zürich VB
Zürich PB

11.67
2.27
9.40
6.26
3.14
1.45
1.69
1.69
0.00

393.9
407.7
405.0
398.9
442.0
460.5
479.0
488.0
527.0
496.8
494.0
461.0
436.0
424.0
419.0
421.0
425.0

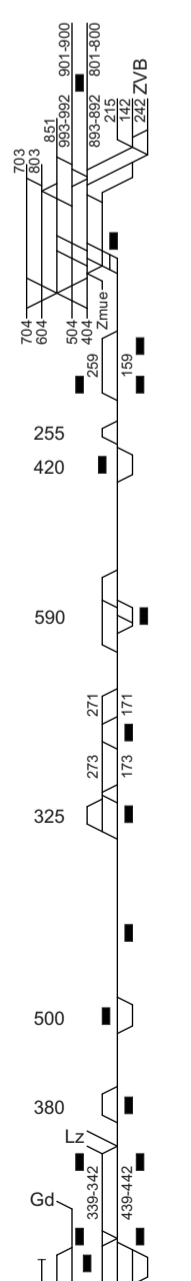
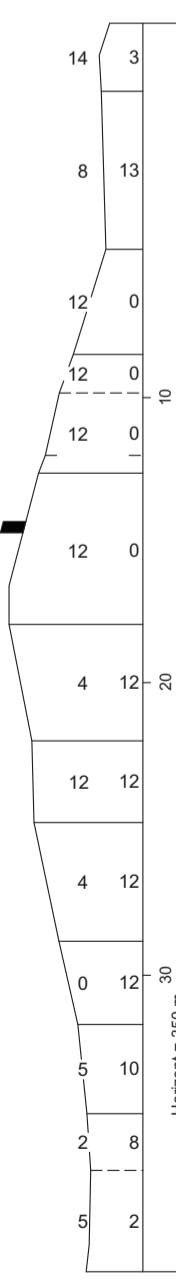

Blockstationen

Zürich PB S21-24
Z Langstrasse
Z Hardbrücke
Z Altstetten
Urdorf
Urdorf Weihermatt
Mören (Verzw)
Birmensdorf Industrie
Birmensdorf ZH
Bonstetten Nord (Verzw)
Bonstetten-W.
Bonstetten Süd (Verzw)
Hedingen Nord (Verzw)
Hedingen
Affoltern am Albis
Mettmenstetten
Knonau
Steinhausen
v/n Luzern
Kollermühle (Abzw)
Zug Chollermüli
v/n Goldau
Zug Schutzengel
Zug
v/n Thalwil
Baar Lindenpark

0.00
1.90
1.90
2.20
4.10
4.41
8.51
1.33
9.84
2.17
0.64
12.01
12.65
4.64
0.70
17.29
17.99
0.96
18.95
1.86
20.81
1.23
22.04
2.73
24.77
4.07
28.84
2.82
31.66
3.00
34.66
1.63
36.29
0.23
36.52
1.72
38.24
0.65
38.89



SBB 64

I-FN-FPA-VPM

12 Dez 2010 - 10 Dez 2011 (Vers 23)

© SBB Fahrplan und Netzdesign

0-12

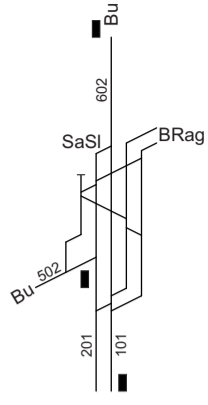
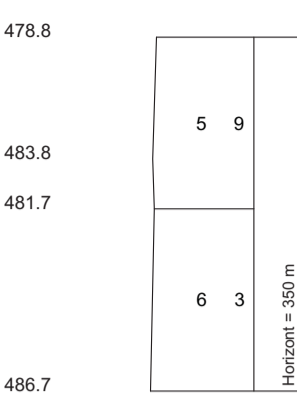

+ Trübbach	
v/n Buchs SG	
+ Sargans Schleife (Verzw)	5.60
+ Sargans	
	2.34
+ Mels	

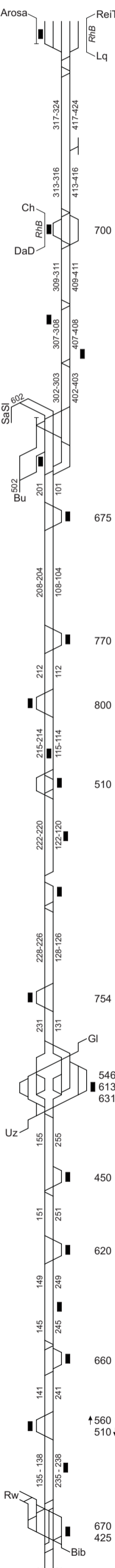
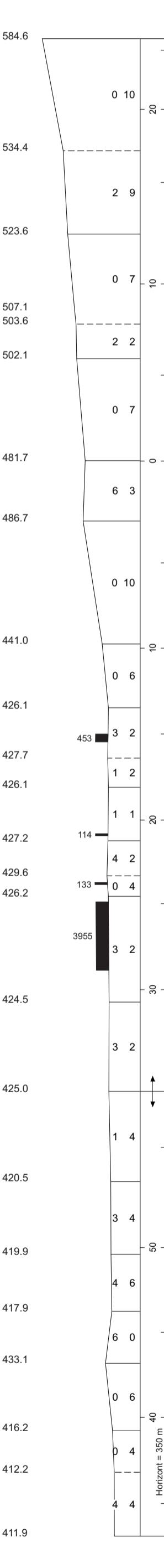

Chur West	
v/n Reichenau-Tamins	
Chur GB	
Chur	
Chur GB	116.55
Chur	0.50
	116.05
	9.41
Zizers SBB Cement (Agl)	106.64
	4.00
v/n Chur RhB	
Landquart	102.64
v/n Davos	
	4.53
Rosriet (Spw)	
Maienfeld	98.11
	2.03
Bad Ragaz	96.08
	5.95
Sargans	90.13
v/n Buchs SG	
	2.34
Mels	87.79
	7.18
Flums	80.61
	3.75
Walenstadt	76.86
	2.90
Mols	73.96
Unterterzen	72.23
	1.73
Murg	69.12
	3.11
Tiefenwinkel (Verzw)	2.04
Mühlehorn	67.08
	1.28
	65.80
	6.11
Weesen	59.69
	2.89
v/n Glarus	
Ziegelbrücke	56.80
v/n Uznach	
	2.92
Bilten	53.88
	4.29
Reichenburg	49.59
	3.37
Schübelbach-B.	46.22
	3.09
Siebnen-Wangen	43.13
	3.90
Lachen	39.23
	2.41
Altendorf	36.82
	3.74
Pfäffikon SZ	33.08
v/n Zürich	
Freienbach SBB	
Rapperswil	
Hurden SOB	
Pfäffikon SZ Nord (Abzw)	
Pfäffikon SZ	
v/n Samstagern	
Freienbach SOB	

Höhe über Meer RPN = 373.60
 Längenprofil
 Grösstes Gefälle
 Grösste Steigung
 Kilometrierung
 Stationsanlage
 Abzweigungen
 Längste Auswechgleise
 Blockstationen
 Entfernung von Stat. zu Stat.
 Entfernung vom Ausgangspunkt



I-FN-FPA-VPM

12 Dez 2010 - 10 Dez 2011
(Vers 23)

© SBB Fahrplan und Netzdesign

0-12

Pfäffikon SZ

Pfäffikon Nord (Abzw)
Hurden SOB

Rapperswil

v/n Uznach

Blumenau

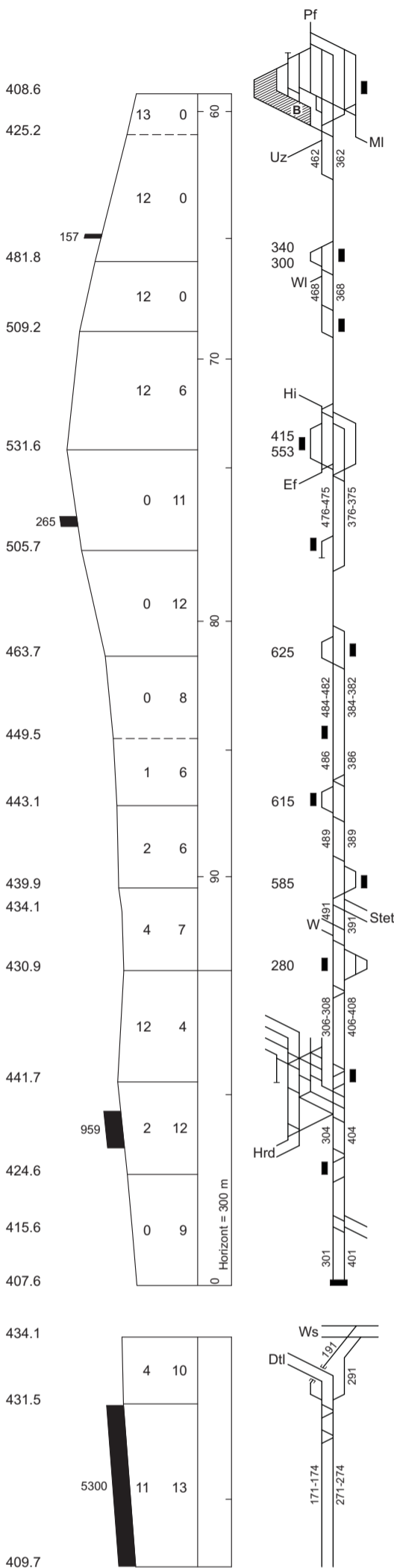

Rapperswil	42.84
Jona	1.60
Grünfels (Verzw)	41.24
4.99	
Rüti ZH	36.25
v/n Wald	2.72
Bubikon	33.53
5.86	
v/n Hinwil	
Wetzikon	27.67
v/n Effretikon	2.76
Aathal	24.91
4.08	
Uster	20.83
3.21	
Nänikon-Greifensee	17.62
2.60	
Schwerzenbach ZH	15.02
3.28	
Dübendorf	11.74
Chriesbach (Abzw)	0.81
10.93	
1.98	
Wallisellen	8.95
3.64	
Z Oerlikon	5.31
2.42	
Z Wipkingen	2.89
1.49	
Z Viadukt (Abzw)	1.40
1.40	
Zürich PB A 3-18	0.00
Q 51-54	

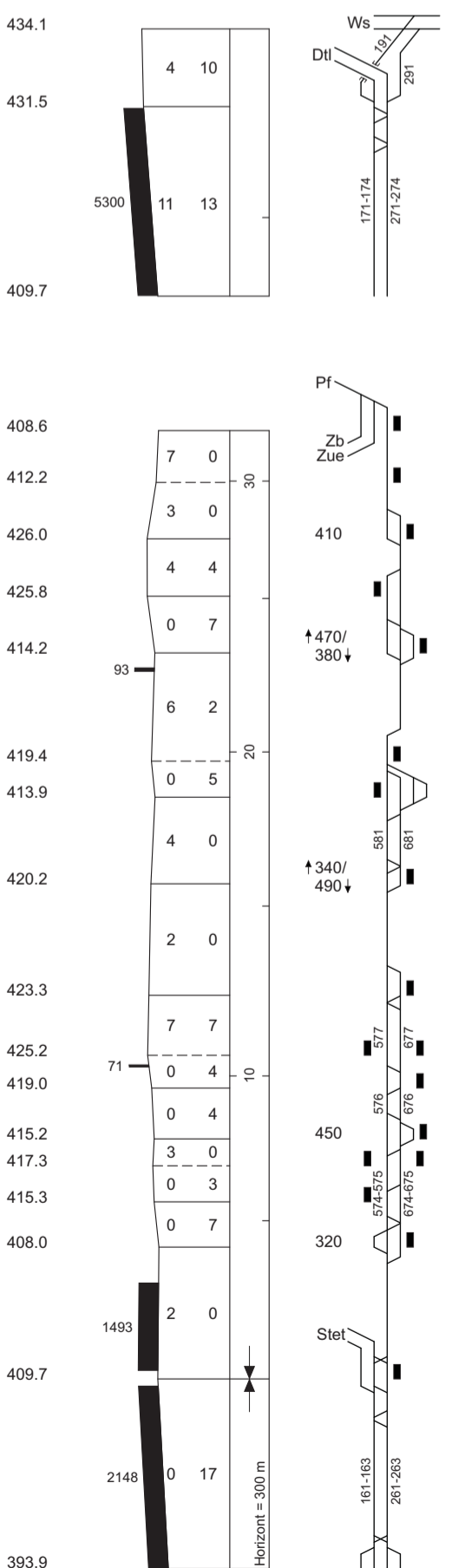

Chriesbach (Abzw)	1.88
Stettbach	5.35
Z Stadelhofen	
Rapperswil	32.07
Kempraten	2.14
29.93	
Feldbach	2.43
27.50	
Uerikon	2.43
25.07	
Stäfa	2.49
22.58	
2.83	
Männedorf	19.75
Uetikon	1.23
18.52	
2.96	
Meilen	15.56
2.85	
Herrliberg-F.	12.71
2.03	
Winkel am Zürichsee	10.68
Erlenbach ZH	1.11
9.57	
1.74	
Küssnacht ZH	7.83
Küssnacht Goldbach	0.93
6.90	
Zollikon	1.27
5.63	
Z Tiefenbrunnen	1.59
4.04	
2.24	
v/n Stettbach	
Z Stadelhofen	1.80
1.80	
Zürich PB S21-24	0.00

Höhe über Meer
MPN = 373.60
RPN = 373.60

Längenprofil
Grösstes Gefälle
Grösste Steigung
Kilometrierung

Stationsanlage
Abzweigungen
Längste Ausweicheise

Blockstationen

v/n Hardbrücke

Entfernung von Stat. zu Stat.
Entfernung vom Ausgangspunkt



SBB 66

I-FN-FPA-VPM

12 Dez 2010 - 10 Dez 2011 (Vers 23)

© SBB Fahrplan und Netzdesign

Bubikon

0-12

v/n Rapperswil
Wetzikon

v/n Uster

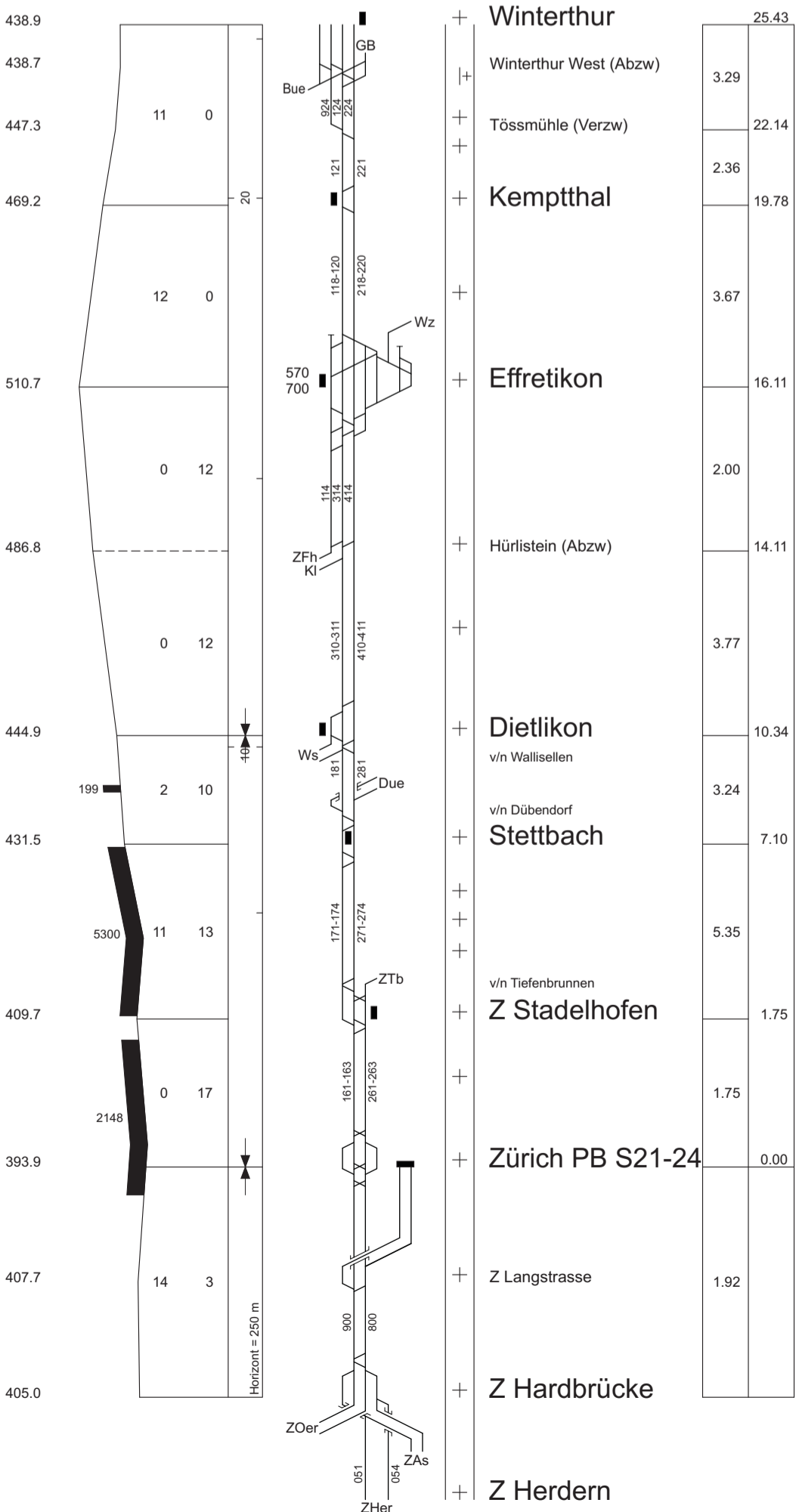
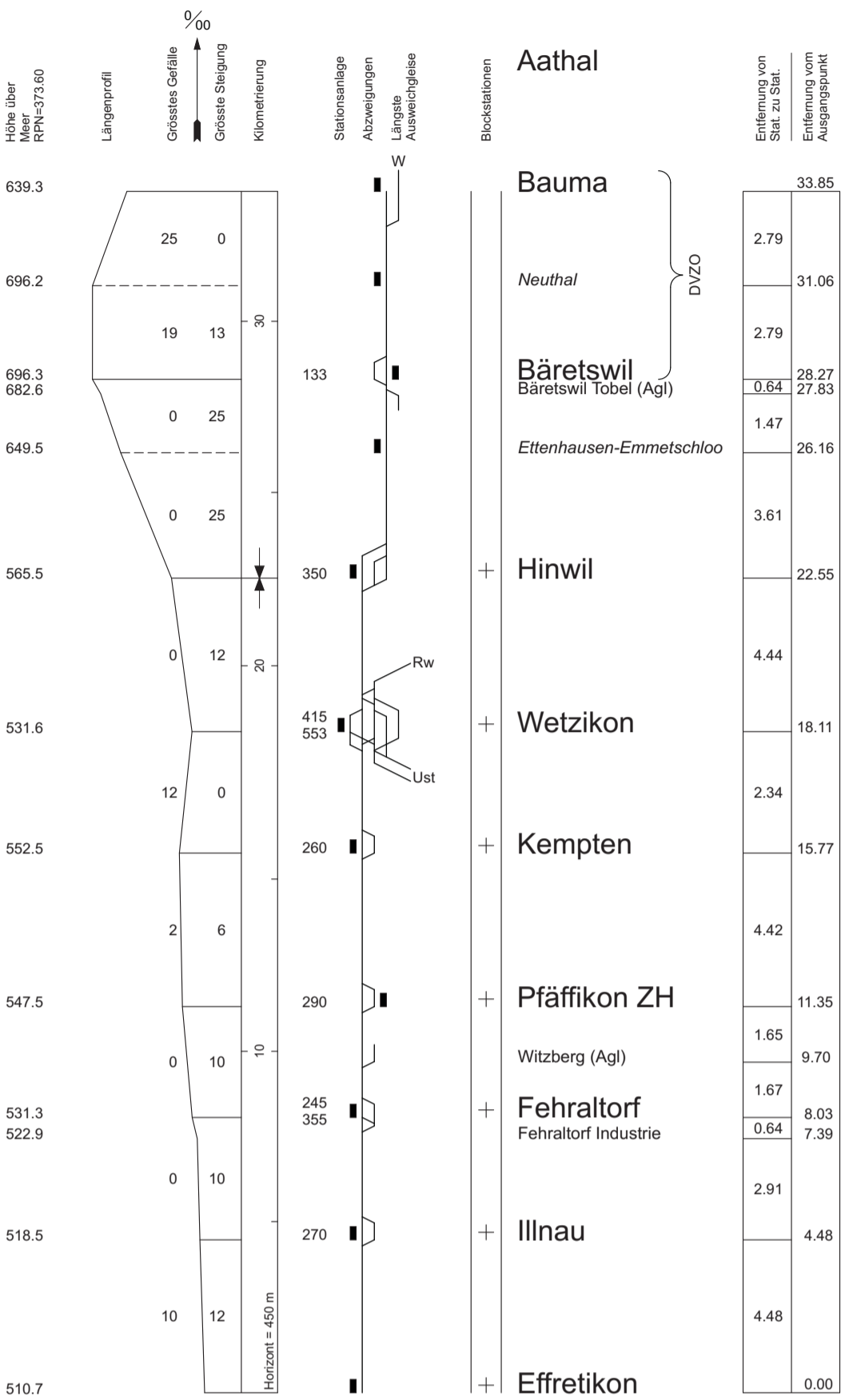



SBB 70 A

I-FN-FPA-VPM

12 Dez 2010 - 10 Dez 2011

(Vers 23)

© SBB Fahrplan und Netzdesign

0-6

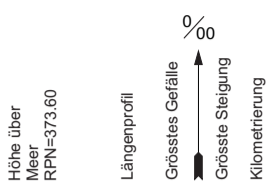

Stationsanlage

Abzweigungen

Längste

Ausweichleise

Blockstationen

Entfernung von Stat. zu Stat.

Entfernung vom Ausgangspunkt

Winterthur

Gl. 46

Winterthur West (Abzw)

Winterthur GB

Winterthur West (Abzw)

Winterthur Grüze

v/n St. Gallen Bauma

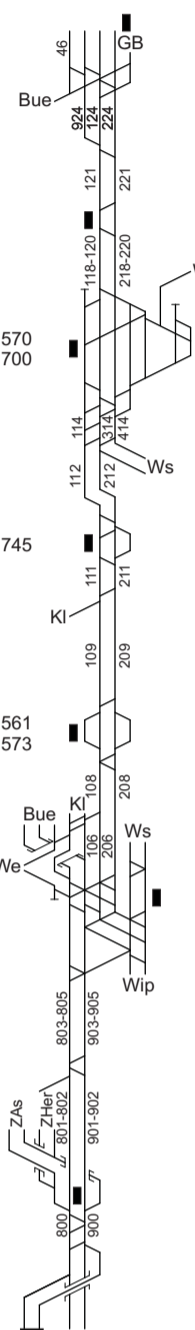
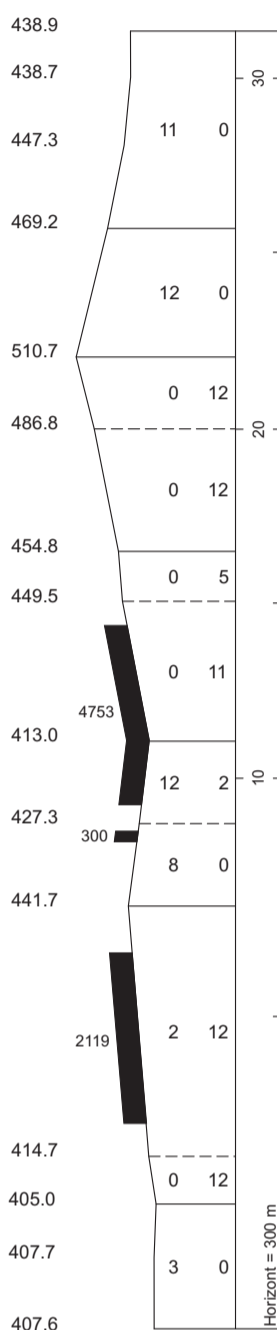

+	Winterthur	31.33
+	Gl. 45 / 44 / 43	
+	Winterthur West (Abzw)	3.29
+	Tössmühle (Verzw)	28.04
+		2.36
+	Kemptthal	25.68
+		3.67
+	Effretikon	22.01
+		2.00
+	Hürlistein (Abzw)	20.01
+		3.47
+	Bassersdorf	16.54
+		1.49
+	Dorfneft (Abzw)	15.05
+		3.94
+	Z Flughafen	11.11
+		2.31
+	Opfikon	8.80
+	Opfikon Süd (Abzw)	0.67 8.13
+	Z Oerlikon	1.78 6.35
+		3.08
+		
+	Hard Käferberg (Abzw)	3.27
+	Z Hardbrücke	1.35 1.92
+		1.00 0.92
+	Z Langstrasse	0.92 0.00
+	Zürich PB A3-18	

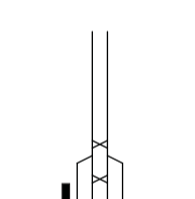
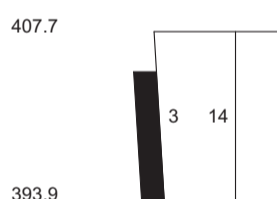

+	Z Langstrasse	0.92
+	Zürich PB S21-24	

Illnau

v/n Wetzikon

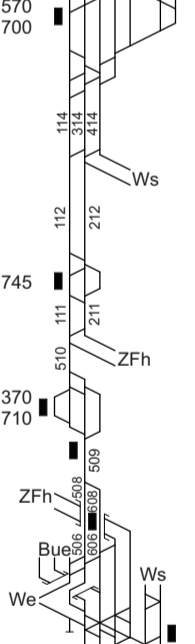
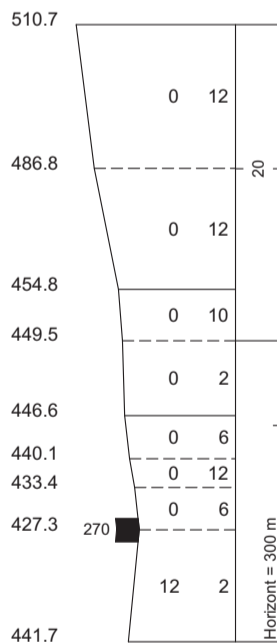

+	Effretikon	22.01
+		2.00
+	Hürlistein (Abzw)	20.01
+		3.47
+	Bassersdorf	16.54
+		1.49
+	Dorfneft (Abzw)	7.38
+		2.12
+	Kloten	5.26
+	Kloten Balsberg	1.21 4.05
+	Riet (Verzw)	0.62 3.43
+		0.98 2.45
+	Opfikon	0.67 1.78
+	Opfikon Süd (Abzw)	1.78
+	v/n Seebach	
+	Z Oerlikon	0.00

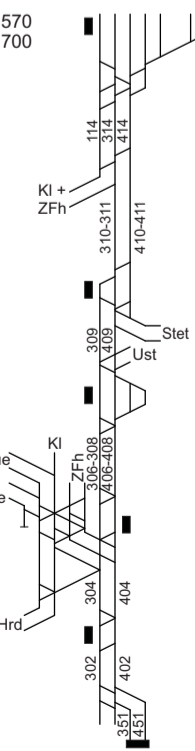
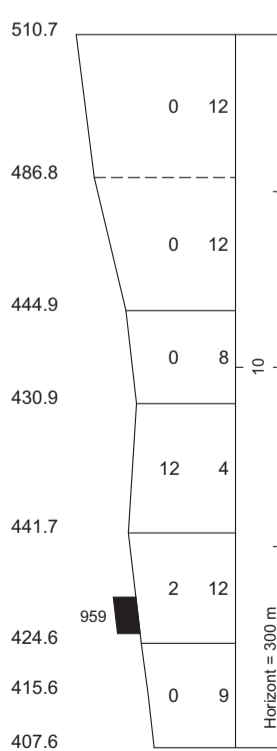

+	Effretikon	17.40
+		2.00
+	Hürlistein (Abzw)	15.40
+		3.77
+	Dietlikon	11.63
+	v/n Stettbach	
+		2.68
+	v/n Uster	
+	Wallisellen	8.95
+		3.64
+	Z Oerlikon	5.31
+		2.42
+	Z Wipkingen	2.89
+		1.49 1.40
+	Z Viadukt (Abzw)	1.40 0.00
+	Gl. 351 / 451	
+	Zürich PB A3-18	
+	Q51-54	

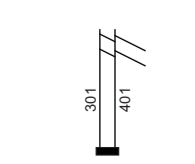
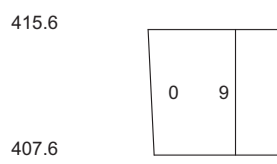

+	Z Viadukt (Abzw)	1.40
+	Gl. 301/401	
+	Zürich PB A3-18	
+	Q51-54	

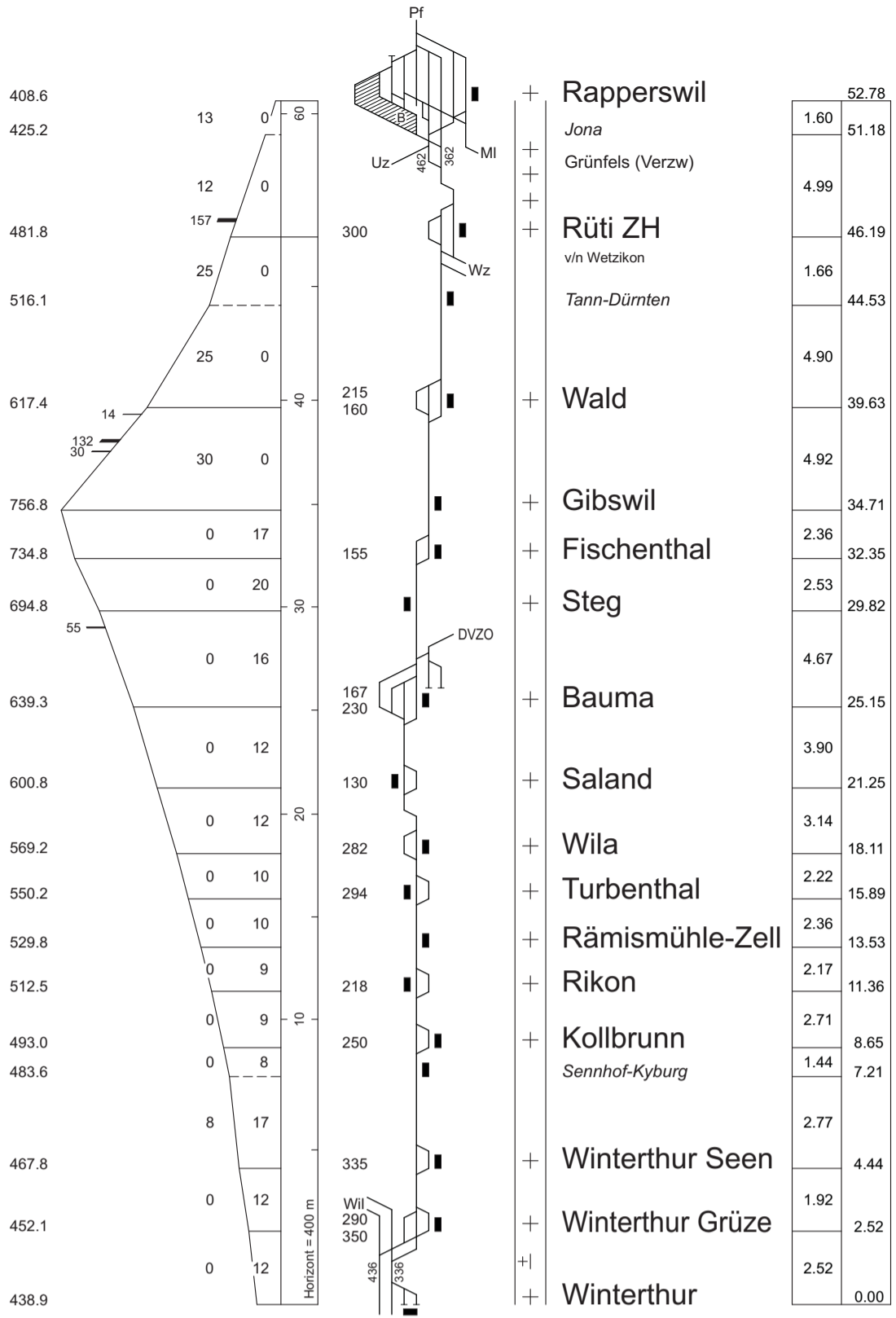

SBB 71 St. Gallen GB

I-FN-FPA-VPM
12 Dez 2010 - 10 Dez 2011 (Vers 23)
 © SBB Fahrplan und Netzdesign

0-12

St. Gallen West
 SG St. Fiden

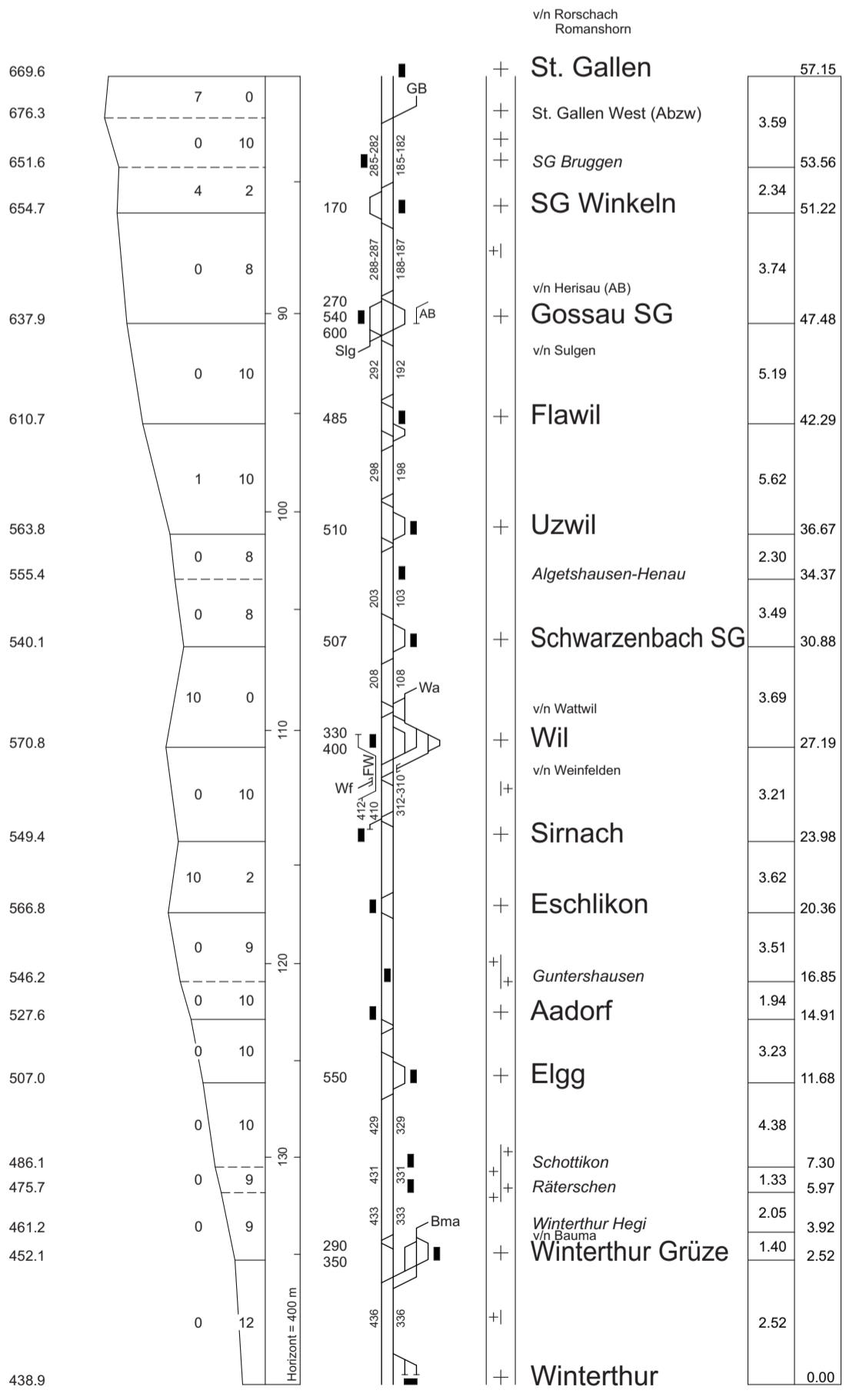

Höhe über Meer RPN=373.60

Längenprofil

Grösstes Gefälle

Grösste Steigung

Kilometerung

Stationenanlage

Abzweigungen

Längste Ausweichleise

Blockstationen

Entfernung von Stat. zu Stat.

Entfernung vom Ausgangspunkt

Winterthur West

Winterthur

Winterthur GB



SBB

72

I-FN-FPA-VPM

12 Dez 2010 - 10 Dez 2011 (Vers 23)

© SBB Fahrplan und Netzdesign

0-12

481.6
483.8
478.8

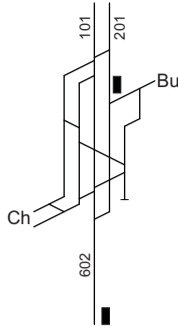
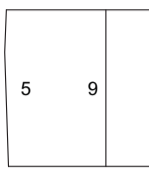

Mels

v/n Ziegelbrücke

Sargans

Sargans Schleife (Verzw)

Trübbach

5.60

481.6
478.8
470.1
468.8
458.2
451.5
447.2
440.9
436.3
425.9
420.7
429.7
409.8
405.6
405.0
402.1
399.9
400.0
402.1
399.0
413.2
447.3
497.2
542.4
583.7
645.5
1466
669.6

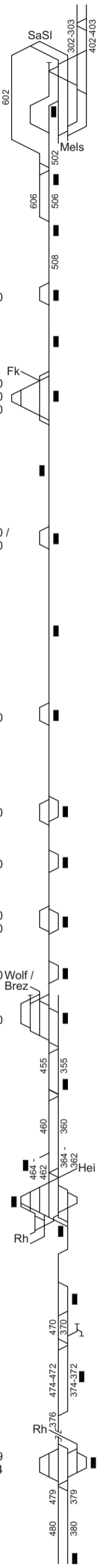
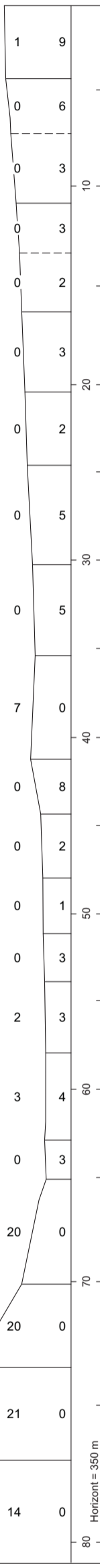

Bad Ragaz

Sargans

Trübbach

Neugrüt (Verzw)

Weite

Sevelen

Räfis-Burgerau

v/n Feldkirch

Buchs SG

Haag-Gams

Salez-Sennwald

Rüthi SG

Oberriet

Altstätten SG

Rebstein-Marbach

Heerbrugg

Au SG

v/n Bregenz / Wolfurt

St. Margrethen

Rheineck

Altenrhein (Agl)

Staad

v/n Heiden

Rorschach

Rorschach Stadt

Goldach Ost (Verzw)

Goldach

Horchtal

Mörschwil

Engwil (Verzw)

v/n Romanshorn

SG St. Fiden

St. Gallen

v/n Gossau SG

St. Gallen West (Abzw)

Rorschach

Rorschach Hafen

Horn

Steinach

Arbon

Arbon Seemoosriet

Egnach

Romanshorn Süd (Abzw)

Romanshorn

Romanshorn Süd (Abzw)

Romanshorn GB

Romanshorn

80.23
4.10
76.13
2.28
73.85
0.46
73.39
3.90
69.49
2.82
66.67
2.10
64.57
4.52
60.05
4.19
55.86
5.65
50.21
5.10
45.11
5.86
39.25
3.11
36.14
3.64
32.50
3.12
29.38
2.77
26.61
4.01
22.60
3.95
18.65
1.01
17.64
2.25
15.39
1.23
14.16
0.80
13.36
0.90
12.46
2.46
10.00
2.33
7.67
2.09
5.58
3.24
2.34
2.34
0.00

Höhe über Meer
RFN=373.60

Längenprofil

Grösstes Gefälle
Grösste Steigung
Kilometrierung

Stationsanlage
Abzweigungen
Längste Ausweichleise

Blockstationen

Entfernung von Stat. zu Stat.
Entfernung vom Ausgangspunkt



SBB 73

I-FN-FPA-VPM

12 Dez 2010 - 10 Dez 2011 (Vers 23)

© SBB Fahrplan und Netzdesign

0-12

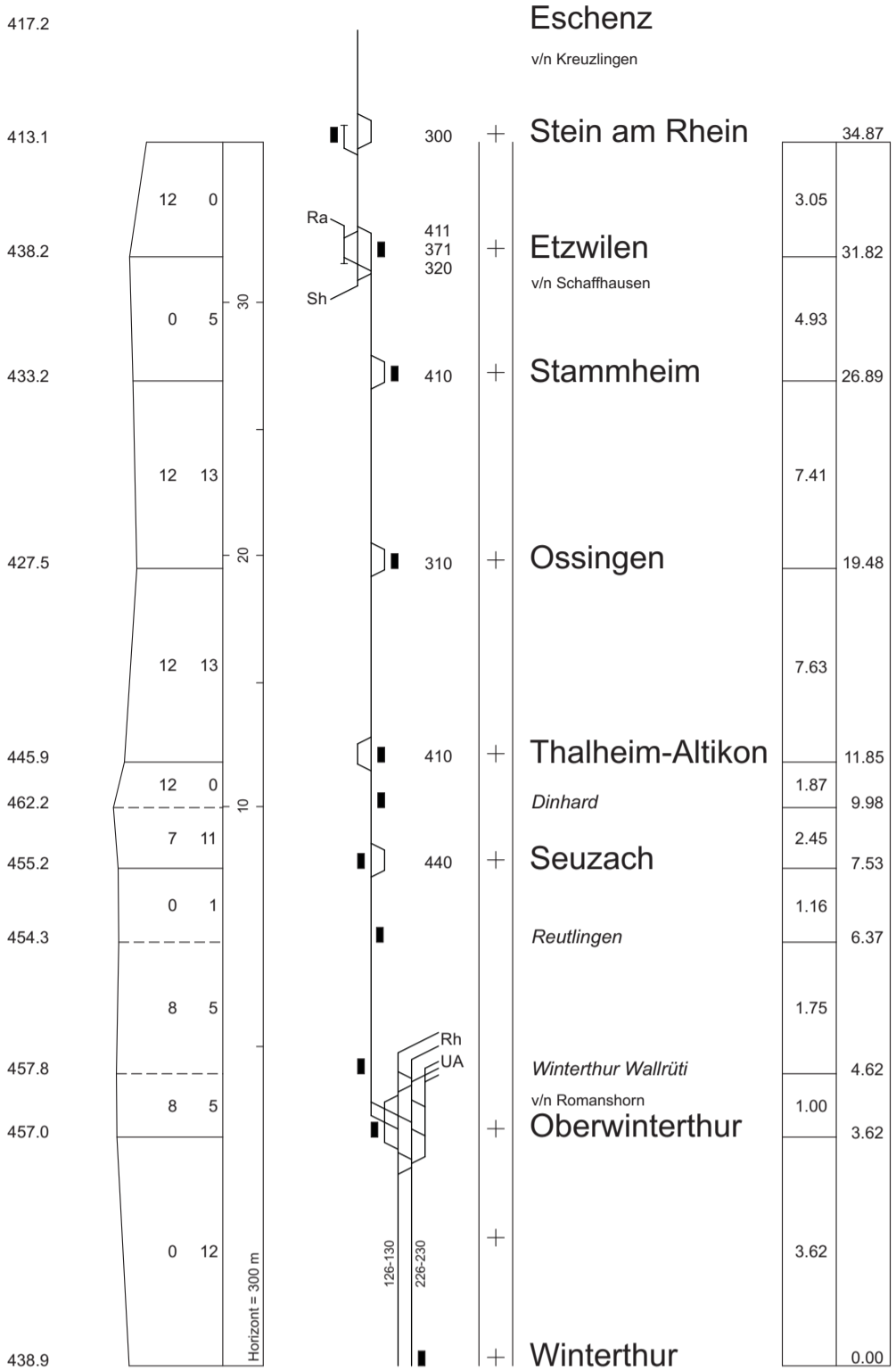

Winterthur GB

Schaffhausen GB

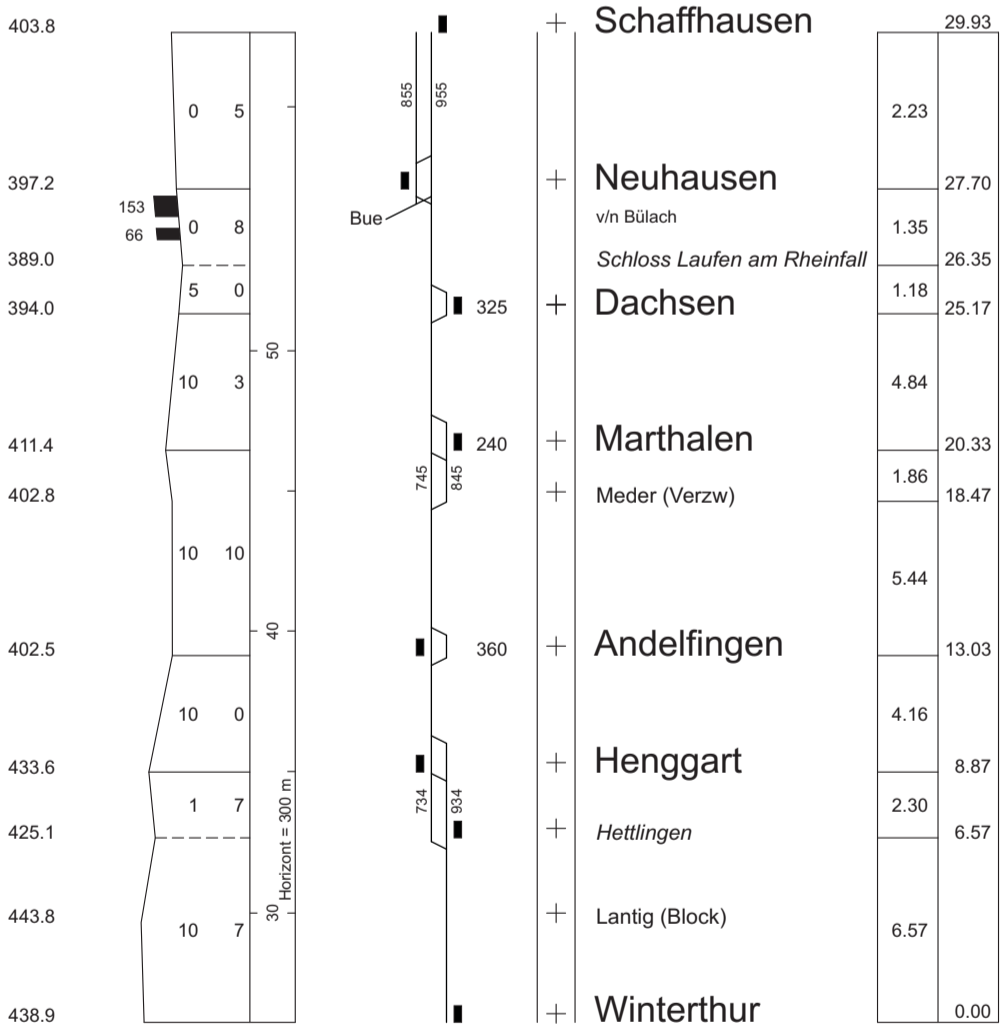

Winterthur GB

Höhe über Meer
RPN=373.60

Längenprofil

Grösstes Gefälle

Grösste Steigung

Kilometrierung

Stationsanlage

Abzweigungen

Längste Ausweichleise

Entfernung von Stat. zu Stat.

Entfernung vom Ausgangspunkt



SBB 74

I-FN-FPA-VPM

12 Dez 2010 - 10 Dez 2011 (Vers 23)

© SBB Fahrplan und Netzdesign

St. Gallen GB

0-12

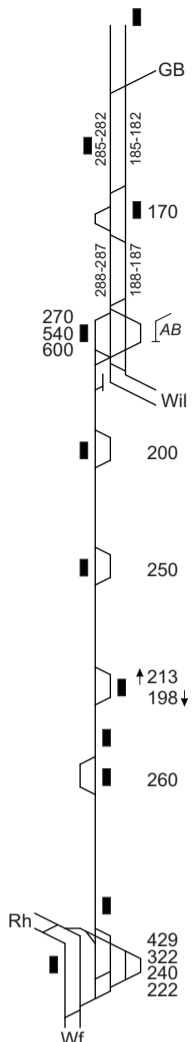
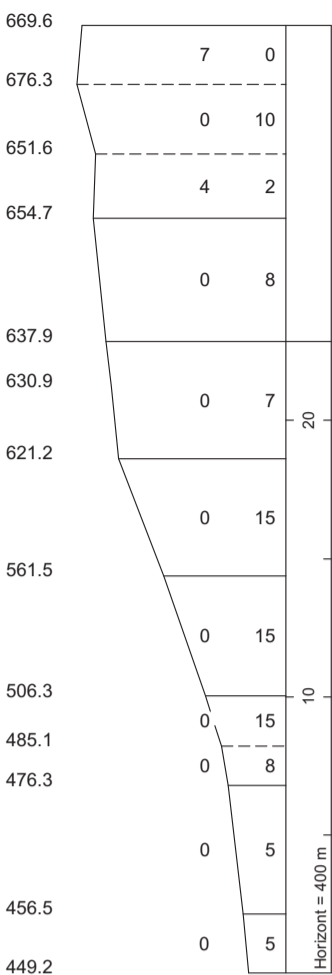

St. Gallen West (Abzw)

St. Gallen

St. Gallen West (Abzw)

St. Gallen Bruggen

SG Winkeln

Gossau SG

Gossau Sommerau (Agl)

Arnegg

Hauptwil

Bischofszell Stadt

Sitterdorf

Bischofszell Nord

Kradolf

Sulgen

	32.62
1.05	31.57
2.54	29.03
2.34	26.69
3.74	
4.36	22.95
4.21	18.59
4.21	
4.33	
1.85	10.05
1.42	8.20
1.42	6.78
4.66	
2.12	2.12
2.12	0.00

Romanshorn Süd (Abzw)

v/n Rorschach

Romanshorn

Uttwil

Romanshorn Süd (Abzw)

Romanshorn VL

Romanshorn West (Abzw)

Romanshorn

Romanshorn West (Abzw)

Amriswil

Oberaach

Erlen

v/n Gossau

Sulgen

Bürglen

Weinfelden KVA TG (Agl)

v/n Konstanz

Weinfelden

v/n Wül

Märstetten

Müllheim-Wigoltingen

Hüttlingen-Mettendorf

Felben-Wellhausen

v/n Frauenfeld Paketpost

Frauenfeld

Islikon

Rickenbach-Attikon

Wiesendangen

v/n Etzwilen

Oberwinterthur

Winterthur

v/n Zürich

Winterthur West (Abzw)

Unterhaltsanlage

Oberwinterthur

Winterthur

Winterthur GB

	56.12
6.57	
49.55	
2.67	46.88
3.21	43.67
3.60	
40.07	
2.83	37.24
1.99	35.25
1.80	33.45
3.80	
29.65	
3.57	26.08
3.45	
22.63	
2.47	20.16
4.14	
16.02	
4.00	
12.02	
4.52	
7.50	
1.61	5.89
2.27	3.62
3.62	
0.00	

Höhe über Meer
RPN=373.60

Längenprofil

Grösstes Gefälle

Grösste Steigung

Kilometrierung

Stationsanlage

Abzweigungen

Längste Ausweichgleise

Blockstationen

Entfernung von Stat. zu Stat.

Entfernung vom Ausgangspunkt



SBB

75

I-FN-FPA-VPM

12 Dez 2010 - 10 Dez 2011
(Vers 23)

© SBB Fahrplan und Netzdesign

0-12

Schwarzenbach SG

v/n St. Gallen

Wil

v/n Winterthur

Sirnach

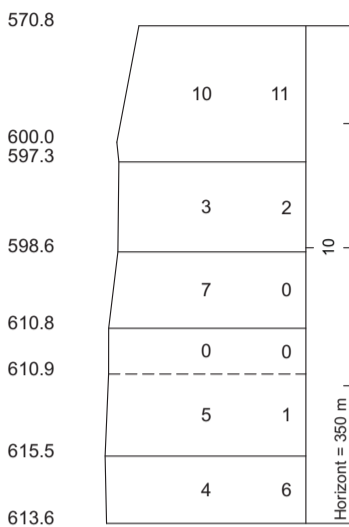

Wil	20.00
Bazenheid ZAB (Agl)	5.90
Bazenheid	1.02 14.10 13.08
Lütisburg	3.23 9.85
Bütschwil	2.77 7.08
<i>Dietfurt</i>	1.69 5.39
Lichtensteig	2.90 2.49
Wattwil	2.49 0.00
v/n Nesslau	
Ebnat-Kappel	

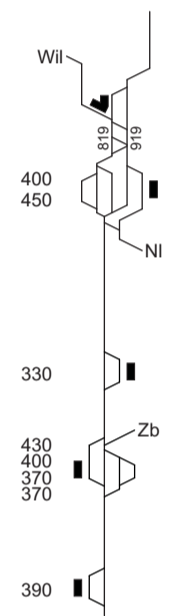
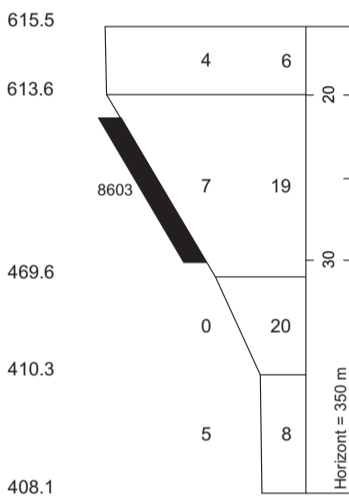

Brunnadern-Neckertal	
v/n St. Gallen	
Lichtensteig	
Wattwil	27.18
	10.98
Kaltbrunn	16.20
v/n Ziegelbrücke	
Uznach	3.40 12.80
	2.83
Schmerikon	9.97

Weesen

v/n Sargans

Ziegelbrücke

v/n Zürich

Höhe über Meer
RPN=373.60

Längenprofil

Grösstes Gefälle

Grösste Steigung

Kilometrierung

Stationsanlage

Abzweigungen

Längste Ausweichleise

Blockstationen

Bilten

Entfernung von Stat. zu Stat.

Entfernung vom Ausgangspunkt

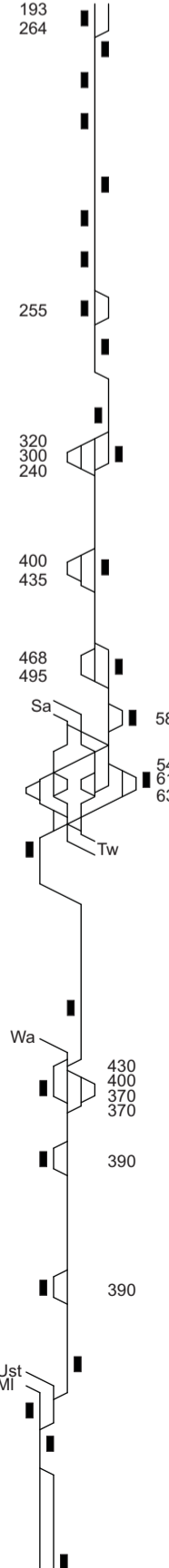
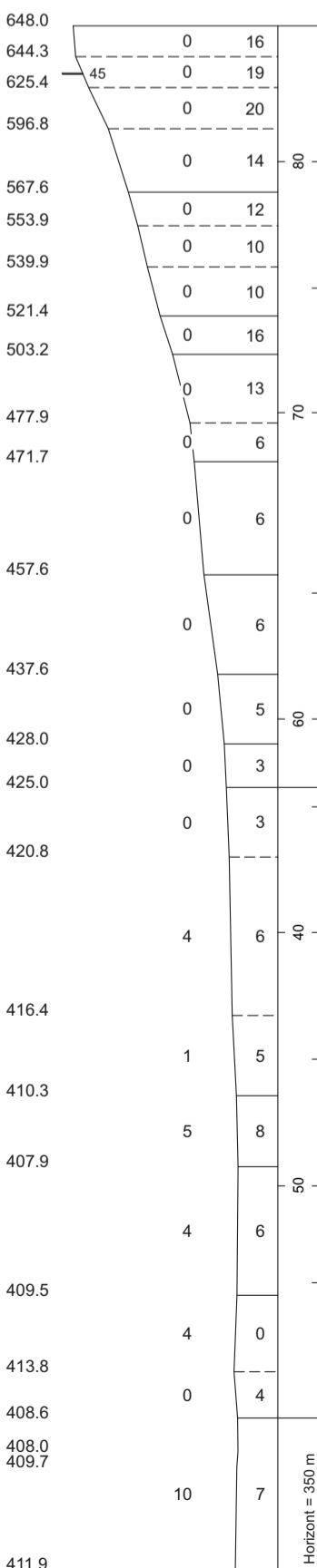

Linthal	52.28
<i>Linthal Braunwaldbahn</i>	0.40 51.88
<i>Rüti GL</i>	1.20 50.68
<i>Diesbach-Betschwanden</i>	1.60 49.08
Luchsingen-Hätzingen	2.57 46.51
<i>Leuggelbach</i>	1.31 45.20
<i>Nidfurn-Haslen</i>	1.60 43.60
Schwanden	1.96 41.64
Mitlödi	1.55 40.09
	2.78
<i>Ennenda</i>	37.31
Glarus	0.88 36.43
	2.97
Netstal	33.46
	3.98
Näfels-Mollis	29.48
	2.74
Nieder- und Oberurnen	26.74
Ziegelbrücke	1.76 24.98
	2.77
<i>Schänis</i>	22.21
	6.29
<i>Benken</i>	15.92
v/n Wattwil	
Uznach	3.12 12.80
Schmerikon	2.83 9.97
	5.09
Bollingen	4.88
	3.01
<i>Blumenau</i>	1.87
Rapperswil	1.87 0.00
<i>Hurden</i>	
<i>Pfäffikon SZ Nord (Verzw)</i>	4.05
Pfäffikon SZ	



SBB 76

I-FN-FPA-VPM

12 Dez 2010 - 10 Dez 2011
(Vers 23)

© SBB Fahrplan und Netzdesign

0-12

Weinfelden KVA TG

v/n Romanshorn

Weinfelden

v/n Winterthur

Märstetten

Kurzrickenbach Seepark

v/n Romanshorn

Kreuzlingen Hafen

Kreuzlingen

Kreuzlingen Hafen
Kreuzlingen Hafen Grenze

Konstanz

Singen (Htw)

Radolfzell

DB

Konstanz

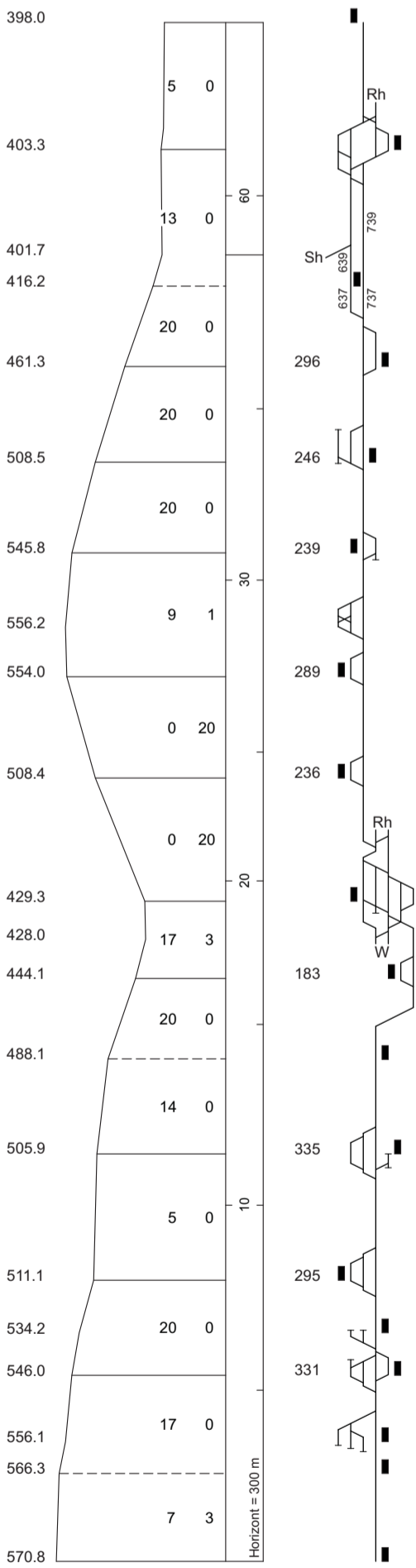

+	Konstanz	42.31
		0.50
+	Kreuzlingen Grenze	41.81
	Kreuzlingen	0.67
		41.14
		1.54
+	Tägermoos (Abzw)	39.60
	Tägerwilen Dorf	0.97
		38.63
+	Kreuzlingen Bernrain	2.38
		36.25
		2.79
+	Lengwil	33.46
		2.68
+	Siegershausen	30.78
	Altishausen (Agl)	2.13
		28.65
+	Berg	1.42
		27.23
		2.92
+	Kehlhof	24.31
		5.14
+	Weinfelden	19.17
	Weinfelden Süd (Agl)	1.60
		17.57
+	Bussnang	1.22
		16.35
	Oppikon	2.31
		14.04
		2.79
+	Märwil	11.25
		3.03
+	Tobel-Affeltrangen	8.22
	Tägerschen	1.51
		6.71
+	Bettwiesen	1.26
		5.45
		1.94
+	Bronschhofen AMP	3.51
	Bronschhofen	0.93
		2.58
		2.58
+	Wil	0.00

v/n Wattwil

Bazenheid

Höhe über Meer
RPN=373.60

Längenprofil

Grösstes Gefälle
Grösste Steigung

0/00

Stationsanlage
Abzweigungen
Längste Ausweicheise

Blockstationen

Entfernung von Stat. zu Stat.
Entfernung vom Ausgangspunkt

Sirnach

v/n Winterthur

Wil

v/n St. Gallen

Schwarzenbach SG

I-FN-FPA-VPM
12 Dez 2010 - 10 Dez 2011
(Vers 23)

© SBB Fahrplan und Netzdesign

0-12

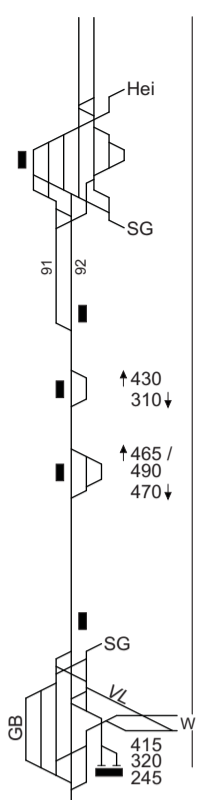
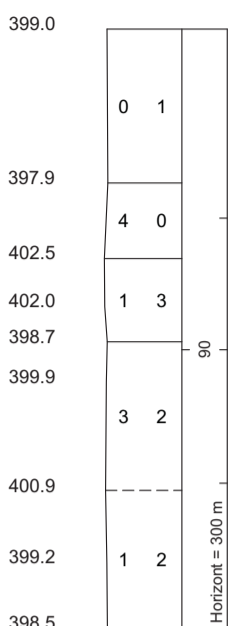

Staad	v/n Buchs SG		
	v/n Heiden	2.25	
Rorschach		0.95	80.07
Rorschach Hafen			79.12
		2.85	
Horn			76.27
	<i>Steinach</i>	1.82	74.45
Arbon		1.36	73.09
	<i>Arbon Seemoosriet</i>	1.54	71.55
		4.03	
	<i>Egnach</i>		67.52
	Romanshorn Süd (Abzw)	2.57	
Romanshorn			64.95

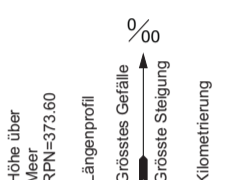

Stationsanlage
 Abzweigungen
 Längste Ausweichgleise

Neukirch-Egnach	v/n St. Gallen		
	Romanshorn Süd (Abzw)		
Romanshorn			
	Romanshorn Süd (Abzw)		

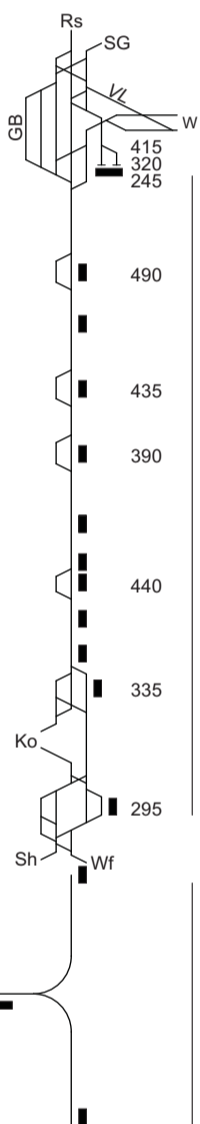
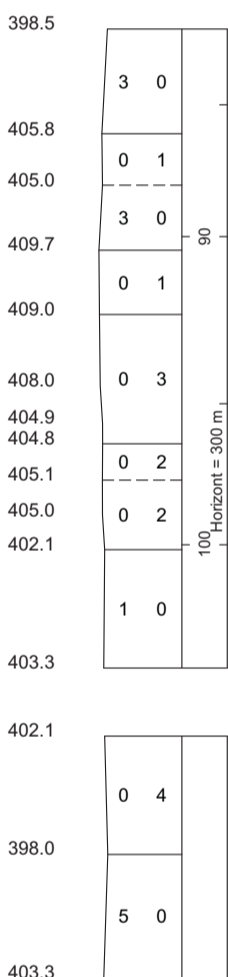

Romanshorn GB	v/n VL		
Romanshorn			64.95
	v/n Amriswil	3.96	
Uttwil		1.98	60.99
	<i>Kesswil</i>		59.01
		2.40	
Güttingen			56.61
		2.43	
Altnau			54.18
	<i>Landschlacht</i>	1.63	
	<i>Münsterlingen Spital</i>	0.89	52.55
	Münsterlingen-Sch.	0.73	51.66
	<i>Bottighofen</i>	1.35	50.93
	<i>Kurzriekenbach Seepark</i>	1.33	49.58
Kreuzlingen Hafen		1.33	48.25
	v/n Konstanz		46.92
		1.11	
Kreuzlingen			45.81
	Kreuzlingen Hafen	0.47	2.27
	Kreuzlingen Hafen Grenze		1.80
		0.63	
	Konstanz	0.50	1.17
	Kreuzlingen Grenze		0.67
		0.67	
Kreuzlingen	Tägermoos (Abzw)		0.00
	<i>Tägerwilen Dorf</i>		
	v/n Weinfelden		

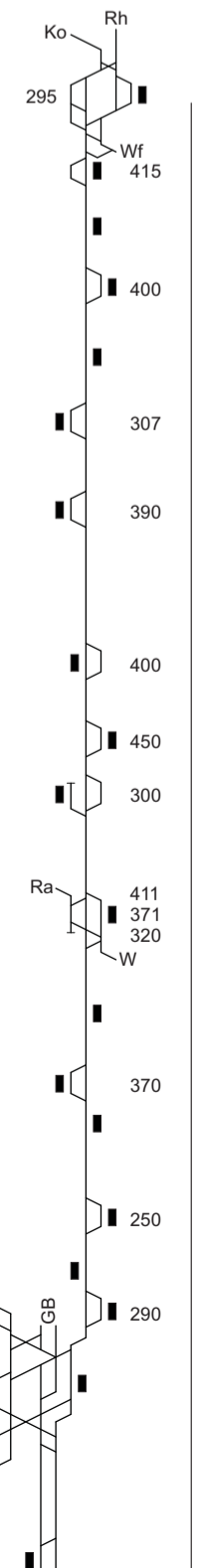
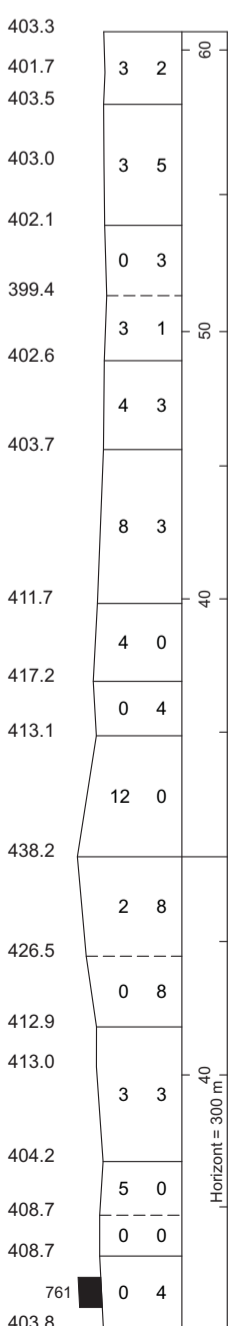

Kreuzlingen			45.81
	Tägermoos (Abzw)	1.54	44.27
	Tägerwilen-G.	1.29	42.98
	<i>Triboltingen</i>	1.88	41.10
	Ermatingen	1.97	39.12
	<i>Mannenbach-Salenstein</i>	2.68	36.45
		2.41	
Berlingen			34.04
		3.32	
Steckborn			30.72
		5.76	
Mammern			24.96
		2.91	
Eschenz			22.05
Stein am Rhein		2.07	19.98
		3.05	
Etzwilen			16.93
	v/n Winterthur	3.76	
	<i>Schlattingen</i>		13.17
		2.61	
Diessenhofen			10.56
	<i>St. Katharimental</i>	1.55	9.01
		3.54	
Schlatt			5.47
	<i>Langwiesen</i>	2.07	3.41
Feuerthalen		1.57	1.83
		1.83	
Schaffhausen			0.00
	v/n Bülach		
	v/n Winterthur	2.23	
Neuhausen			