

Fahrpläne Basel Nord Sued ab 18.03.2013

Stunden: 0 - 3

DB Netz

Niederlassung Südwest

Jahresfahrplan 2013 vom: 09. Dezember 2012 bis: 14. Dezember 2013  
Gültig vom: 18. März 2013 bis: 08. Juni 2013 / täglich

Fahrpläne Basel Nord Sued ab 18.03.2013

Stunden: 0 - 3

Basel Bad Bf Basel SBB Pb	
GWB	
PZB	
Hauptbahn	
70 <110 >	
4404	
1.8	
5.1	3.5

BAV 520

Basel Bad Bf Basel SBB Rb	
PZB	
Hauptbahn	
60	
4405	
0.9	
0.9	0.0

BAV 508 / 1

Basel Bad Bf Basel Rbf(Gr A)	
PZB	
Hauptbahn	
80	
4413	
Nebenbahn	
80	
4413	
1.9	
2.6	
3.1	
0.8	
2.6	
0.4	
2.2	
0.9	

BAV 508 / 2

Basel Bad Rbf Weil (Rh) - Haltingen	
GWB	
LZB und PZB	
Hauptbahn	
130 <160 >	
4000	
160	
2.0	
2.8	
1.1	
2.7	
3.3	
2.0	
2.9	
2.0	2.9

BAV 521 / 1

Basel Bad Rbf Weil (Schlaufe)	
PZB	
Nebenbahn	
60	
4411	
2.7	
3.5	0.8

Basel Bad Rbf Weil (Sig N10)	
PZB	
Hauptbahn	
60	
4415	
1.3	
0.0	1.3

Basel Bad Bf  
BR Einf SBB Pb

Basel Bad Bf  
BR Einf Multienz

Basel Bad Bf  
BR Rbf -Gr-L-  
Basel Rbf LGr  
BR Rbf -Gr-C-  
BR Rbf -Gr-A-

Basel Bad Bf  
Weil (Rhein) LGr  
Weil am Rhein  
Haltingen

BR Rbf -Gr-A-  
Weil am Rhein

BR Rbf -Gr-A-  
Weil am Rhein

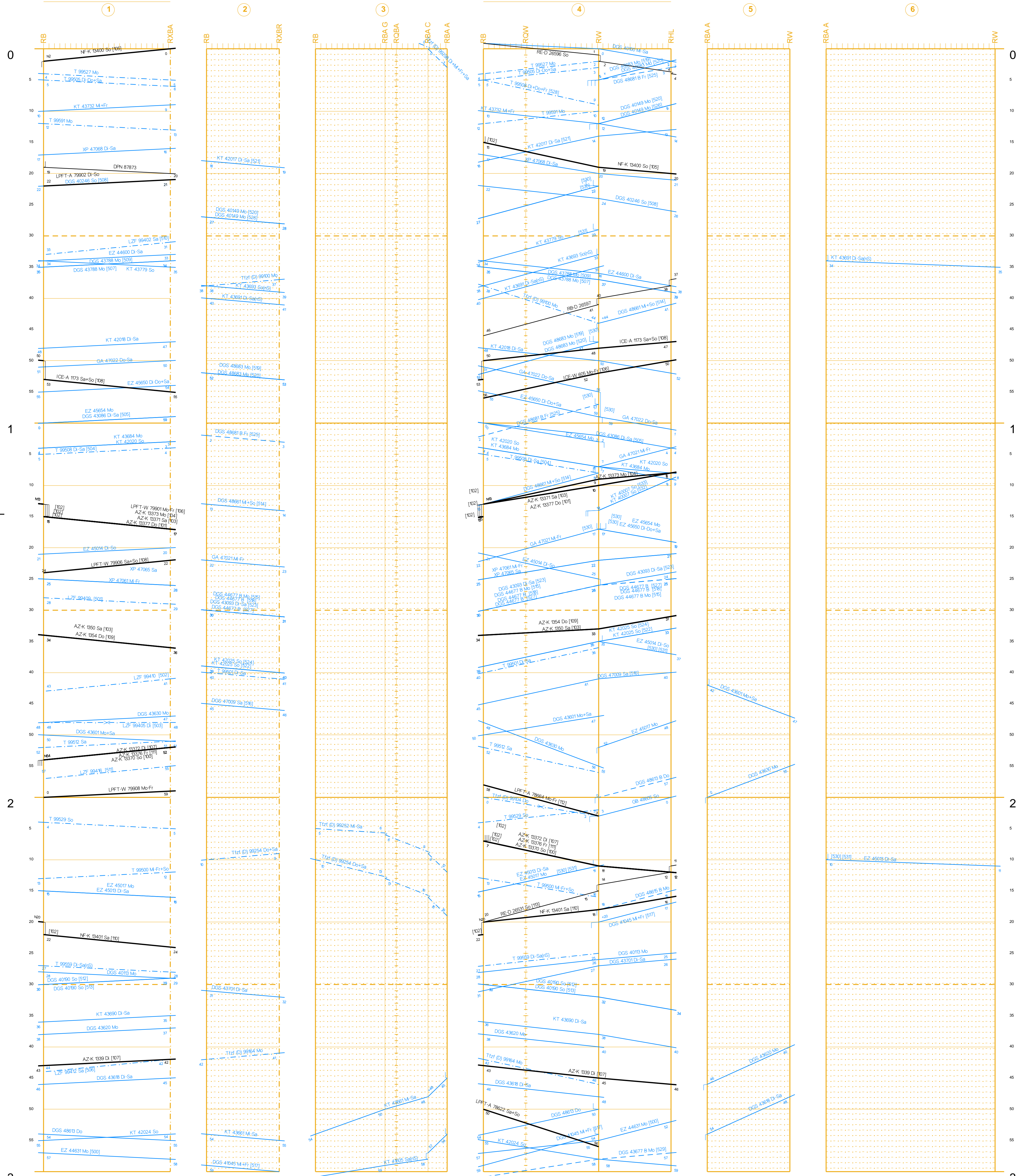

[100] 14.13 - 8.6.13 So	[108] auch: 29.13, 1.4.13, 9.5.13, 20.5.13	[133] auch: 29.13, 1.4.13, 1.5.13, 9.5.13, 20.5.13, 30.5.13	[500] nicht: 1.4.13, 20.5.13	[502] nicht: 1.4.13 - 1.4.13 Mo	[508] nicht: 31.3.13	[515] nicht: 18.3.13, 25.3.13, 1.4.13, 8.4.13	[523] nicht: 30.3.13, 2.4.13, 21.5.13, 18.3.13 - 21.5.13 So	[532] nicht: 18.3.13 - 2.4.13 So
[101] 9.5.13 - 8.6.13 Do	[109] 9.5.13 - 8.6.13 Do		[501] 18.3.13 - 2.4.13 Di	[503] 13.4.13 - 4.5.13 Sa	[509] 27.4.13 - 8.6.13 Sa	[516] nicht: 30.3.13	[524] 18.3.13 - 21.5.13 So	[533] 3.4.13 - 8.6.13 So
[102] Zugspitzenwechsel			[504] 14.4.13 - 5.5.13 So	[504] 11.5.13 - 1.6.13 Sa	[510] 19.4.13 - 4.5.13 Sa	[517] 8.4.13 - 8.6.13 Mi+Fr	[525] 18.3.13 - 21.5.13 Mo	
[103] 13.4.13 - 8.6.13 Sa	[110] 1.6.13 - 8.6.13 Sa		[505] 10.5.13	[505] 6.6.13 - 8.4.13 Do+Sa	[511] 9.5.13	[518] 18.3.13 - 21.5.13 Mo	[526] 18.3.13	
[104] 18.3.13 - 1.4.13 Mo	[111] 10.5.13 - 8.6.13 Fr		[506] 12.5.13 - 2.6.13 So	[506] 18.3.13 - 2.4.13 Di	[512] 18.3.13 - 20.5.13 So	[519] nicht: 20.5.13	[527] 25.3.13	
[105] 1.6.13 - 8.6.13 So	[112] nicht: 17.5.13, 24.5.13, 31.5.13, 10.5.13, 20.5.13		[507] 7.6.13 - 8.6.13 Fr+So	[507] 18.3.13 - 20.5.13 Di+Sa	[513] 21.5.13 - 8.6.13 So	[520] 22.5.13 - 8.6.13 Mo	[528] 22.5.13 - 8.6.13 Di+Do+Fr	
[106] nicht: 29.3.13, 1.4.13, 9.5.13, 10.5.13, 20.5.13			[508] 18.3.13 - 8.6.13 So	[508] 18.3.13 - 8.6.13 So	[514] nicht: 21.5.13, 30.3.13, 18.3.13 - 8.6.13 So	[521] 18.3.13 - 21.5.13 Di+Sa	[529] nicht: 1.4.13, 20.5.13	
[107] 18.3.13 - 2.4.13 Di			[509] 21.5.13 - 8.6.13 Mo	[509] nicht: 31.3.13, 3.4.13, 22.5.13		[530] Zugspitzenwechsel	[530] Zugspitzenwechsel	
						[522] 22.5.13 - 8.6.13 So	[531] Systemwechsel	







Fahrpläne Basel Nord Sued ab 18.03.2013

Stunden: 6 - 9

Basel Bad Bf Basel SBB Pb	
GWB	
PZB	
Hauptbahn	
70 <100 >	
4404	
1.8	
5.1	3.5

BAV 520

Basel Bad Bf

Basel Bad Bf Basel SBB Rb	
PZB	
Hauptbahn	
80	
4405	
0.9	
0.9	0.0

BAV 508 / 1

Basel Bad Bf

Basel Bad Bf Basel Rbf (GR A)	
PZB	
Hauptbahn	Nebenbahn
80	80
4405	4415
1.9	0.8
2.6	0.8
3.1	0.8
2.6	0.4
0.9	2.2

BAV 508 / 2

Basel Bad Bf

DB Netz

Niederlassung Südwest

Jahresfahrplan 2013 vom: 09. Dezember 2012 bis: 14. Dezember 2013  
Gültig vom: 18. März 2013 bis: 08. Juni 2013 / täglich

Basel Bad Rbf Weil (Rh) - Haltingen	
GWB	
LZB und PZB	
Hauptbahn	
130 <160 >	160
4000	
2.0	3.3
2.6	
2.0	
2.6	
2.0	2.3

BAV 521 / 1

Basel Bad Bf

Basel Bad Rbf Weil (Schlaufe)	
PZB	
Nebenbahn	
80	
4415	
2.7	
3.5	
0.8	

Basel Rbf -GR-A

Basel Bad Rbf Weil (Sig N10)	
PZB	
Hauptbahn	
80	
4415	
1.3	
0.0	
1.3	

Basel Rbf -GR-A

Stunden: 6 - 9

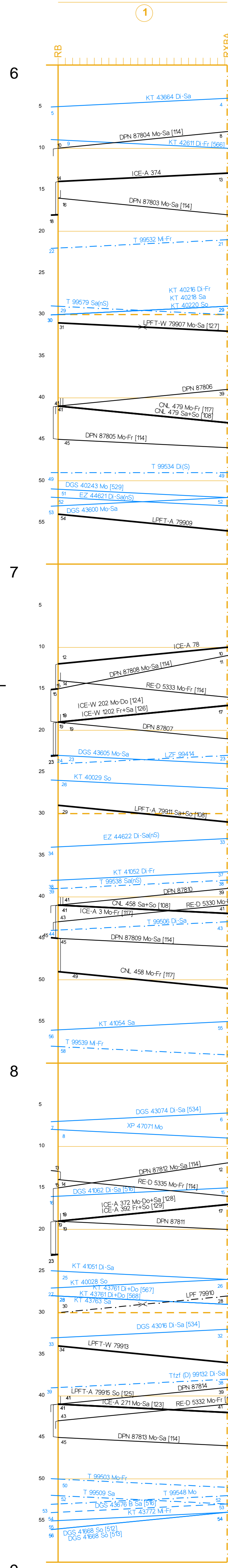

[108] auch: 29.3.13, 1.4.13, 8.5.13, [123] nicht: 28.3.13, 1.4.13, 20.5.13, [126] nicht: 28.3.13, 1.4.13, 8.5.13, 20.5.13  
 [114] auch: 29.3.13, 1.4.13, 1.5.13, 9.5.13, 20.5.13, [125] auch: 28.3.13, 31.3.13, 10.5.13, 19.5.13, [129] nicht: 29.3.13, 31.3.13, 10.5.13, 19.5.13  
 [116] nicht: 29.3.13, 1.4.13, 1.5.13, 9.5.13, 20.5.13, [127] nicht: 1.4.13, 20.5.13, auch: 31.3.13, 19.5.13, 20.5.13  
 [117] nicht: 29.3.13, 1.4.13, 8.5.13, 20.5.13

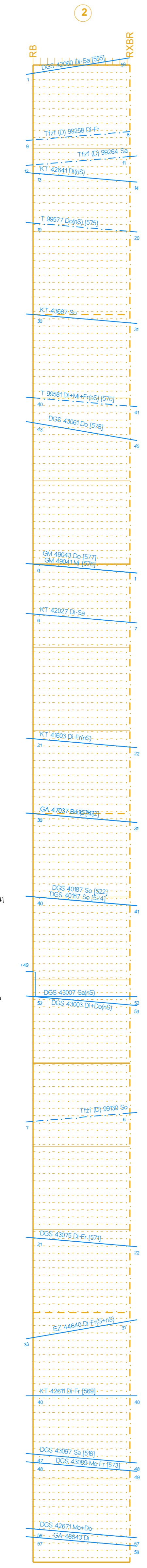

[108] auch: 29.3.13, 1.4.13, 8.5.13, [123] nicht: 28.3.13, 1.4.13, 20.5.13, [126] nicht: 28.3.13, 1.4.13, 8.5.13, 20.5.13  
 [114] auch: 29.3.13, 1.4.13, 1.5.13, 9.5.13, 20.5.13, [125] auch: 28.3.13, 31.3.13, 10.5.13, 19.5.13, [129] nicht: 29.3.13, 31.3.13, 10.5.13, 19.5.13  
 [116] nicht: 29.3.13, 1.4.13, 1.5.13, 9.5.13, 20.5.13, [127] nicht: 1.4.13, 20.5.13, auch: 31.3.13, 19.5.13, 20.5.13  
 [117] nicht: 29.3.13, 1.4.13, 8.5.13, 20.5.13

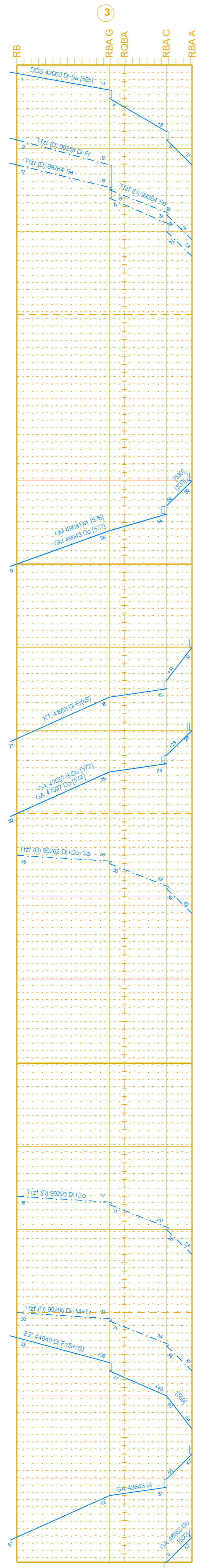

[108] auch: 29.3.13, 1.4.13, 8.5.13, [123] nicht: 28.3.13, 1.4.13, 20.5.13, [126] nicht: 28.3.13, 1.4.13, 8.5.13, 20.5.13  
 [114] auch: 29.3.13, 1.4.13, 1.5.13, 9.5.13, 20.5.13, [125] auch: 28.3.13, 31.3.13, 10.5.13, 19.5.13, [129] nicht: 29.3.13, 31.3.13, 10.5.13, 19.5.13  
 [116] nicht: 29.3.13, 1.4.13, 1.5.13, 9.5.13, 20.5.13, [127] nicht: 1.4.13, 20.5.13, auch: 31.3.13, 19.5.13, 20.5.13  
 [117] nicht: 29.3.13, 1.4.13, 8.5.13, 20.5.13

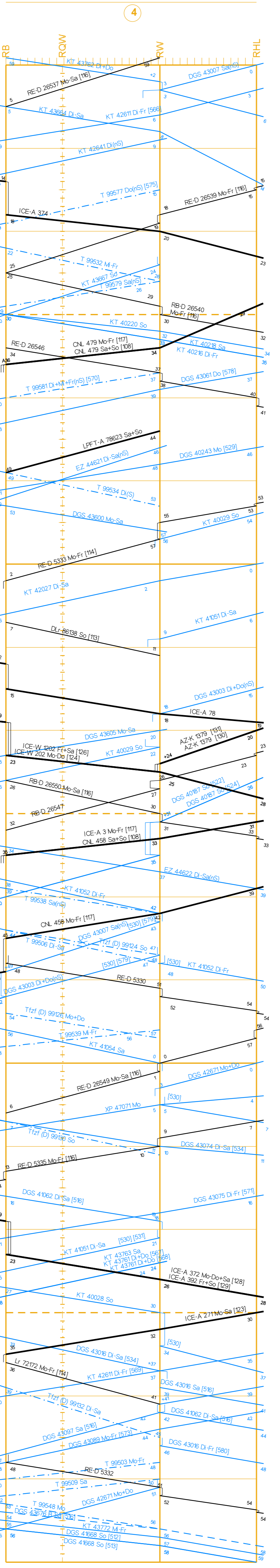

[108] auch: 29.3.13, 1.4.13, 8.5.13, [123] nicht: 28.3.13, 1.4.13, 20.5.13, [126] nicht: 28.3.13, 1.4.13, 8.5.13, 20.5.13  
 [114] auch: 29.3.13, 1.4.13, 1.5.13, 9.5.13, 20.5.13, [125] auch: 28.3.13, 31.3.13, 10.5.13, 19.5.13, [129] nicht: 29.3.13, 31.3.13, 10.5.13, 19.5.13  
 [116] nicht: 29.3.13, 1.4.13, 1.5.13, 9.5.13, 20.5.13, [127] nicht: 1.4.13, 20.5.13, auch: 31.3.13, 19.5.13, 20.5.13  
 [117] nicht: 29.3.13, 1.4.13, 8.5.13, 20.5.13

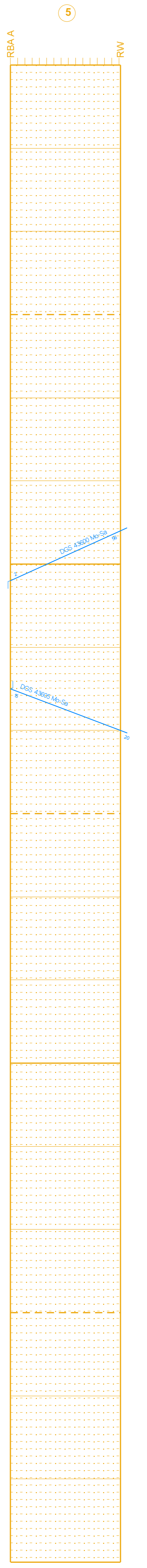

[108] auch: 29.3.13, 1.4.13, 8.5.13, [123] nicht: 28.3.13, 1.4.13, 20.5.13, [126] nicht: 28.3.13, 1.4.13, 8.5.13, 20.5.13  
 [114] auch: 29.3.13, 1.4.13, 1.5.13, 9.5.13, 20.5.13, [125] auch: 28.3.13, 31.3.13, 10.5.13, 19.5.13, [129] nicht: 29.3.13, 31.3.13, 10.5.13, 19.5.13  
 [116] nicht: 29.3.13, 1.4.13, 1.5.13, 9.5.13, 20.5.13, [127] nicht: 1.4.13, 20.5.13, auch: 31.3.13, 19.5.13, 20.5.13  
 [117] nicht: 29.3.13, 1.4.13, 8.5.13, 20.5.13

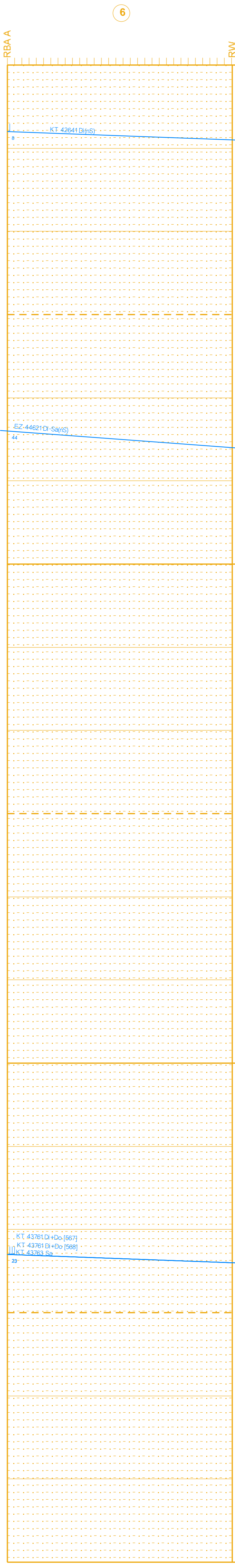

[108] auch: 29.3.13, 1.4.13, 8.5.13, [123] nicht: 28.3.13, 1.4.13, 20.5.13, [126] nicht: 28.3.13, 1.4.13, 8.5.13, 20.5.13  
 [114] auch: 29.3.13, 1.4.13, 1.5.13, 9.5.13, 20.5.13, [125] auch: 28.3.13, 31.3.13, 10.5.13, 19.5.13, [129] nicht: 29.3.13, 31.3.13, 10.5.13, 19.5.13  
 [116] nicht: 29.3.13, 1.4.13, 1.5.13, 9.5.13, 20.5.13, [127] nicht: 1.4.13, 20.5.13, auch: 31.3.13, 19.5.13, 20.5.13  
 [117] nicht: 29.3.13, 1.4.13, 8.5.13, 20.5.13



Station	09	10	11	12
Basel Bad Bf				
Basel SBB Pb				

BAV 520

Station	09	10	11	12
Basel Bad Bf				
Basel SBB Rb				

BAV 508 / 1

Station	09	10	11	12
Basel Bad Bf				
Basel Bad Rbf (GR A)				

BAV 508 / 2

Station	09	10	11	12
Basel Bad Bf				
Basel Bad Rbf				
Weil (Rh)- Haltungen				

BAV 521 / 1

Station	09	10	11	12
Basel Bad Rbf				
Weil (Schlaufe)				

Station	09	10	11	12
Basel Bad Rbf				
Weil (Sig N10)				

Basel Bad Bf

BR Einf SBB RB

Basel Bad Bf  
BR Einf (Mittelnz)

Basel Bad Bf  
BR Rbf -Gr-L-  
Basel Rbf LG-  
BR Rbf -Gr-C-  
BR Rbf -Gr-A-

Basel Bad Bf  
Weil (Rhein) LG

Basel Bad Bf  
Weil am Rhein

BR Rbf -Gr-A-

Weil am Rhein

BR Rbf -Gr-A-

Weil am Rhein

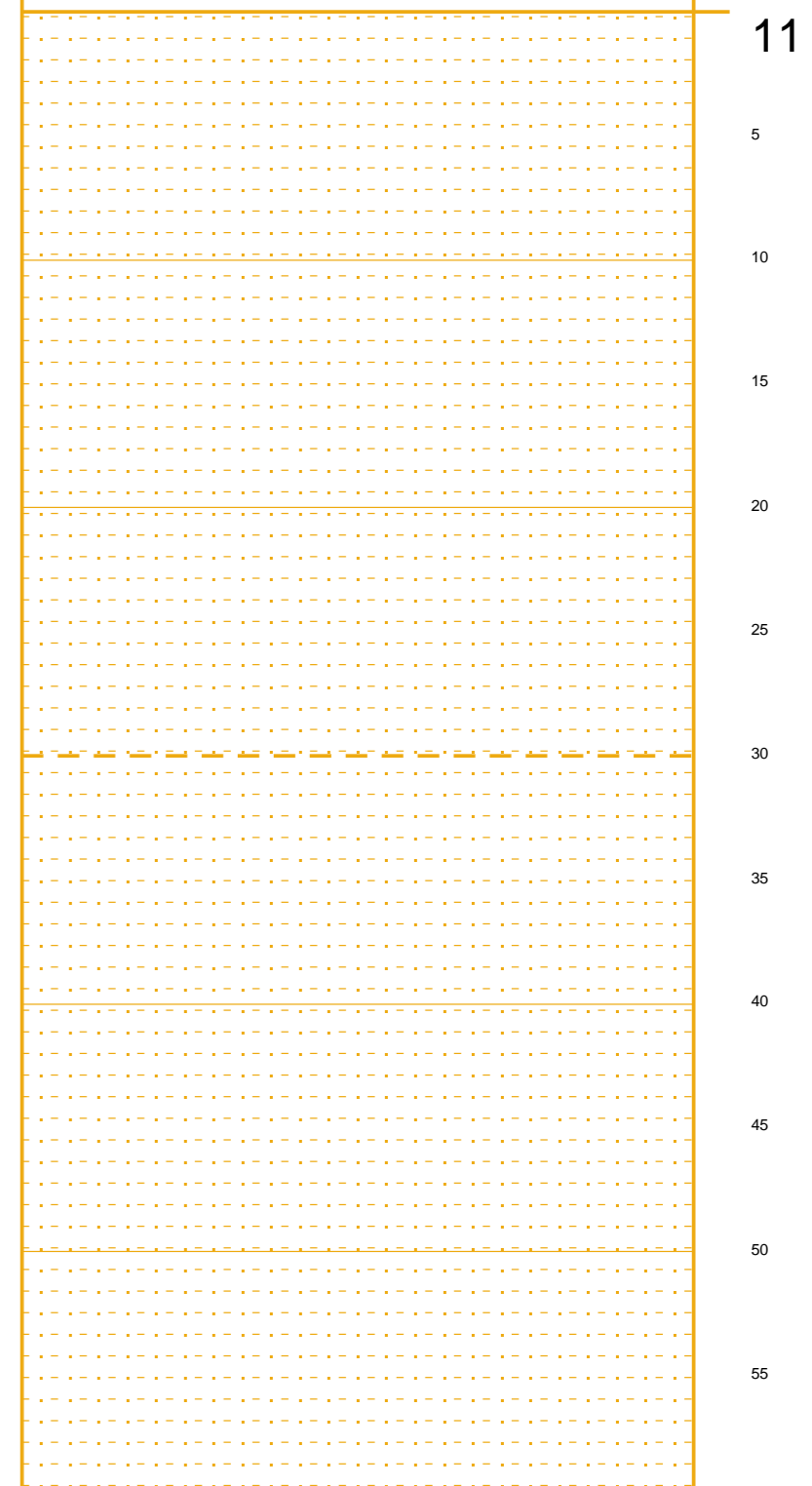
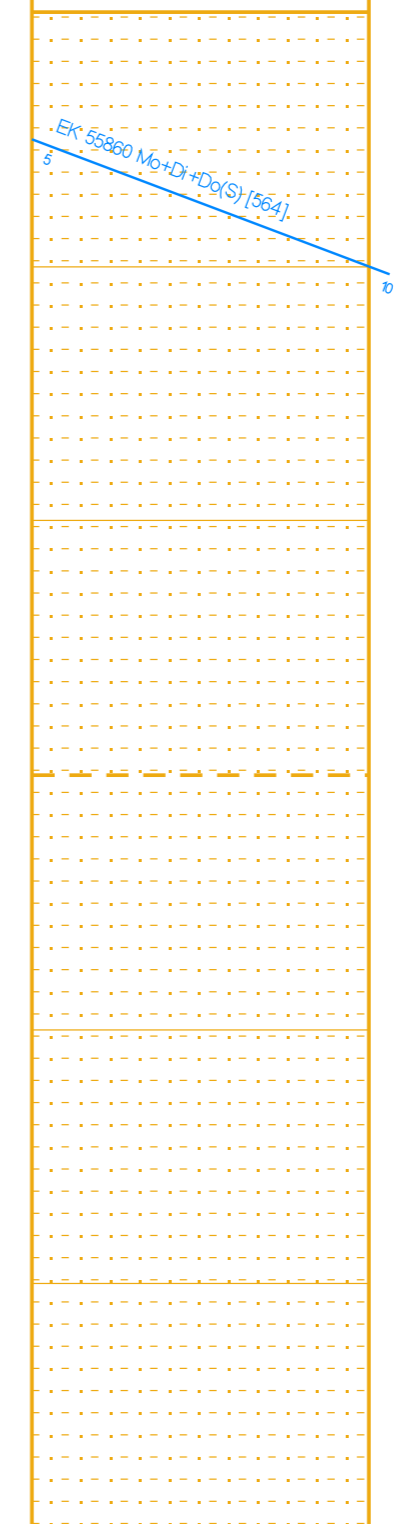
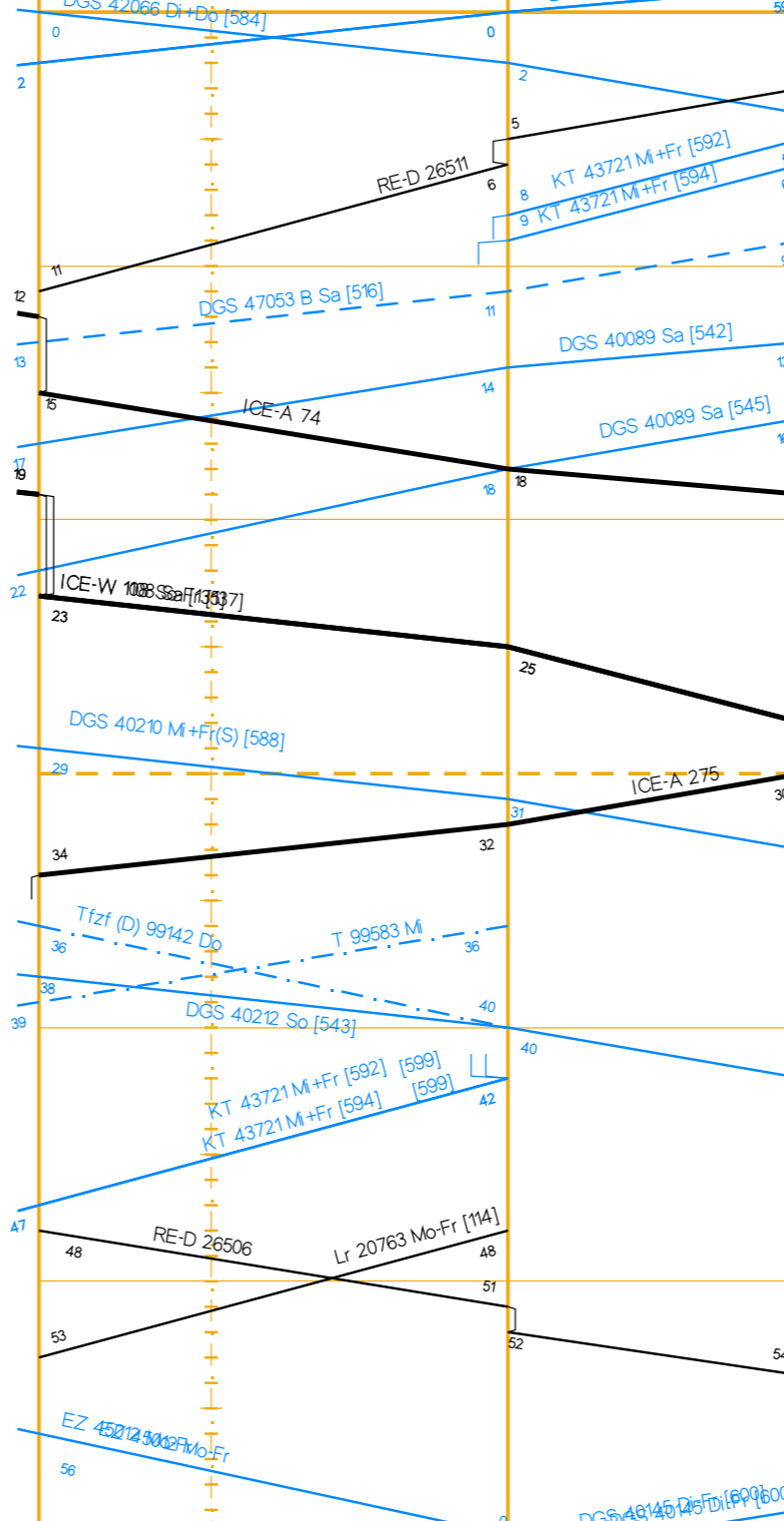
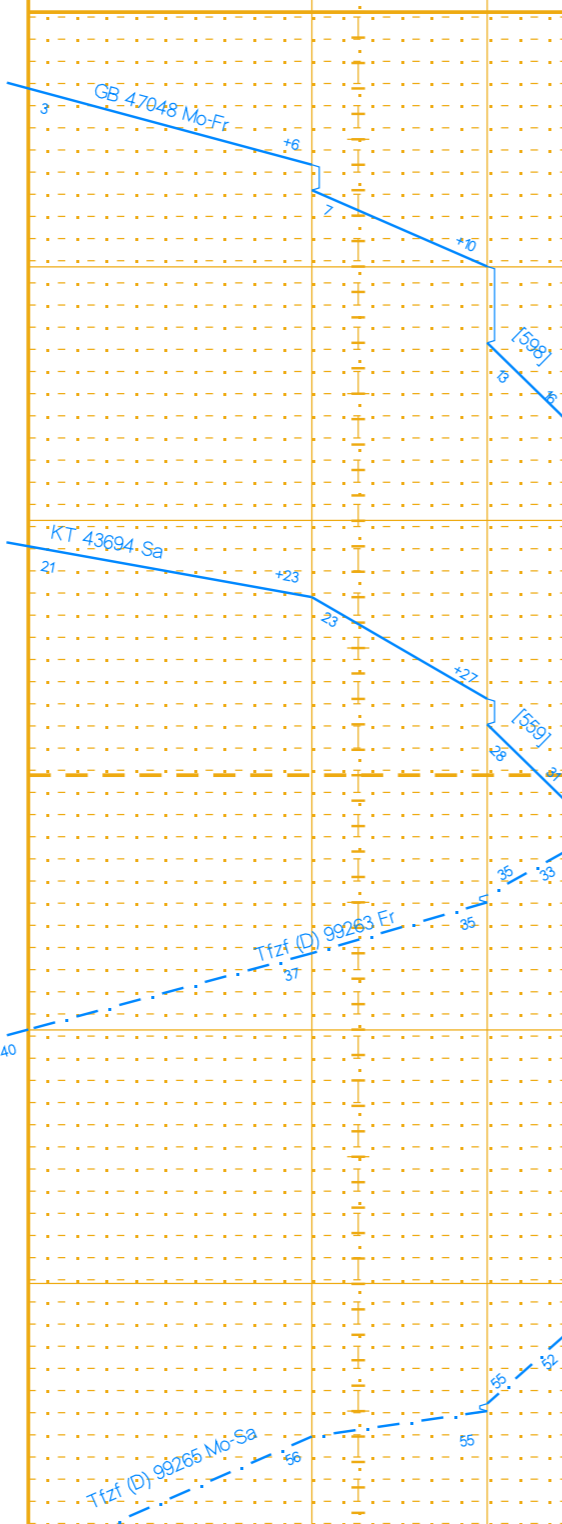
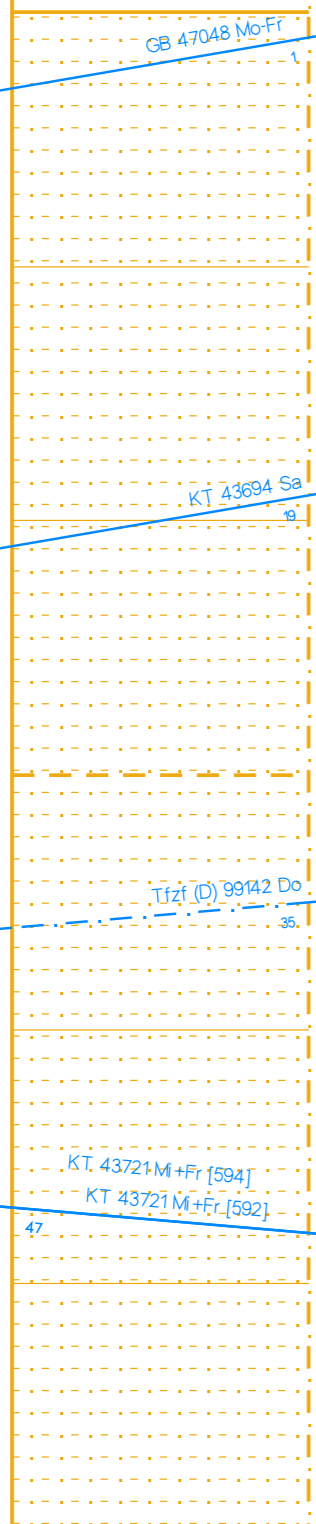
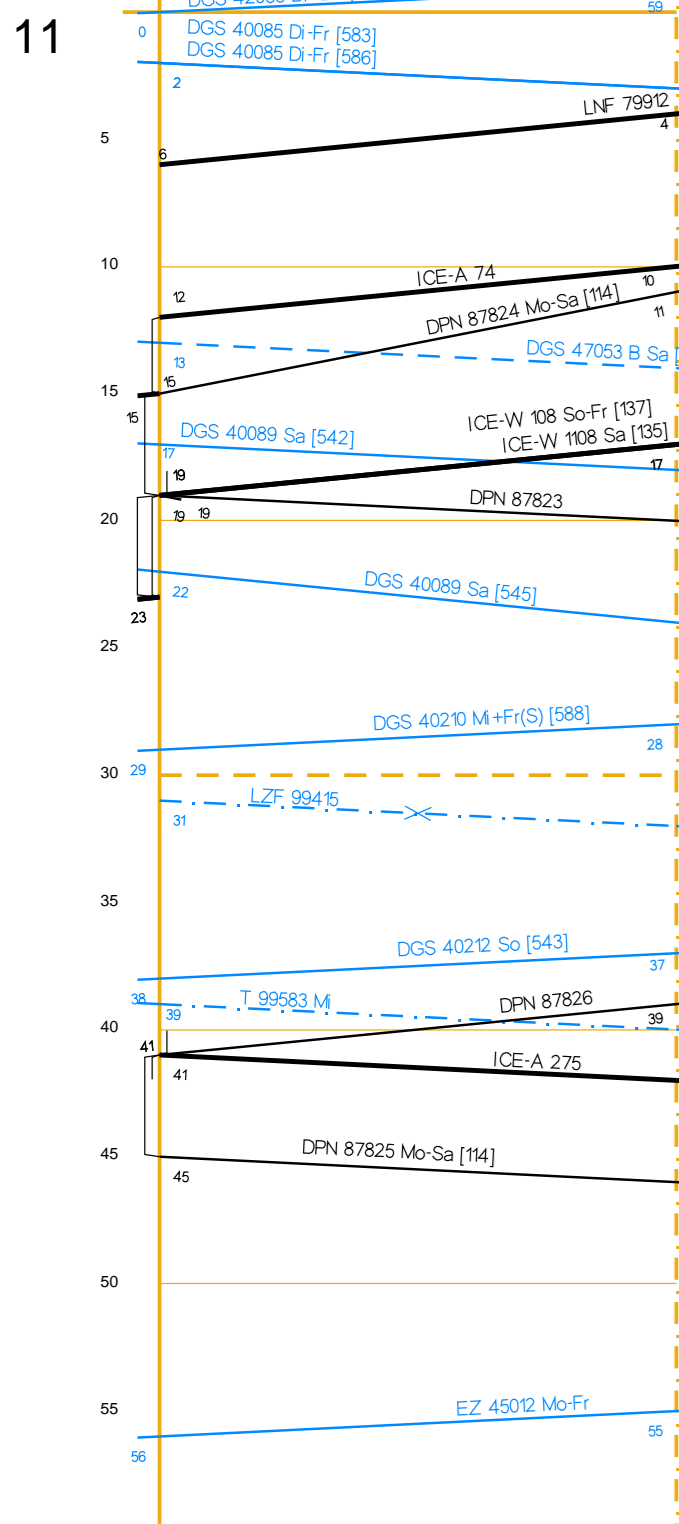
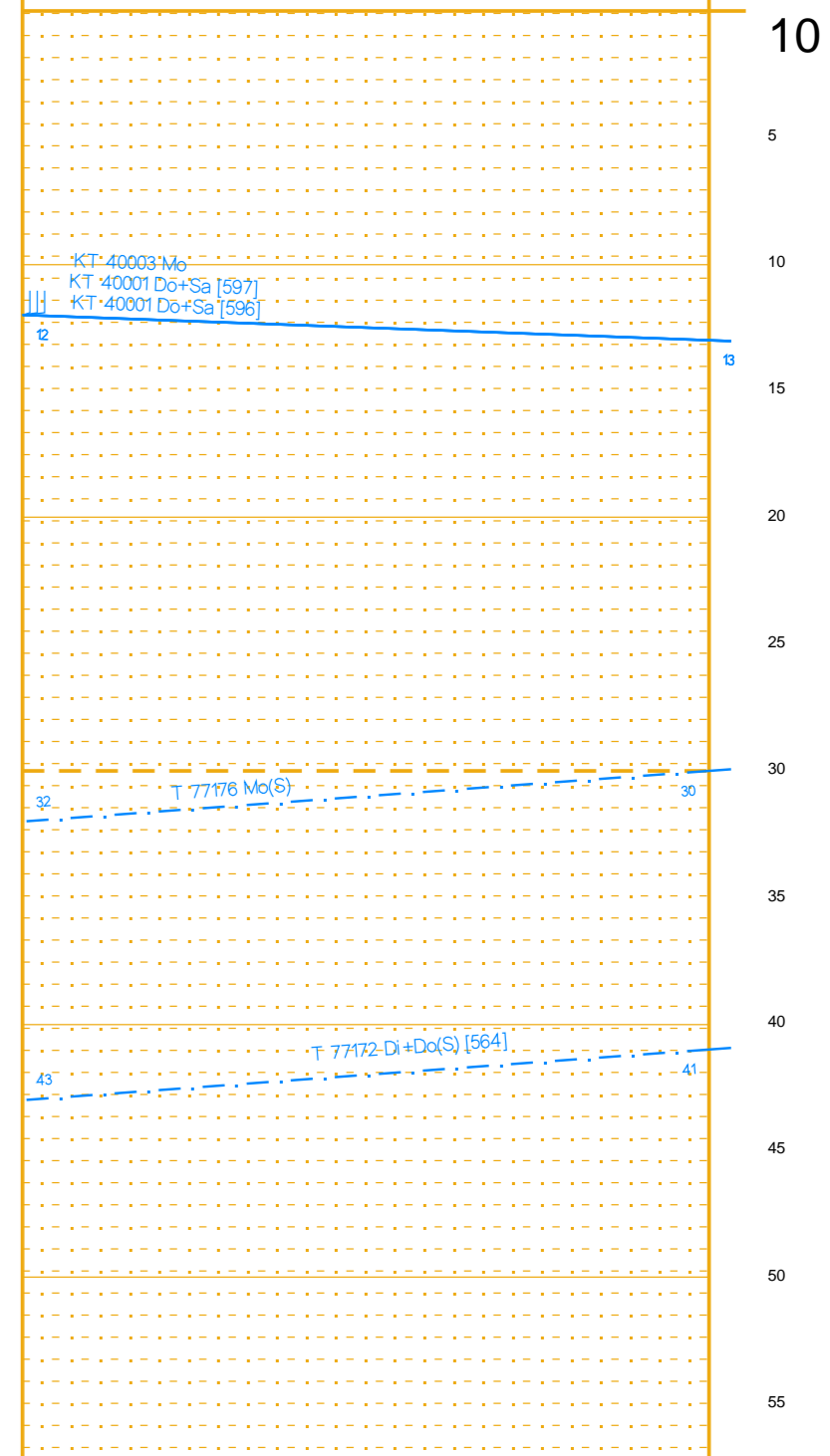
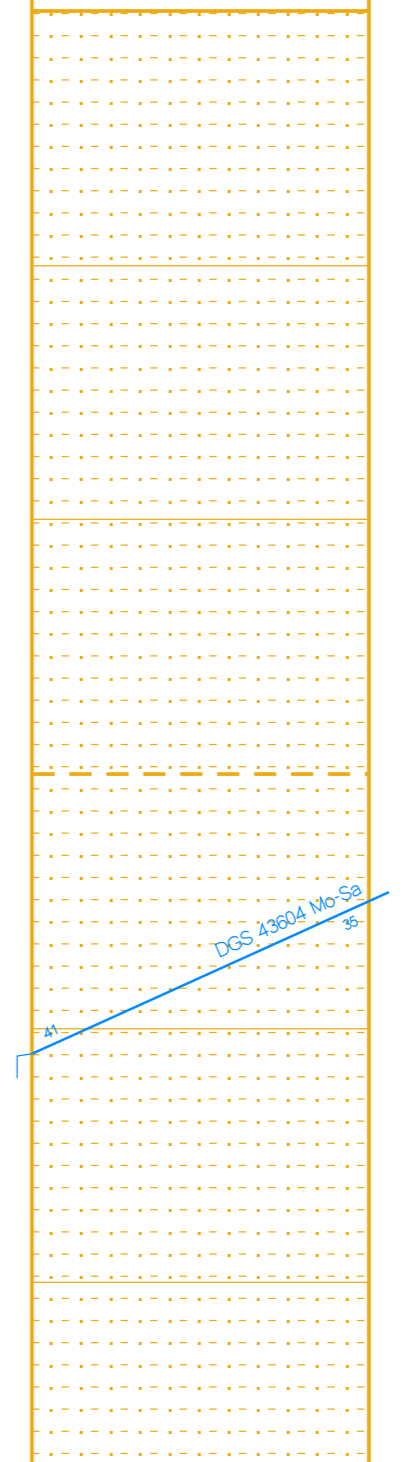
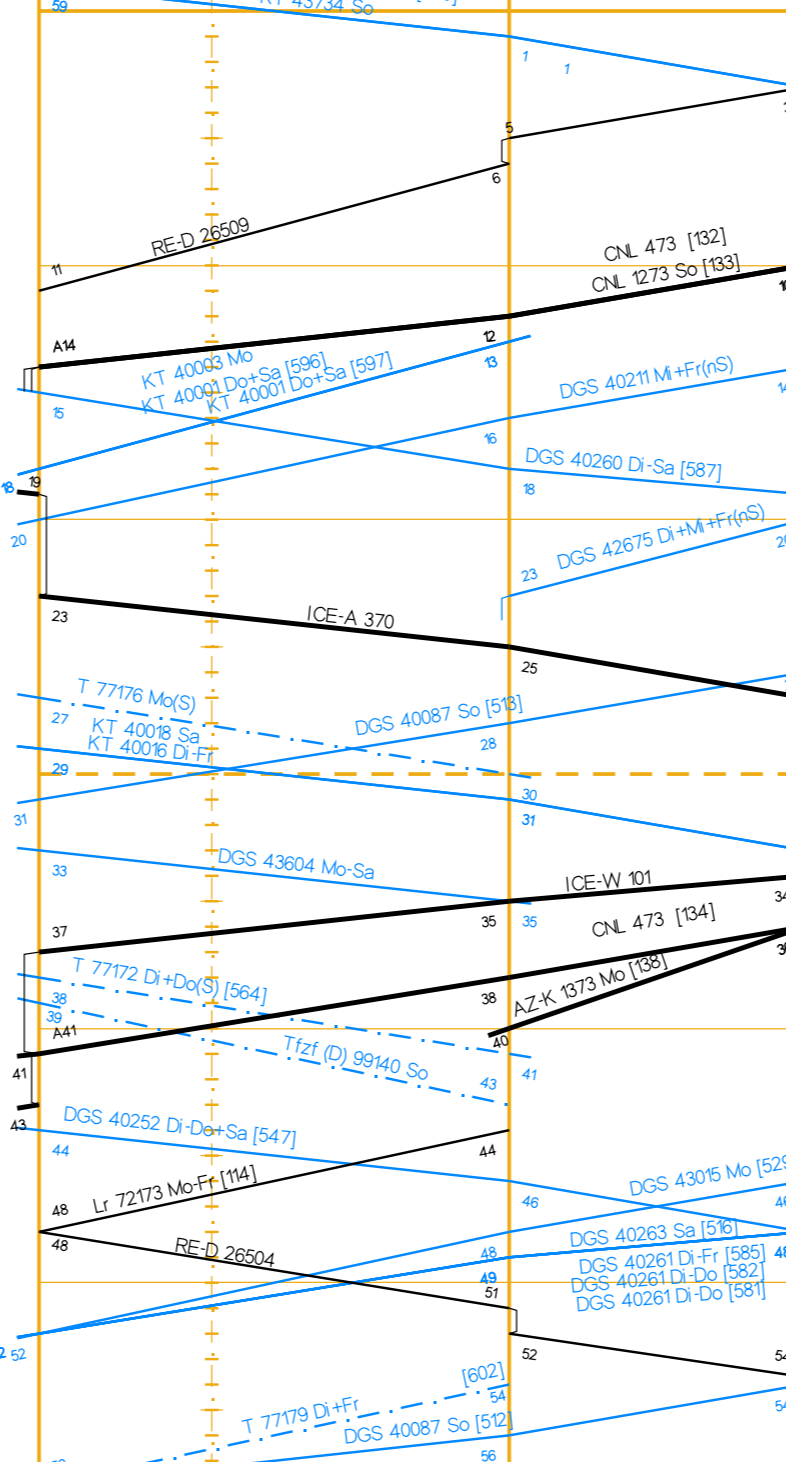
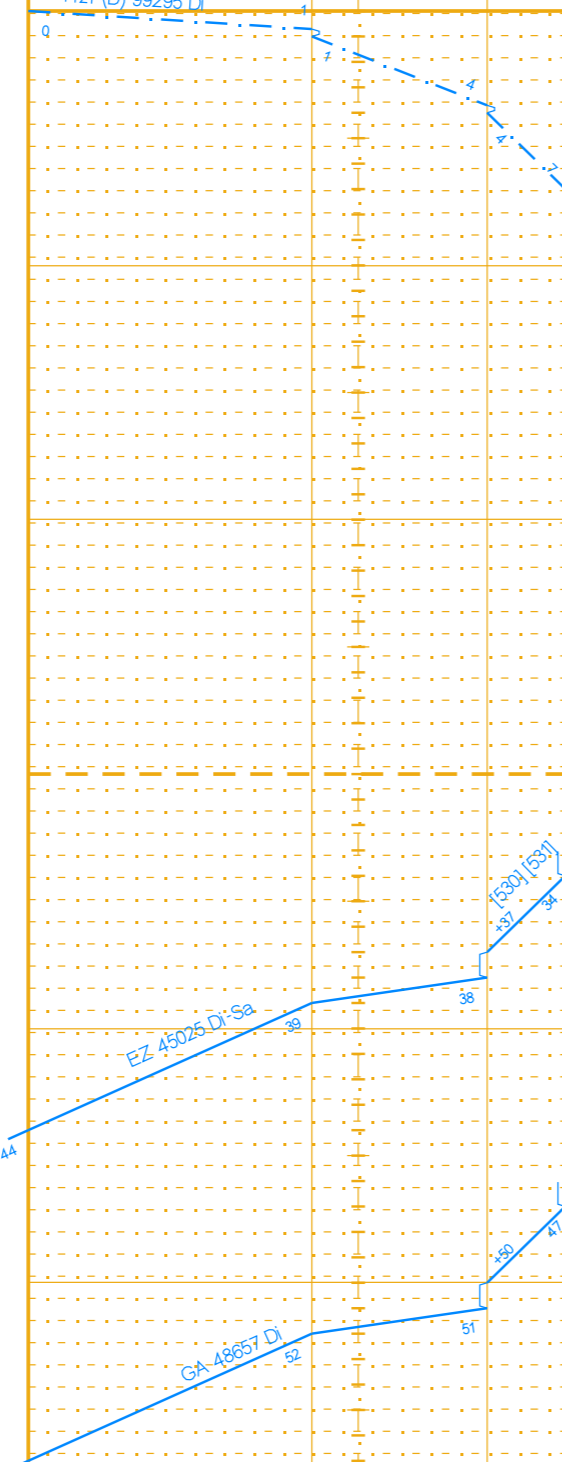
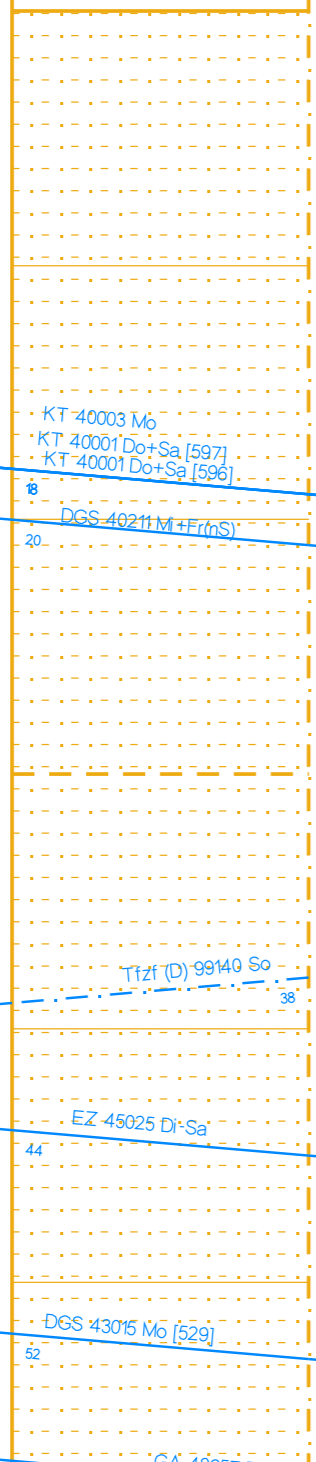
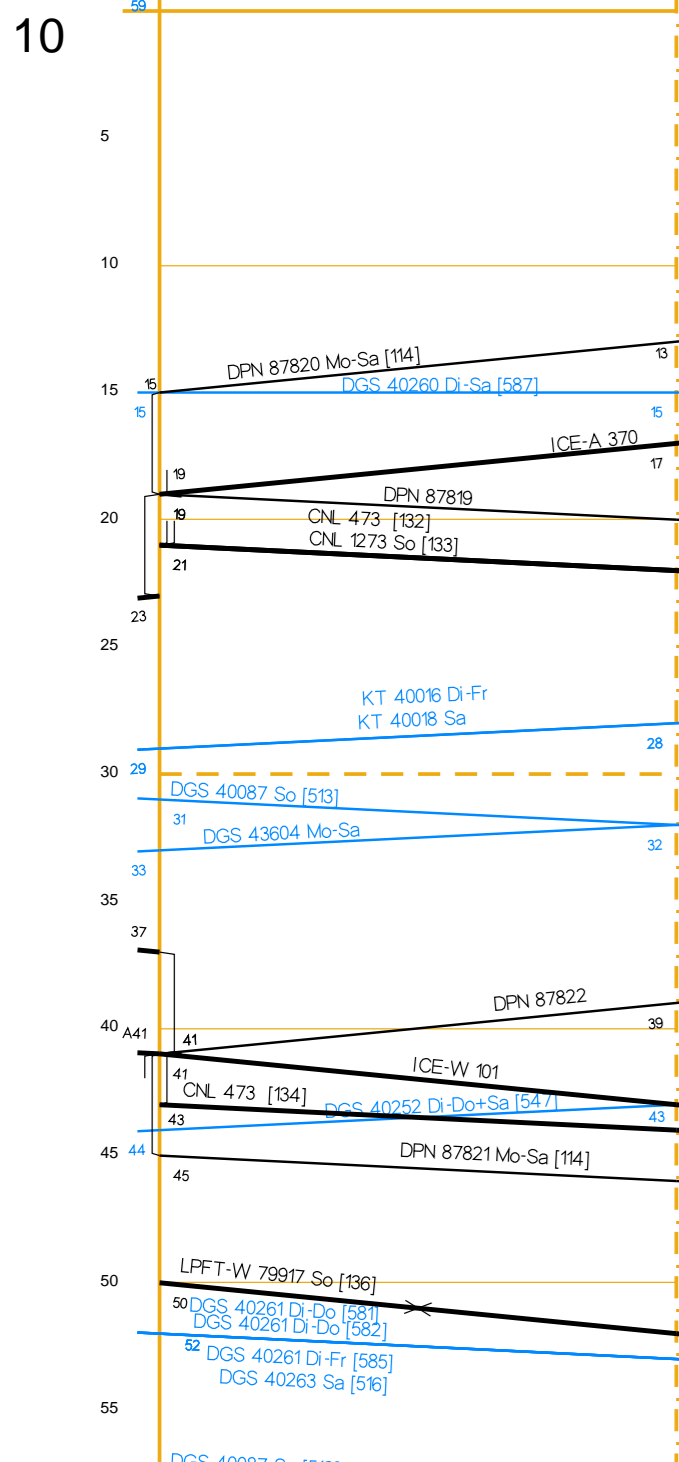
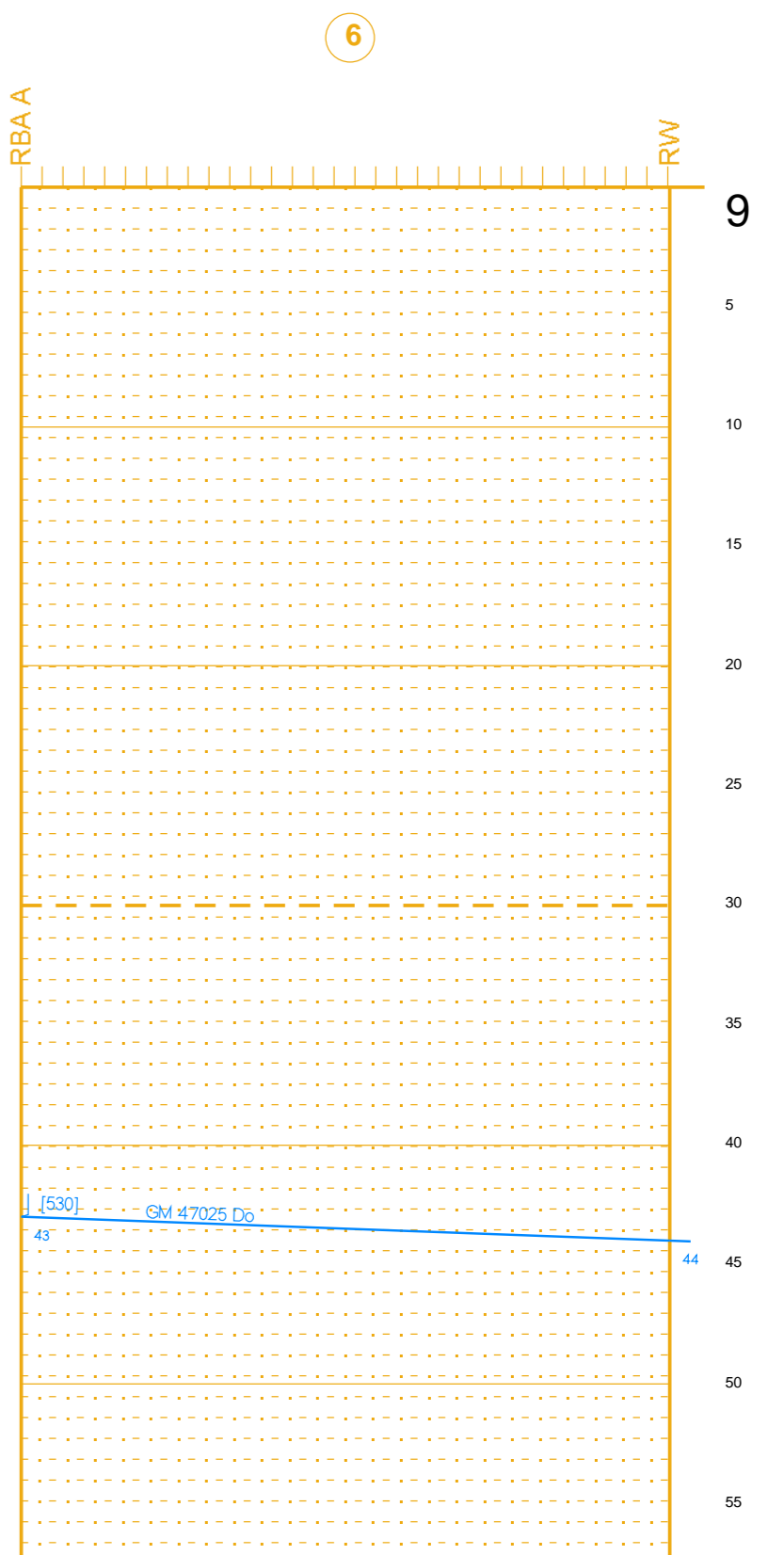
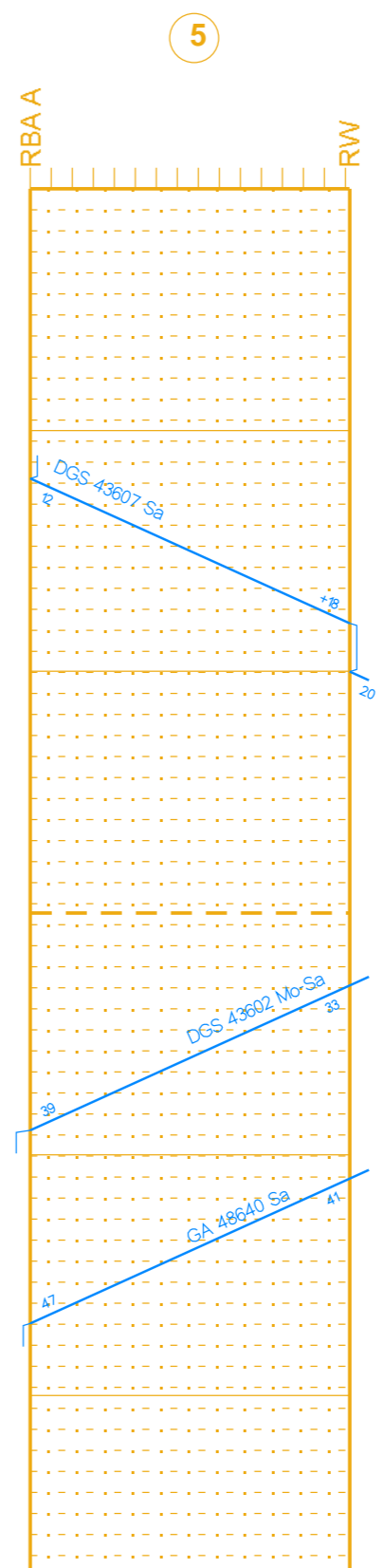
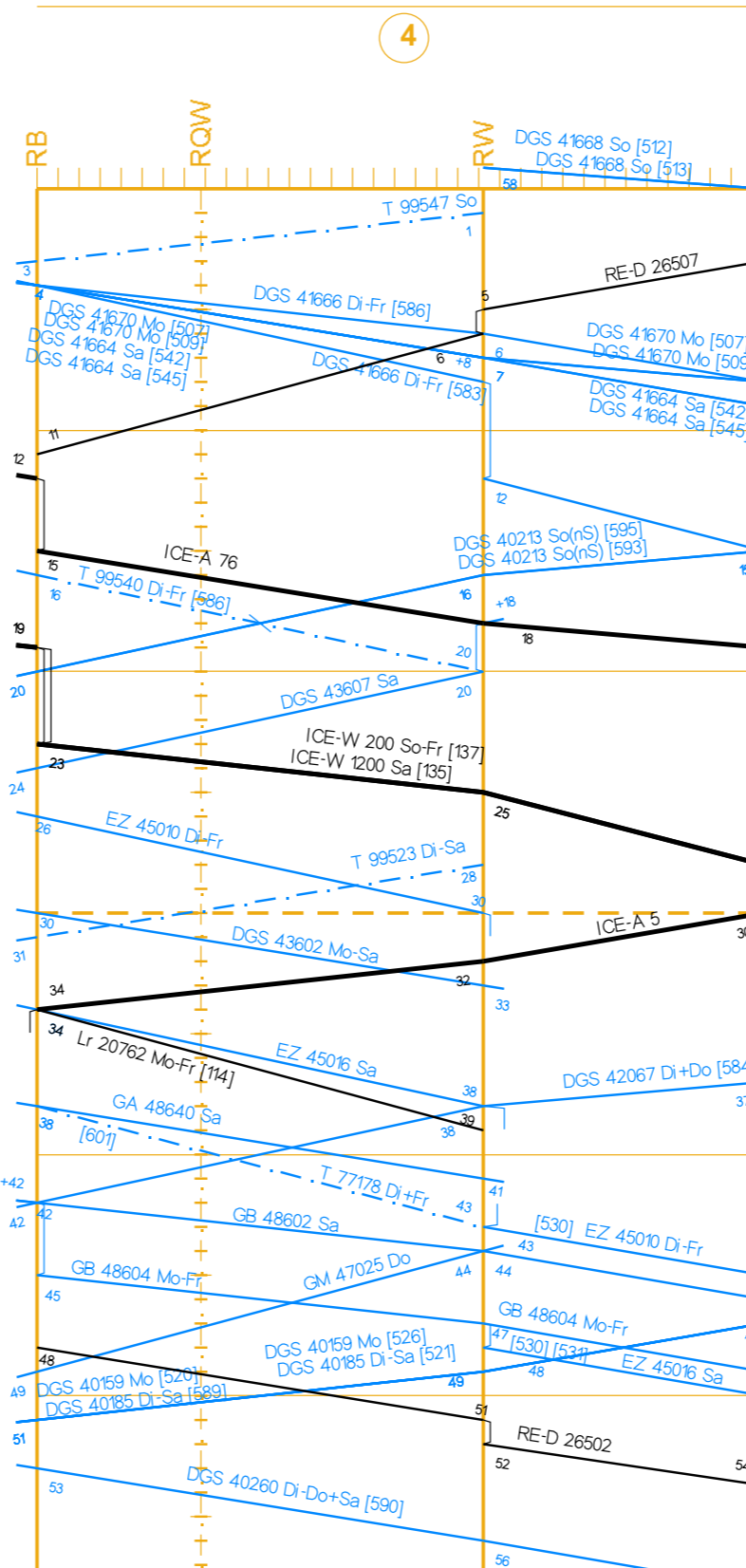
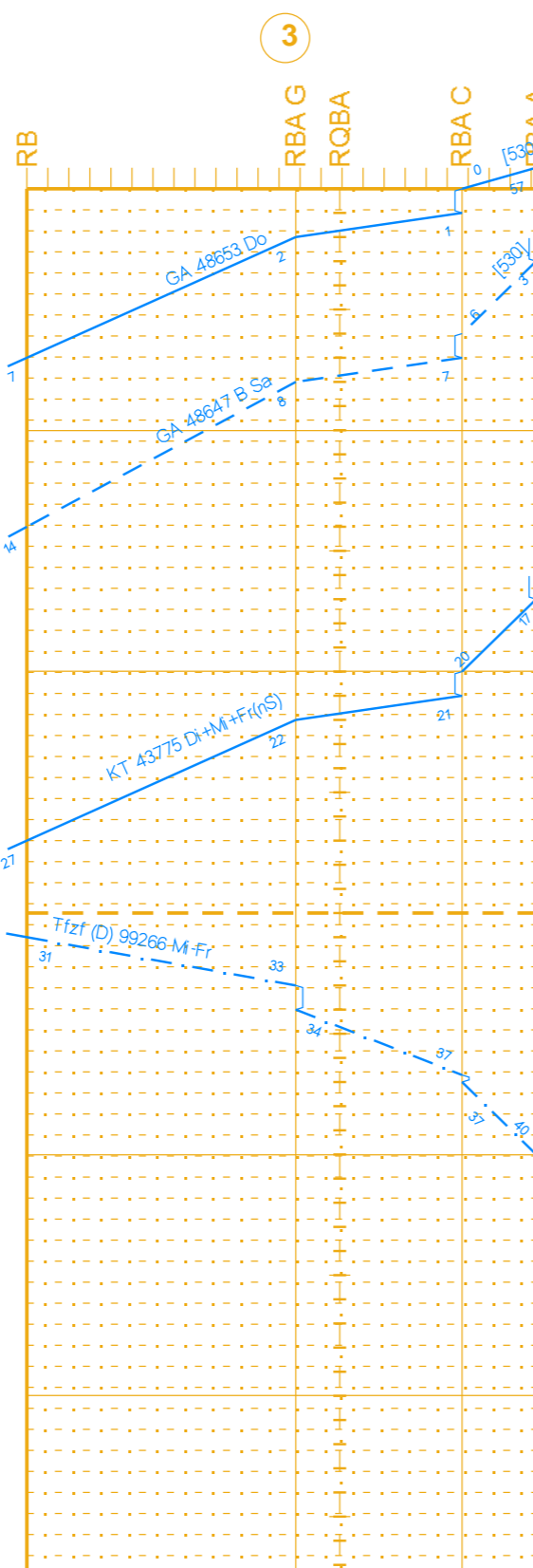
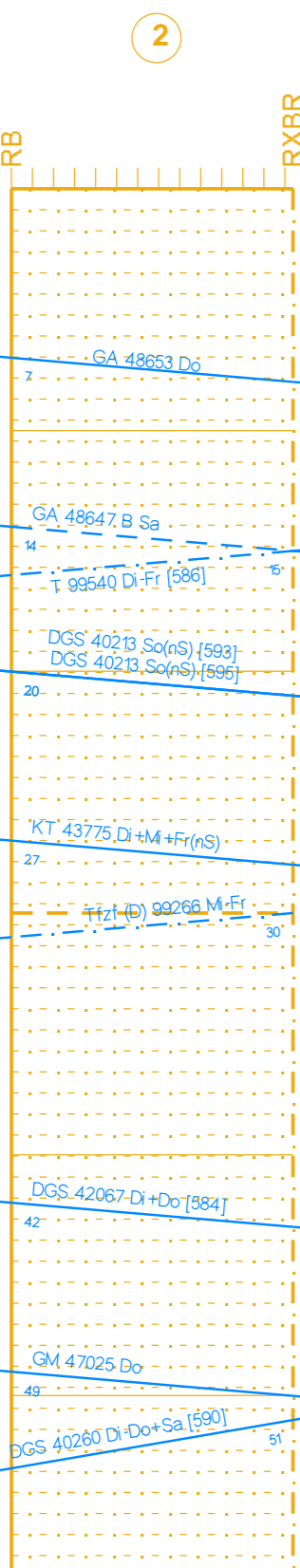
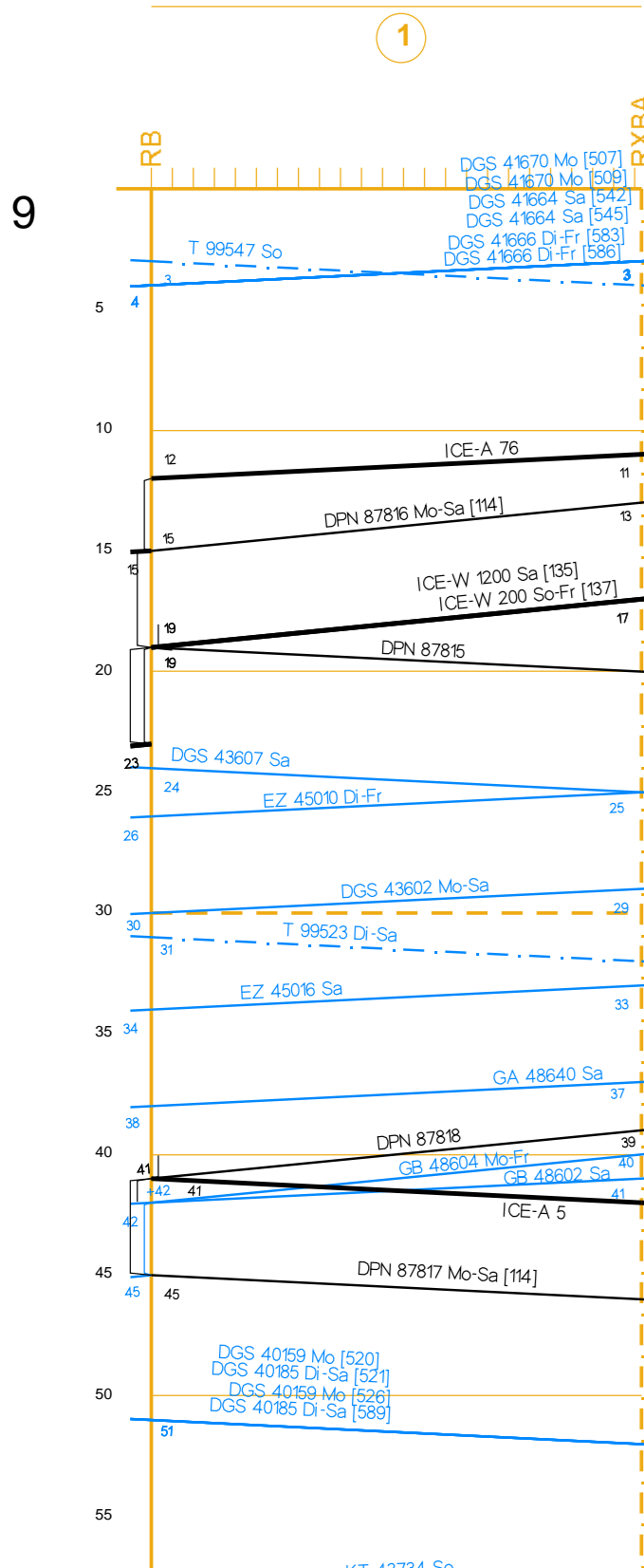

[114] nicht 29.3.13, 1.4.13, 1.5.13, 9.5.13, 20.5.13  
 [132] 18.3.13 - 11.5.13  
 nicht 30.3.13  
 13.5.13 - 8.6.13 Mo-Sa  
 13.5.13 - 8.6.13 So  
 verkehrt nur am 30.3.13  
 [136] auch 29.3.13, 31.3.13, 19.5.13  
 [138] nicht 1.4.13, 19.5.13  
 auch 1.4.13, 20.5.13, 31.5.13

[507] 21.5.13 - 8.6.13 Mo  
 [508] 18.3.13 - 20.5.13 Mo  
 [512] 18.3.13 - 20.5.13 So  
 [513] 21.5.13 - 8.6.13 So  
 [516] nicht 30.3.13  
 [520] 22.5.13 - 8.6.13 Mo  
 [521] 18.3.13 - 21.5.13 Mo  
 [528] nicht 1.4.13, 20.5.13  
 [530] Zugsprelnwechsel  
 [531] Systemwechsel  
 [542] 21.5.13 - 8.6.13 Sa  
 [543] 18.3.13 - 8.6.13 So  
 [545] 18.3.13 - 20.5.13 Sa  
 [547] nicht 30.3.13, 2.4.13  
 [559] Gleisenübergangsbearbeitung  
 [564] nicht 30.3.13  
 [580] nicht 29.3.13, 2.4.13  
 [581] 8.4.13 - 20.5.13 Do  
 [582] 21.5.13 - 8.6.13 Di-Do

[583] 21.5.13 - 8.6.13 Di-Fr  
 [584] nicht 29.3.13, 2.4.13  
 [585] 18.3.13 - 7.4.13 Di-Fr  
 nicht 29.3.13, 2.4.13  
 [586] 18.3.13 - 20.5.13 Di-Fr  
 nicht 29.3.13, 2.4.13  
 [587] 18.3.13 - 20.5.13 Di-Sa  
 nicht 29.3.13, 30.3.13, 2.4.13  
 [588] 1.4.13 - 8.6.13 Di-Fr(S)  
 [589] nicht 21.5.13 - 8.6.13 Di-Sa  
 [590] 21.5.13 - 8.6.13 Di-Do-Sa

[592] 18.3.13 - 21.5.13 Mo+Fr  
 [593] 2.4.13 - 8.6.13 So(F)  
 [594] 22.5.13 - 8.6.13 Mo+Fr  
 [595] 18.3.13 - 1.4.13 So(F)  
 nicht 31.3.13  
 [596] 18.3.13 - 2.4.13 Do-Sa  
 [597] 3.4.13 - 8.6.13 Do-Sa  
 [598] Ubergang auf SBB von 52850 + 52858  
 [599] Nonstop zu  
 [600] 1.4.13 - 8.6.13 Di-Fr

[601] weiter als Rf nach RBA / RHL zu DK  
 [602] aus Rf / RBA / RHL von DK

[603] RB  
 [604] ROW  
 [605] RW  
 [606] RHL  
 [607] RBAA  
 [608] RW

[609] RBAA  
 [610] RW



Fahrpläne Basel Nord Sued ab 18.03.2013

Stunden: 12 - 15

DB Netz

Niederlassung Südwest

Jahresfahrplan 2013 vom: 09. Dezember 2012 bis: 14. Dezember 2013  
Gültig vom: 18. März 2013 bis: 08. Juni 2013 / täglich

Fahrpläne Basel Nord Sued ab 18.03.2013

Stunden: 12 - 15

Table with 2 columns: Station, Time. Includes Basel Bad Bf, Basel SBB Pb, GwB, PZB, Hauptbahn, Nebenbahn, 70 <100 >, 4404, 1.8, 3.5.

BAV 520

Table with 2 columns: Station, Time. Includes Basel Bad Bf, Basel SBB Rb, PZB, Hauptbahn, Nebenbahn, 60, 4405, 0.9, 0.9, 0.0.

BAV 508 / 1

Table with 2 columns: Station, Time. Includes Basel Bad Bf, Basel Bad Rbf(Gr A), PZB, Hauptbahn, Nebenbahn, 60, 4405, 0.9, 1.9, 2.6, 3.1, 0.8, 2.6, 0.4, 2.2.

BAV 508 / 2

Table with 2 columns: Station, Time. Includes Basel Bad Rbf, Weil (Rh) - Haltungen, GwB, LZB und PZB, Hauptbahn, Nebenbahn, 130 <160 >, 4000, 160, 270.7, 2.0, 288.7, 1.1, 207.6, 3.3, 294.3.

BAV 521 / 1

Table with 2 columns: Station, Time. Includes Basel Bad Rbf, Weil (Schlaufe), PZB, Nebenbahn, Hauptbahn, 60, 4411, 2.7, 0.8.

BAV 521 / 1

Table with 2 columns: Station, Time. Includes Basel Bad Rbf, Weil (Sig N10), PZB, Hauptbahn, Nebenbahn, 60, 4415, 1.3, 0.0, 1.3.

BAV 521 / 1

Basel Bad Bf  
BR Einf SBB Pb

Basel Bad Bf  
BR Einf Mültlenz

Basel Bad Bf  
BR Rbf -Gr-L-  
Basel Rbf LGr  
BR Rbf -Gr-C-  
BR Rbf -Gr-A-

Basel Bad Bf  
Weil (Rhein) LGr  
Weil am Rhein  
Haltungen

Basel Bad Rbf -Gr-A-  
Weil am Rhein

Basel Bad Rbf -Gr-A-  
Weil am Rhein

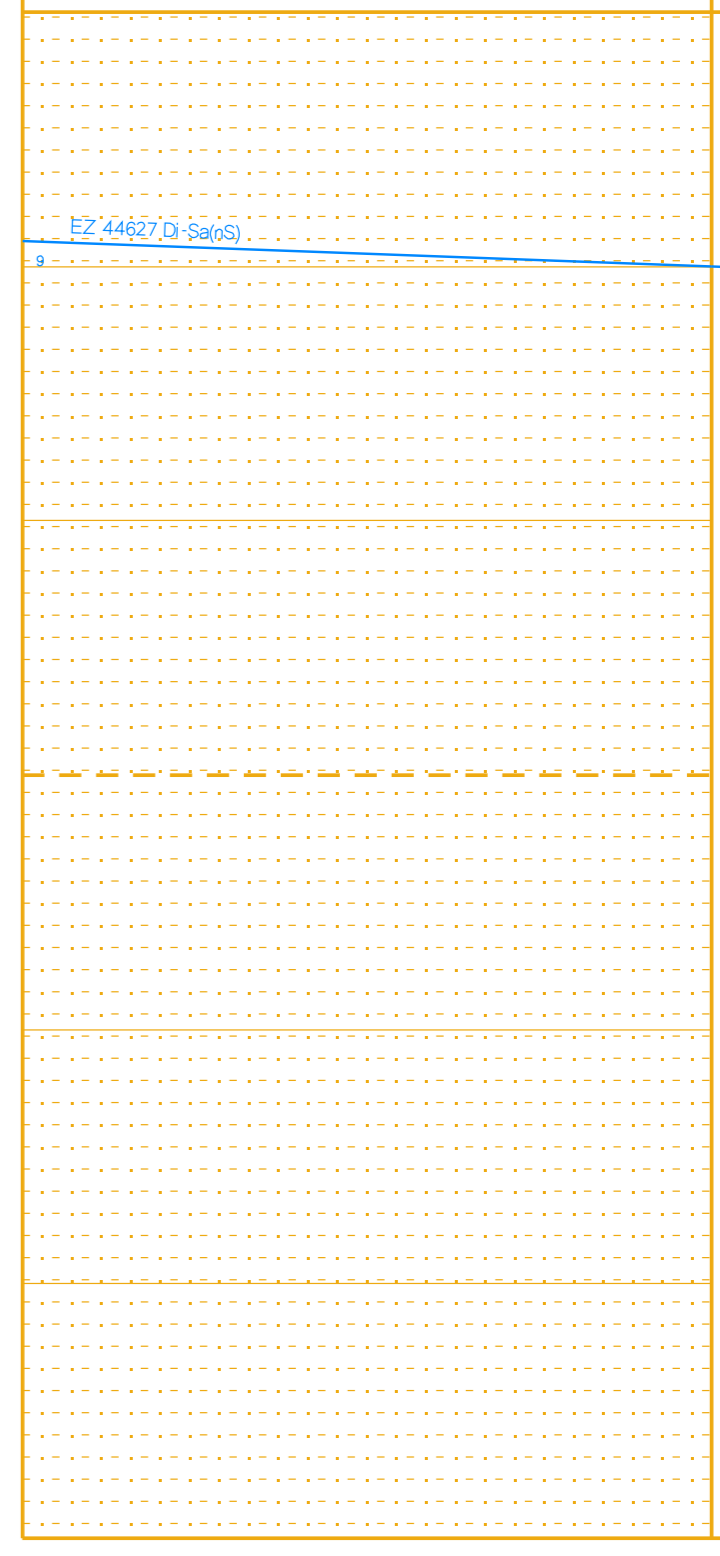
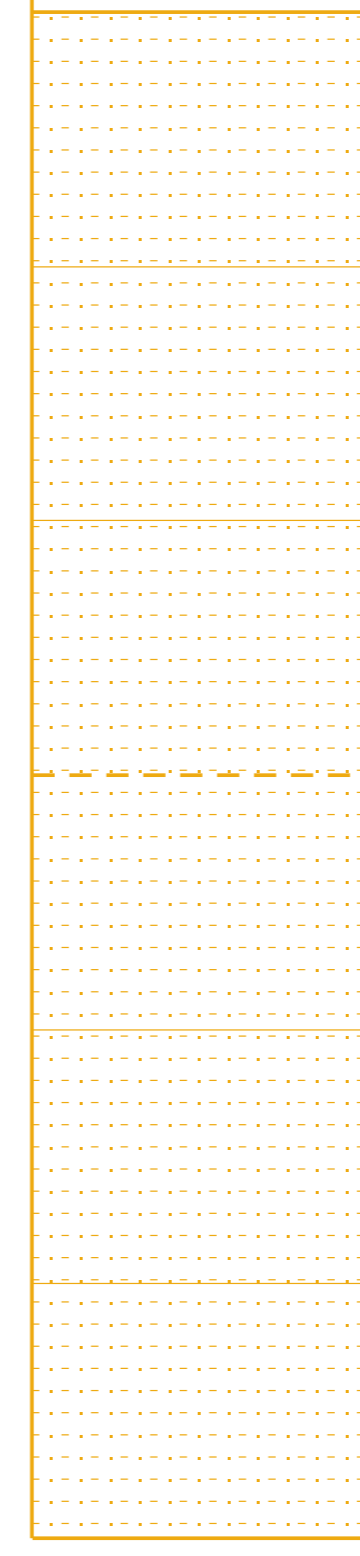
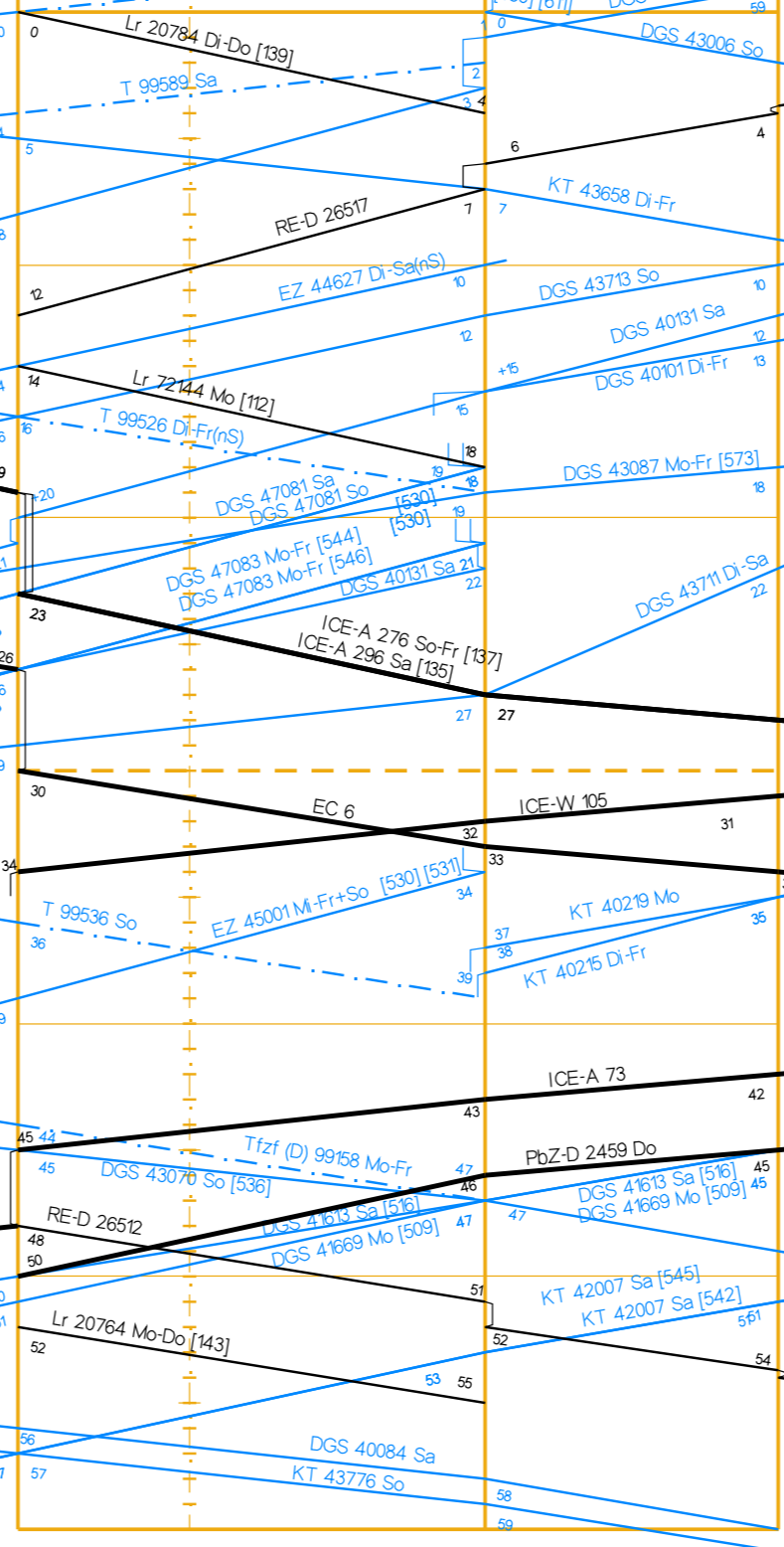
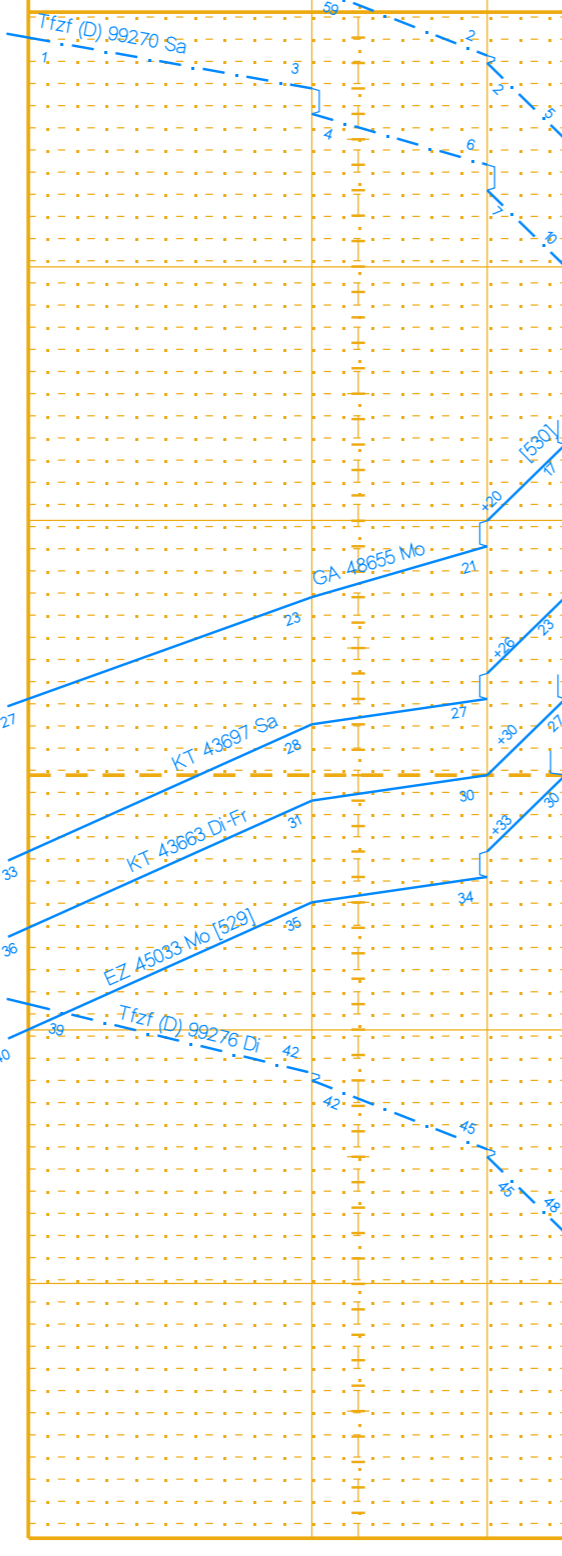
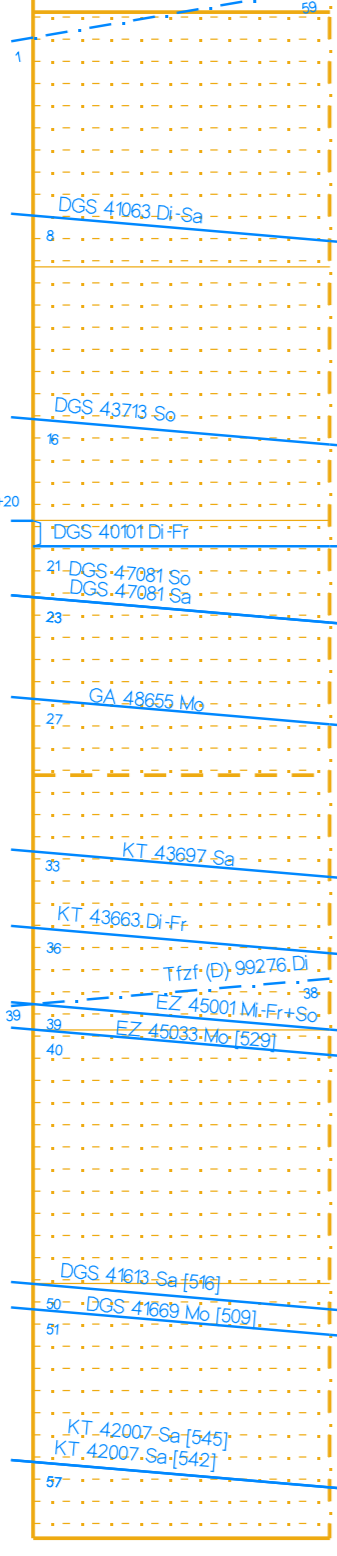
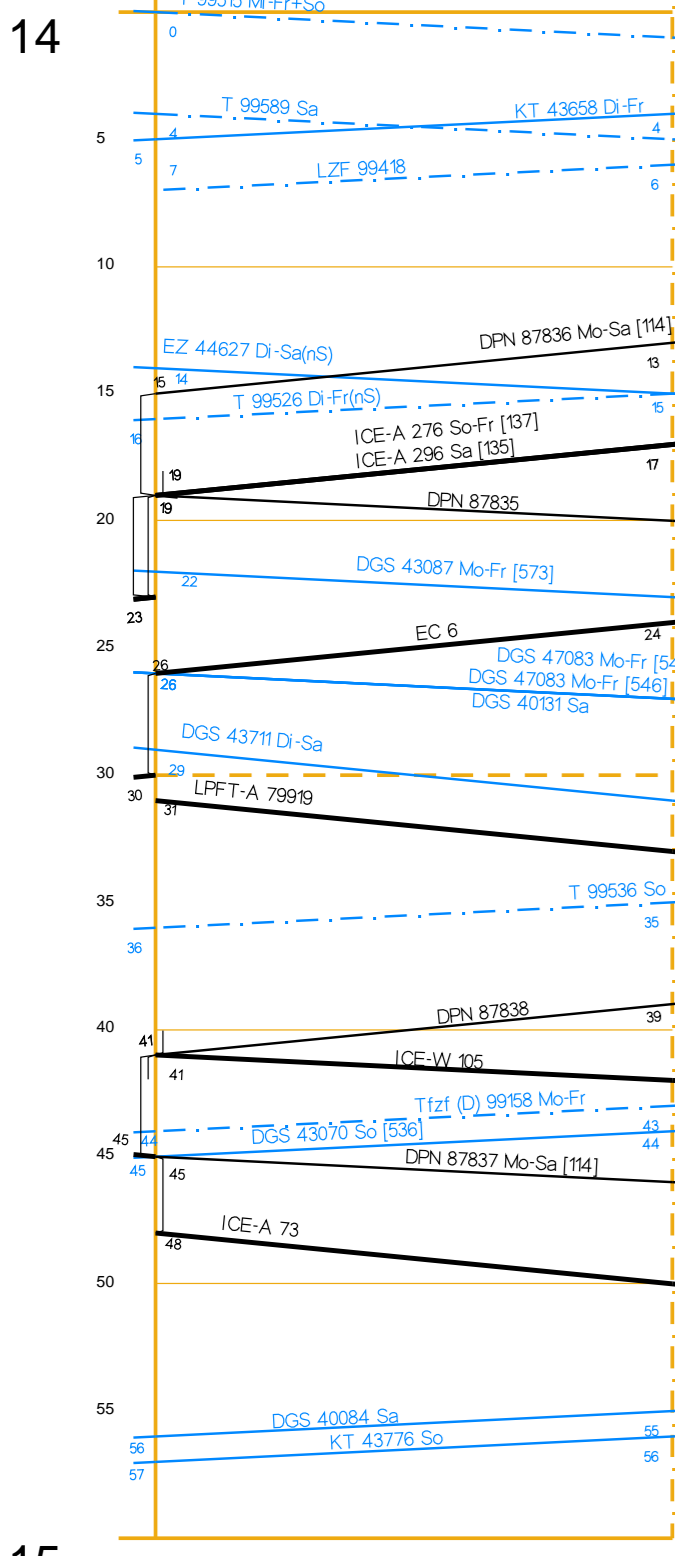
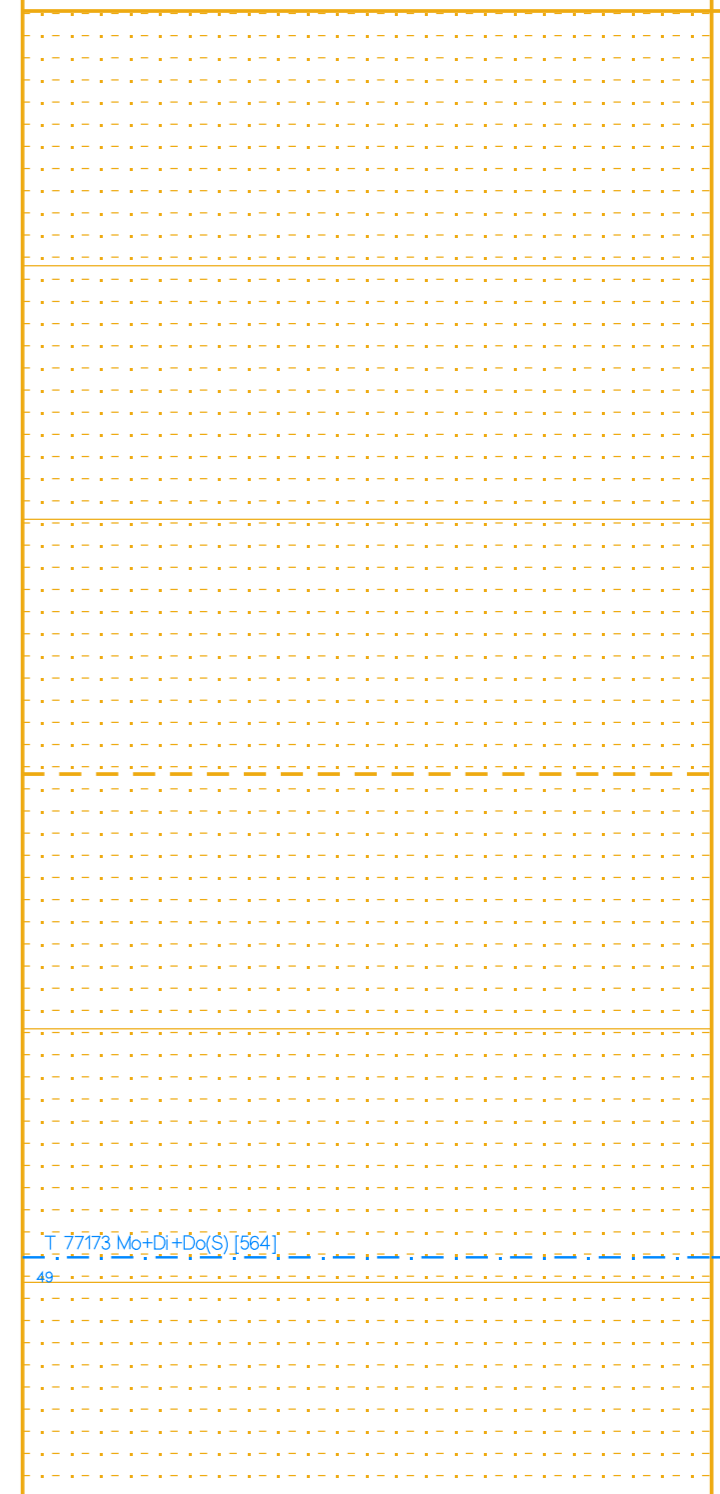
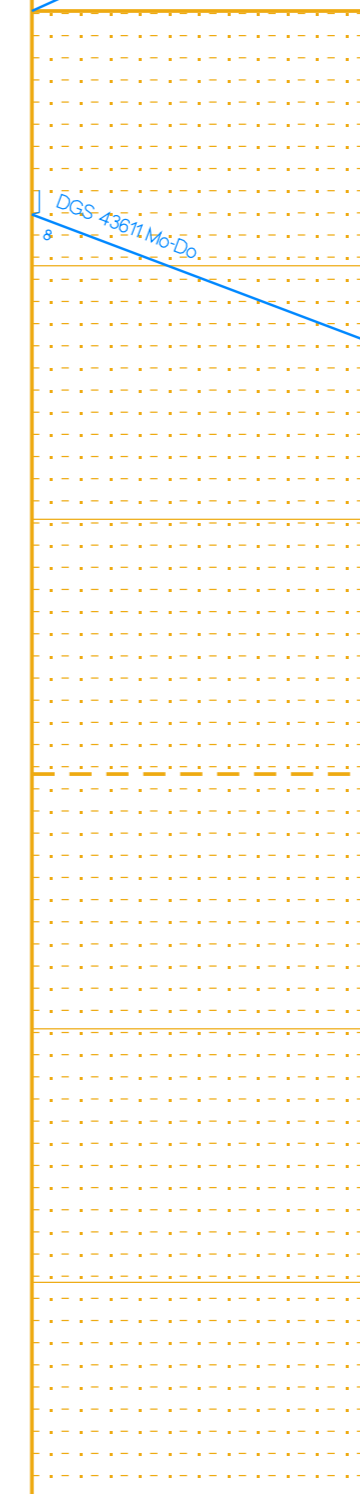
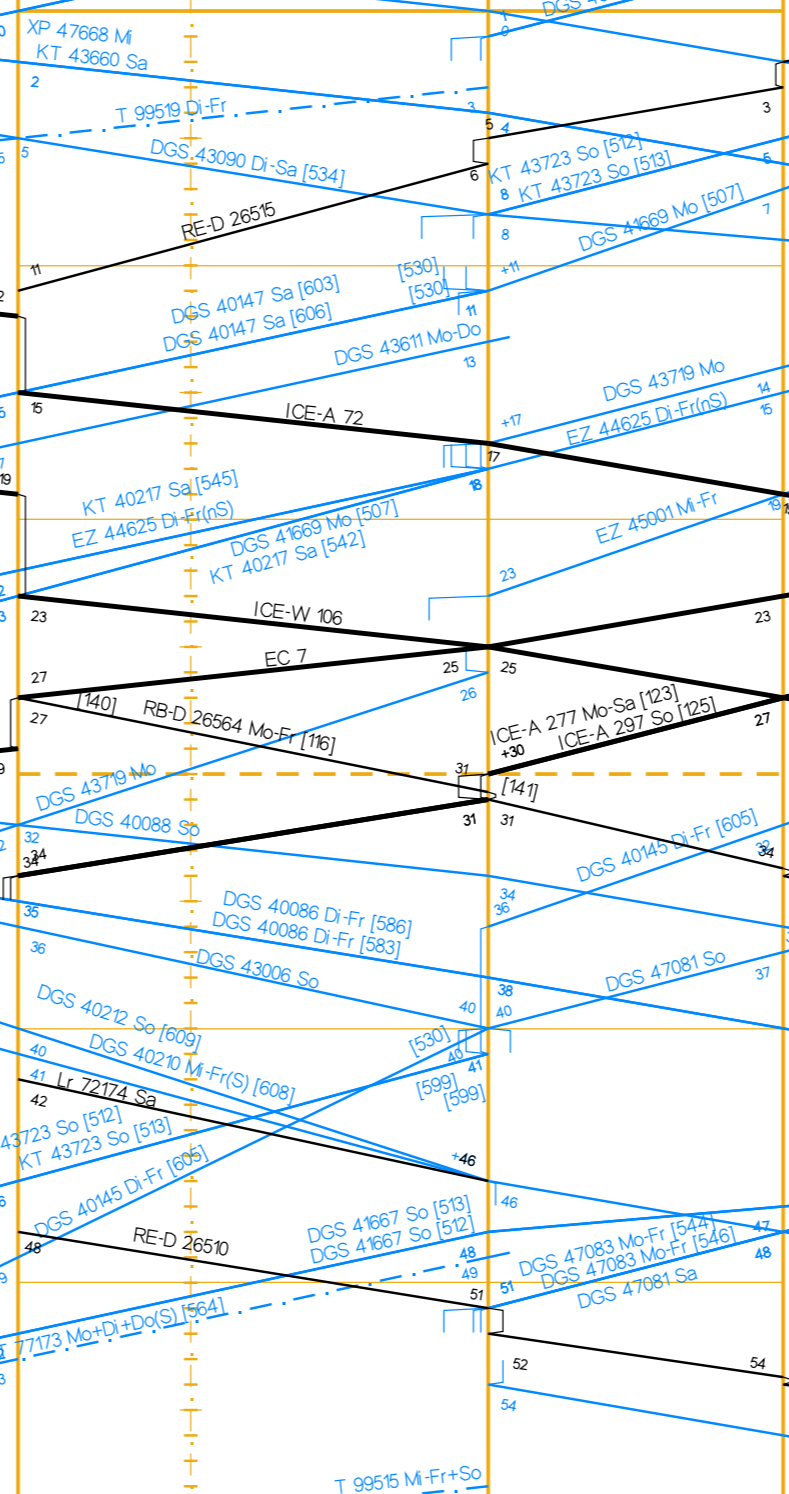
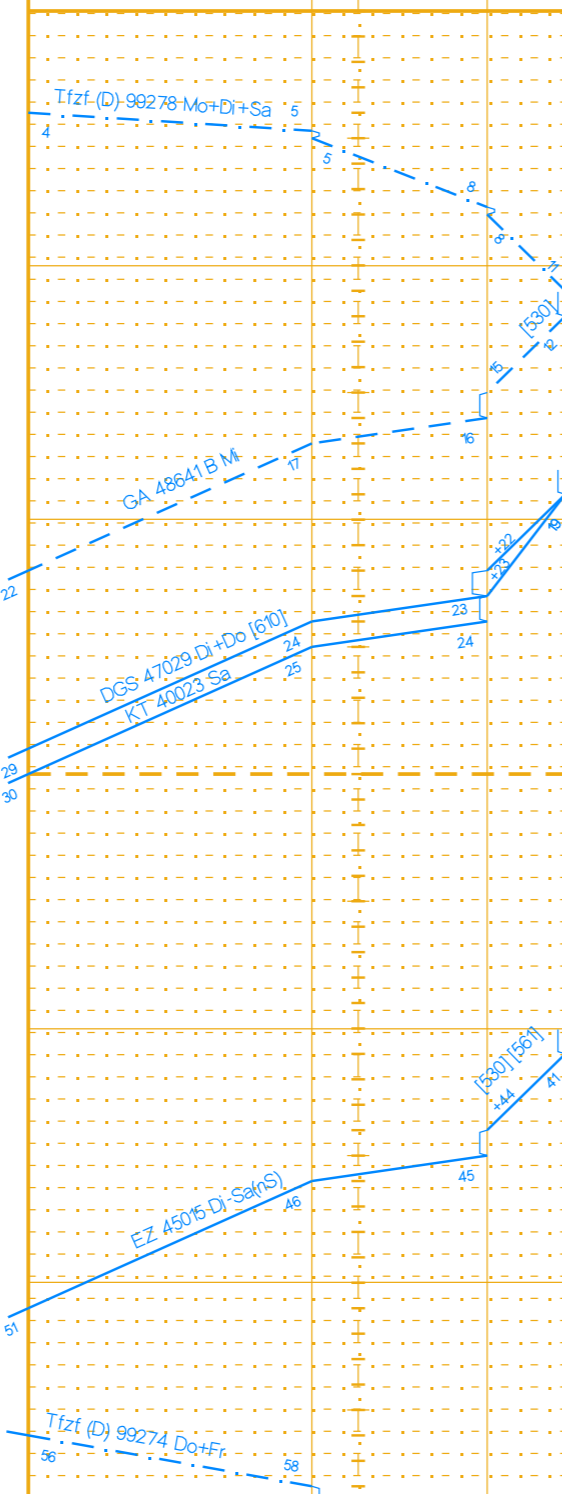
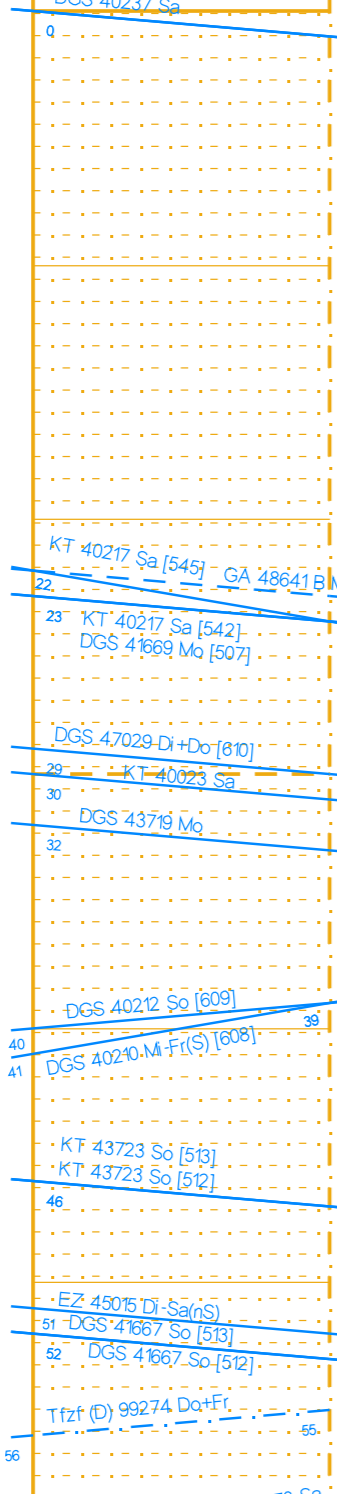
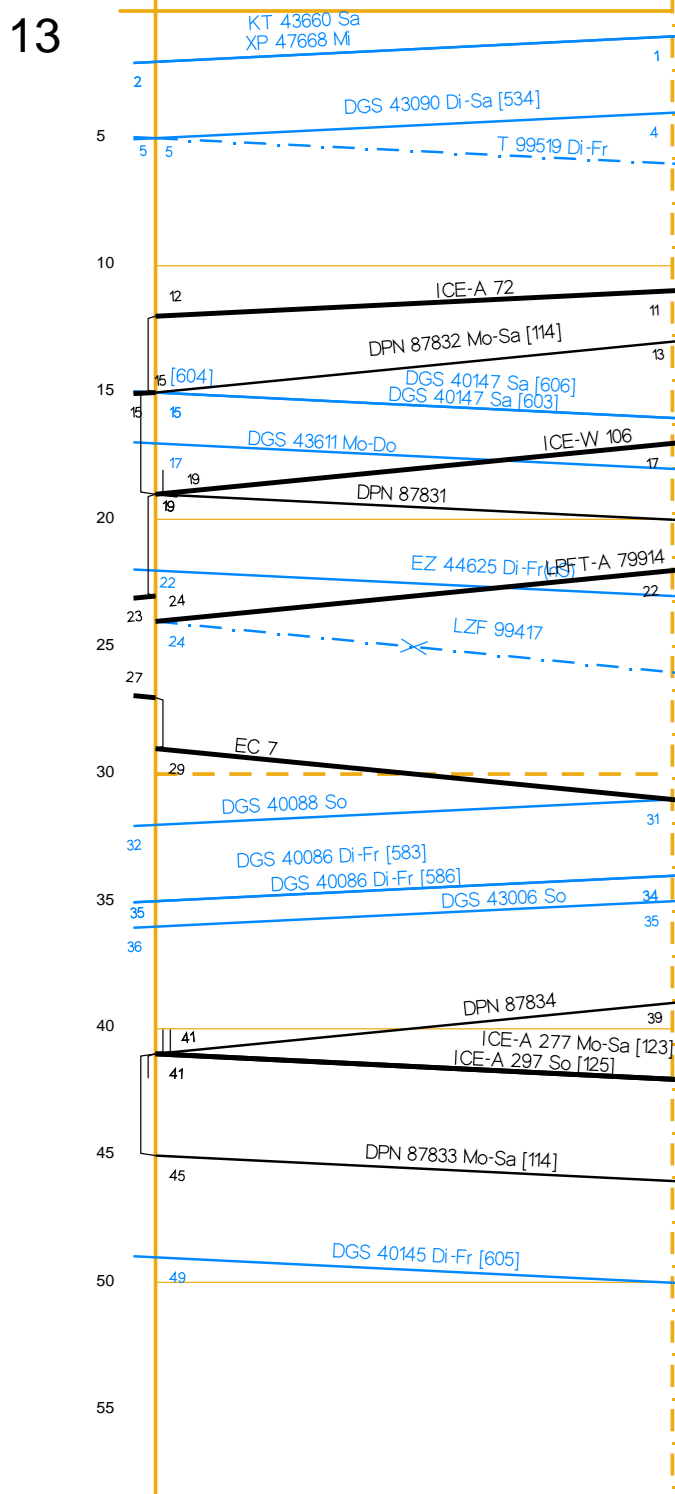
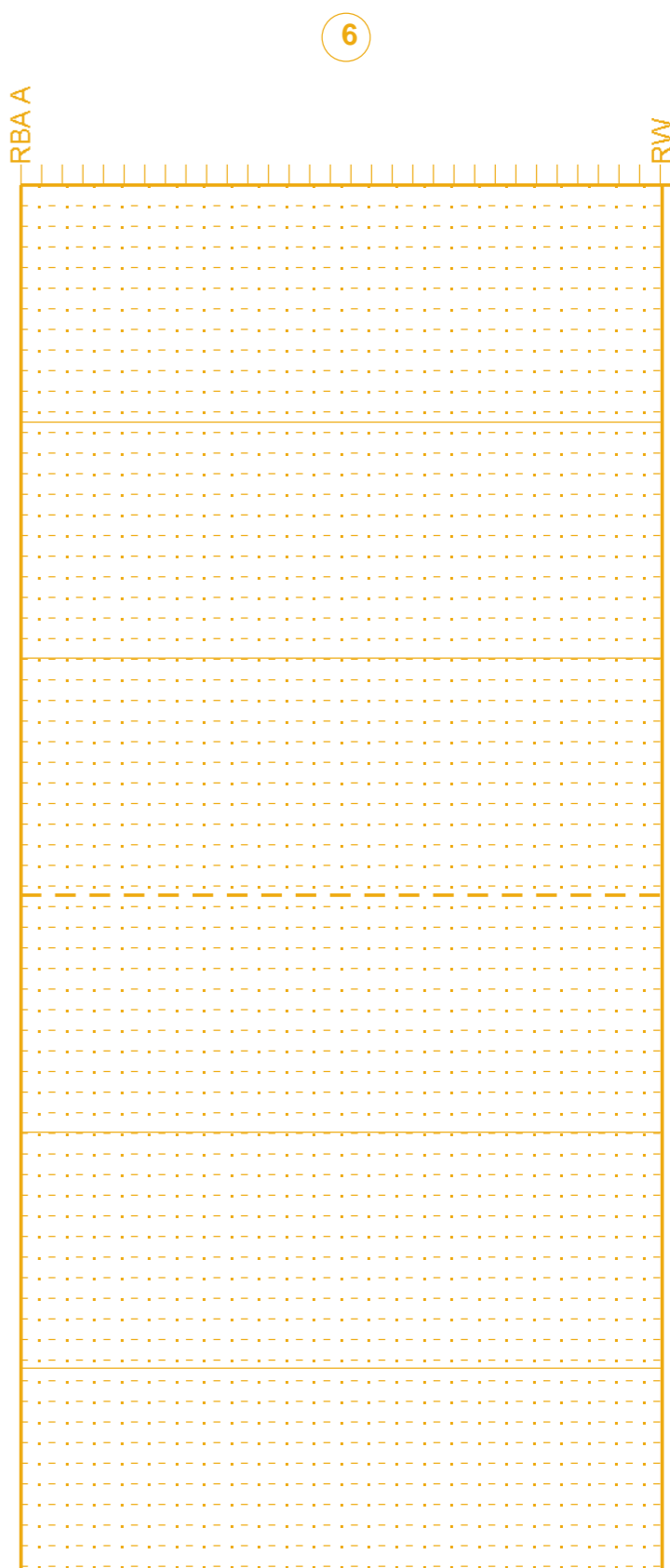
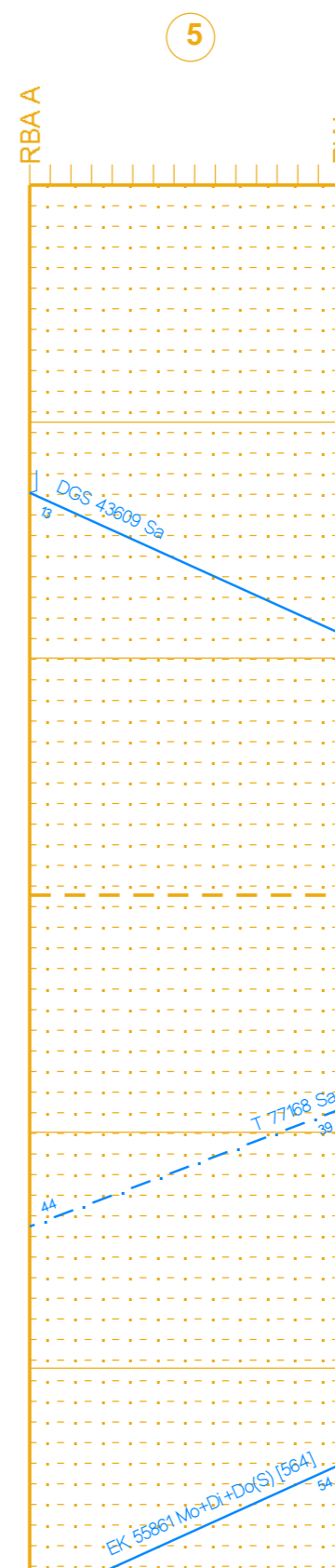
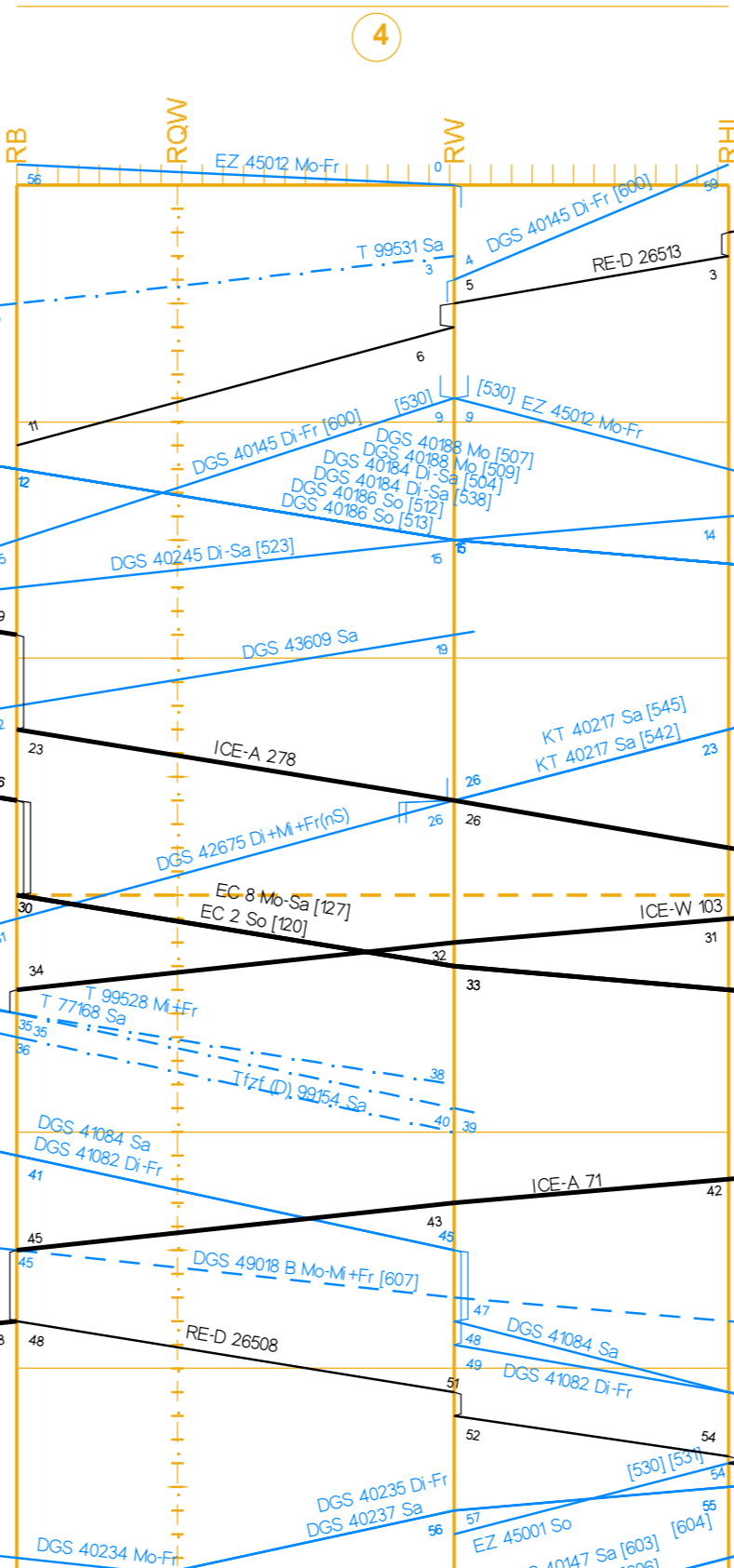
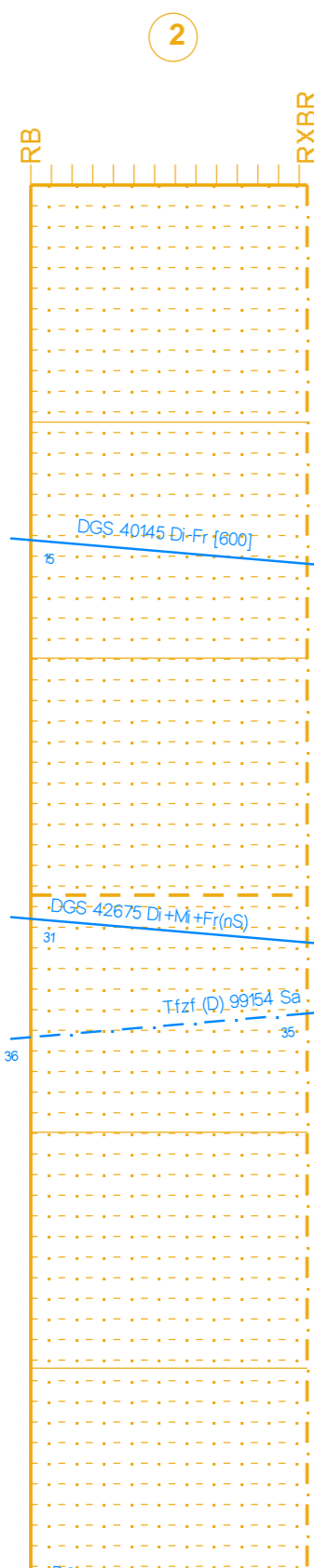
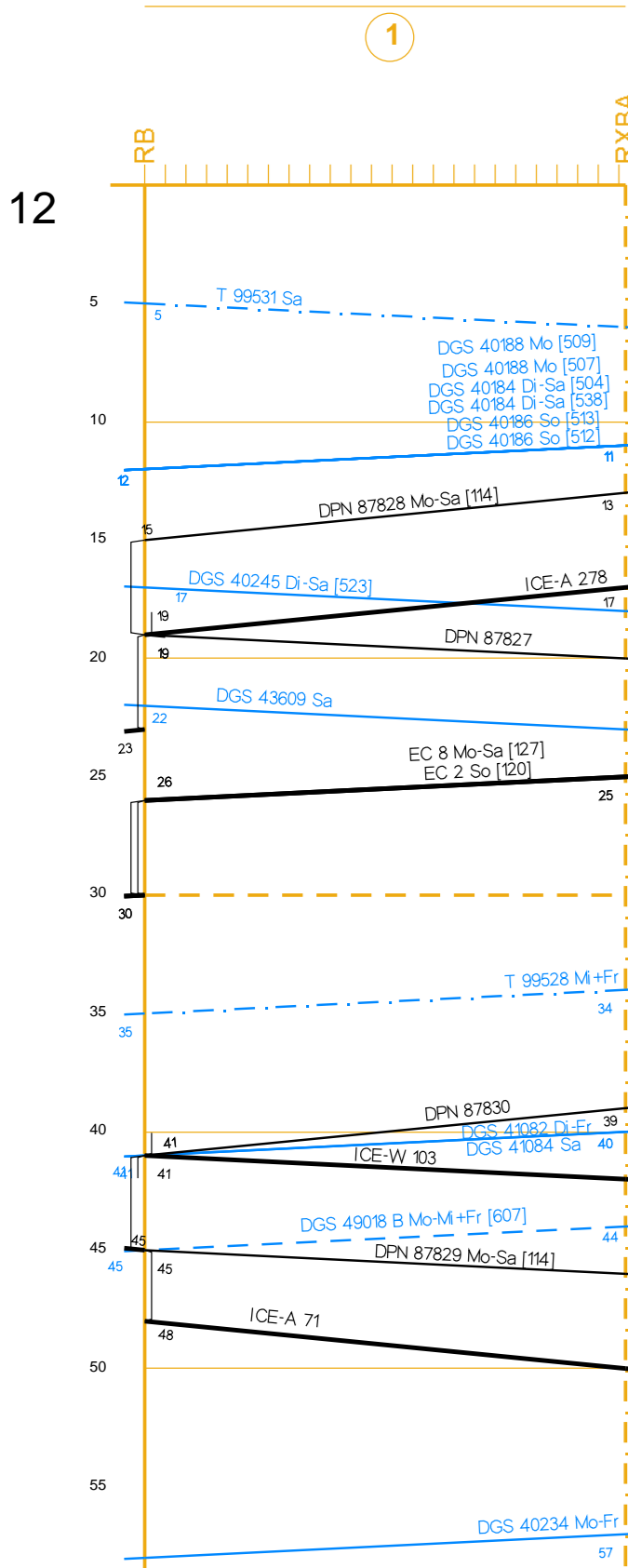

[112] nicht 1.4.13, 20.5.13  
[114] nicht 29.3.13, 1.4.13, 15.13,  
9.5.13, 20.5.13  
[116] nicht 29.3.13, 1.4.13, 15.13,  
9.5.13, 20.5.13, 30.5.13  
[120] nicht 31.3.13, 19.5.13  
auch: 1.4.13, 20.5.13  
[123] nicht 30.3.13, 1.4.13, 20.5.13  
[129] auch: 30.3.13, 1.4.13, 20.5.13

[143] nicht 29.3.13, 1.4.13, 30.4.13,  
1.5.13, 8.5.13, 9.5.13,  
20.5.13, 29.5.13, 30.5.13  
[144] nicht 29.3.13, 1.4.13, 15.13,  
13.7  
[145] nicht 1.4.13, 20.5.13  
«darf bereits um 13:26 Uhr abfahren»  
[146] nicht 1.4.13, 20.5.13  
«darf bereits um 13:30 Uhr abfahren»

[504] 18.3.13 - 20.5.13 Di-Sa  
[507] 21.5.13 - 8.6.13 Mo  
[508] 18.3.13 - 20.5.13 Mo  
[510] 18.3.13 - 20.5.13 So  
[511] 21.5.13 - 8.6.13 So  
[518] nicht 30.3.13  
[523] nicht 30.3.13, 2.4.13, 21.5.13  
[529] nicht 1.4.13, 20.5.13  
[533] Zugantriebswechsel  
[531] Systemwechsel

[534] nicht 29.3.13, 30.3.13, 2.4.13  
[578] nicht 29.3.13, 1.4.13, 2.4.13,  
20.5.13  
[583] 21.5.13 - 8.6.13 Di-Fr  
[586] 18.3.13 - 20.5.13 Di-Fr  
[589] 18.3.13 - 20.5.13 Di-Fr  
[590] Vorspann zu  
[591] nicht 31.3.13  
[600] 1.4.13 - 8.6.13 Di-Fr  
[603] 18.3.13 - 31.3.13 Sa  
[604] gegenseitiger Anschluss mit Zug  
«0145»  
[611] 18.3.13 - 31.3.13 Di-Fr

[600] 1.4.13 - 8.6.13 Sa  
[607] nicht 29.3.13, 1.4.13, 20.5.13  
[608] 18.3.13 - 31.3.13 Mo-Fr  
[609] 18.3.13 - 31.3.13 So  
[610] nicht 31.3.13  
[611] nicht 18.3.13, 2.4.13, 4.4.13,  
5.13, 30.5.13  
[612] auch: 3.4.13, 5.4.13, 3.5.13  
[613] Übernahme von BLS Cargo

[614] nicht 29.3.13, 1.4.13, 15.13,  
9.5.13, 20.5.13  
[616] nicht 29.3.13, 1.4.13, 15.13,  
9.5.13, 20.5.13, 30.5.13  
[620] nicht 31.3.13, 19.5.13  
auch: 1.4.13, 20.5.13  
[623] nicht 30.3.13, 1.4.13, 20.5.13  
[629] auch: 30.3.13, 1.4.13, 20.5.13  
[633] Zugantriebswechsel  
[631] Systemwechsel



Table with 2 columns: Station names (Basel Bad Bf, Basel SBB Pb) and values (GWB, PZB, Hauptbahn, Nebenbahn, 70<1100>, 4404, 1,8, 3,5).

BAV 520

Table with 2 columns: Station names (Basel Bad Bf, Basel SBB Rb) and values (PZB, Hauptbahn, Nebenbahn, 60, 4405, 0,9, 0,0).

BAV 508 / 1

Table with 2 columns: Station names (Basel Bad Bf, Basel Bad Rbf (GR A)) and values (PZB, Hauptbahn, Nebenbahn, 60, 4405, 1,9, 2,6, 3,1, 0,8, 0,4, 2,2).

BAV 508 / 2

Table with 2 columns: Station names (Basel Bad Rbf, Weil (Rh) - Hattlingen) and values (GWB, LZB und PZB, Hauptbahn, Nebenbahn, 130<1160>, 4000, 160, 2,0, 2,6, 1,1, 2,6, 3,3, 2,0, 2,6).

BAV 521 / 1

Table with 2 columns: Station names (Basel Bad Rbf, Weil (Schlaufe)) and values (PZB, Nebenbahn, Hauptbahn, Nebenbahn, 60, 4411, 2,7, 0,8).

3,5

Table with 2 columns: Station names (Basel Bad Rbf, Weil (Sig N10)) and values (PZB, Nebenbahn, Hauptbahn, Nebenbahn, 60, 4415, 1,3, 0,0).

0,0

Basel Bad Bf

Basel Bad Bf

BR Einf/Multizenz

Basel Bad Bf

BR Rbf -Gr-L- Basel Rbf LGr

BR Rbf -Gr-C-

BR Rbf -Gr-A-

Basel Bad Bf

Weil (Rhein) LGr

Weil am Rhein

BR Rbf -Gr-A-

Weil am Rhein

BR Rbf -Gr-A-

Weil am Rhein

15

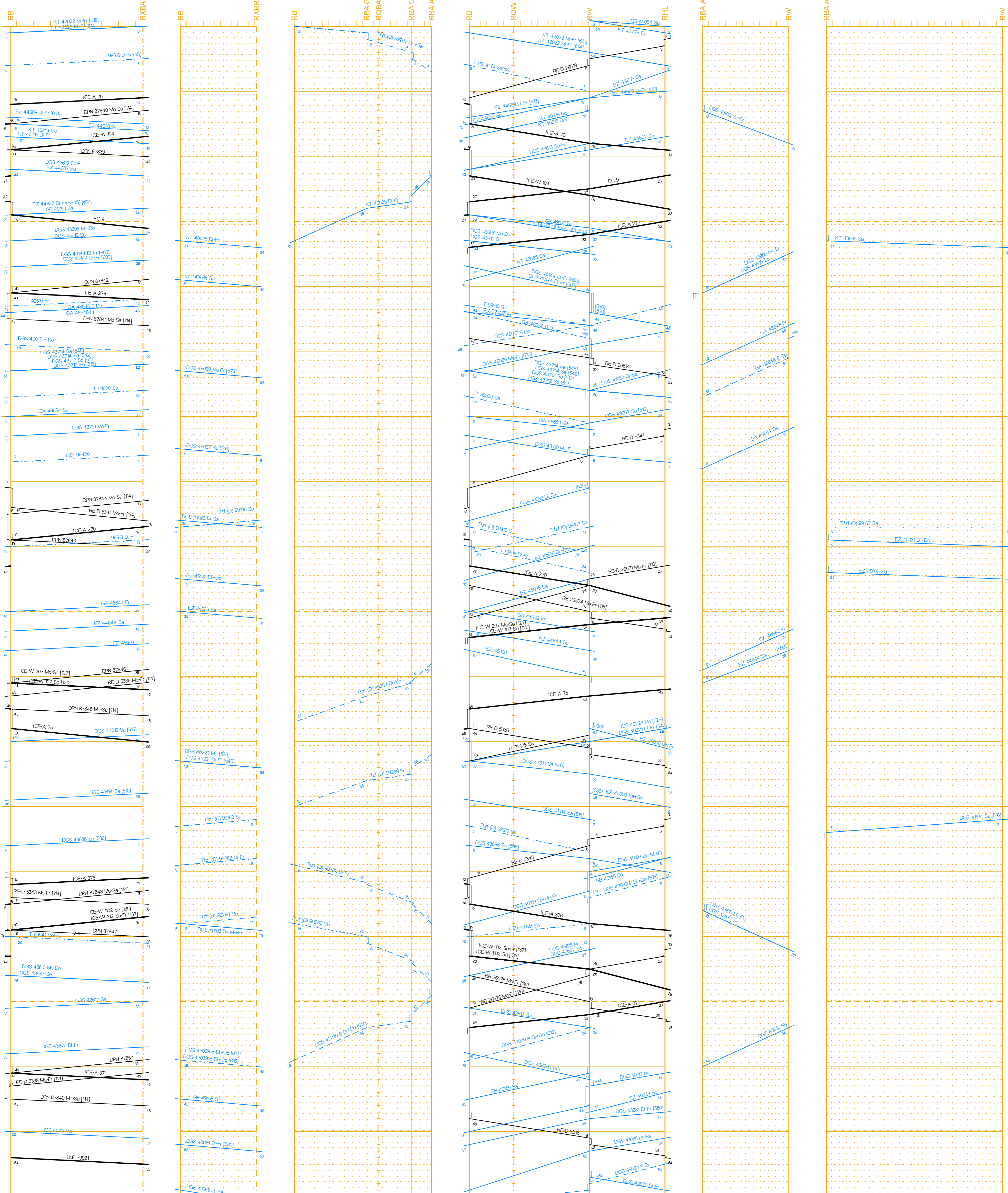

15

16

17

18

[114] nicht 29.3.13, 1.4.13, 1.5.13, 9.5.13, 20.5.13 [116] nicht 29.3.13, 1.4.13, 1.5.13, 9.5.13, 20.5.13, 30.5.13 [120] nicht 31.3.13, 19.5.13 auch: 1.4.13, 20.5.13 [127] nicht 1.4.13, 20.5.13 auch: 31.3.13, 19.5.13 auch: 29.3.13, 31.3.13, 19.5.13, 19.5.13 [137] nicht 29.3.13, 31.3.13, 19.5.13

[512] 18.3.13 - 20.5.13 So [513] 21.5.13 - 8.6.13 So [516] nicht 30.3.13 [526] nicht 1.4.13, 20.5.13 [530] Zugersonnwechsell [536] nicht 31.3.13, 19.5.13 [540] nicht 29.3.13, 19.5.13 [542] 21.5.13 - 8.6.13 Sa [545] 18.3.13 - 20.5.13 Sa [559] Grenzverkehrsbehandlung

[614] 21.5.13 - 8.6.13 Mi-Fr [615] 18.3.13 - 20.5.13 Mi-Fr [616] 21.5.13 - 8.6.13 Di+Do [617] 18.3.13 - 20.5.13 Di+Do [618] nicht 29.3.13, 1.4.13, 2.4.13, 20.5.13 [600] nicht 29.3.13, 2.4.13, 8.6.13 [601] 1.4.13 - 8.6.13 Di-Fr [605] 18.3.13 - 31.3.13 Di-Fr [602] 8.4.13 - 8.6.13 Di-Fr+Sa+So [613] nicht 2.4.13, 2.5.13, 10.5.13, 21.5.13 [619] 21.5.13 - 8.6.13 Mi-Fr [619] 18.3.13 - 20.5.13 Mi-Fr

RBA G ROBA RBA C RBA A

RB ROW RW RHL

RBA A RW

RBA A RW



Fahrpläne Basel Nord Sued ab 18.03.2013

Stunden: 18 - 21

DB Netz

Niederlassung Südwest

Jahresfahrplan 2013 vom: 09. Dezember 2012 bis: 14. Dezember 2013  
Gültig vom: 18. März 2013 bis: 08. Juni 2013 / täglich

Fahrpläne Basel Nord Sued ab 18.03.2013

Stunden: 18 - 21

Table with 2 columns: Station (Basel Bad Bf, Basel SBB Pb) and various service codes (GW6, P2B, Hauptbahn, Nebenbahn, etc.)

Table with 2 columns: Station (Basel Bad Bf, Basel SBB Rb) and various service codes (P2B, Hauptbahn, Nebenbahn, etc.)

Table with 2 columns: Station (Basel Bad Bf, Basel Bad Rbf (GR A)) and various service codes (P2B, Hauptbahn, Nebenbahn, etc.)

Table with 2 columns: Station (Basel Bad Rbf, Weil (Rh) - Haltingen) and various service codes (GW6, L2B und P2B, Hauptbahn, Nebenbahn, etc.)

Table with 2 columns: Station (Basel Bad Rbf, Weil (Schlaufe)) and various service codes (P2B, Nebenbahn, Hauptbahn, Nebenbahn, etc.)

Table with 2 columns: Station (Basel Bad Rbf, Weil (Sig N10)) and various service codes (P2B, Hauptbahn, Nebenbahn, etc.)

BAV 520

BAV 508 / 1

BAV 508 / 2

BAV 521 / 1

Basel Bad Bf  
BR Einf SBB Pb

Basel Bad Bf  
BR Einf Mültenz

Basel Bad Bf  
BR Rbf -Gr-L  
Basel Rbf LGr  
BR Rbf -Gr-C  
BR Rbf -Gr-A

Basel Bad Bf  
Weil (Rhein) LGr  
Weil am Rhein  
Weil am Rhein

Basel Bad Rbf -Gr-A  
Weil am Rhein

Basel Bad Rbf -Gr-A  
Weil am Rhein

1

2

3

4

5

6

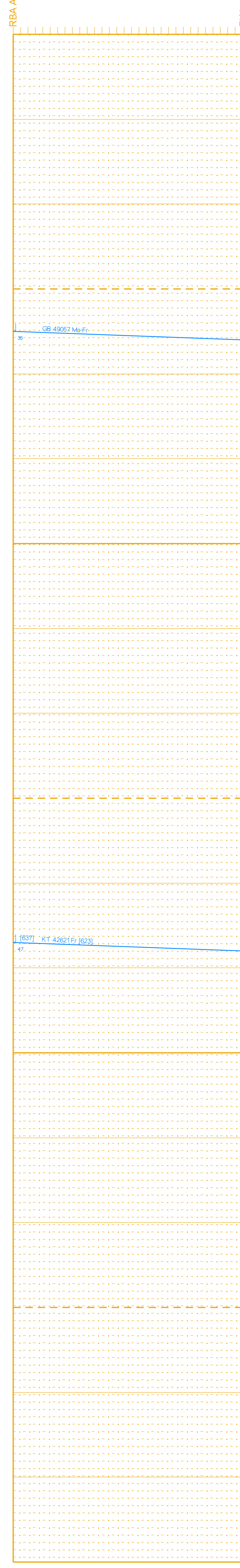
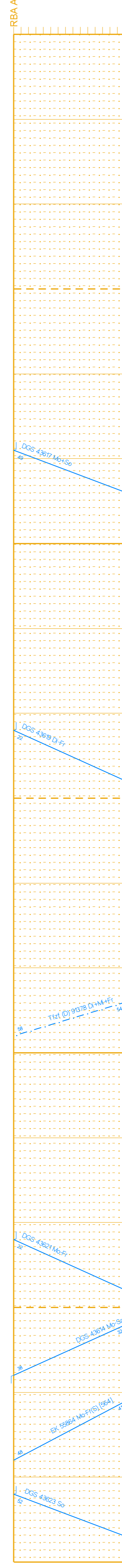
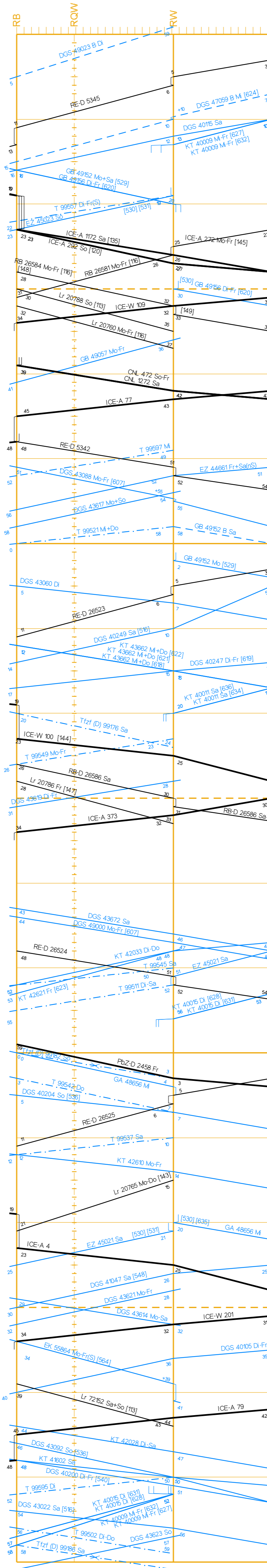
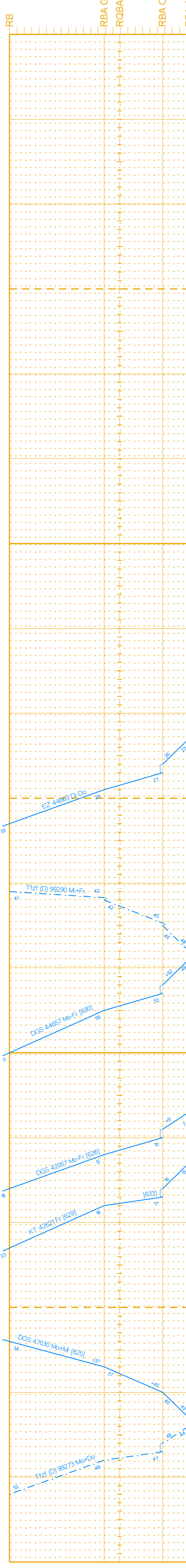
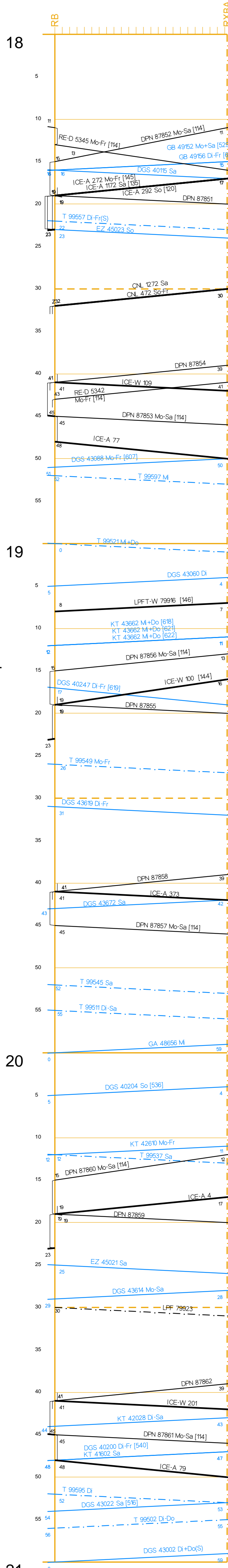

18

19

20

21

18

19

[113] auch: 29.3.13, 1.4.13, 1.5.13, 9.5.13, 20.5.13, 30.5.13  
[114] nicht: 29.3.13, 1.4.13, 1.5.13, 9.5.13, 20.5.13, 30.5.13  
[143] nicht: 28.3.13, 1.4.13, 30.4.13, 1.5.13, 8.5.13, 9.5.13, 20.5.13, 30.5.13  
[144] nicht: 29.3.13, 1.4.13, 1.5.13, 9.5.13, 20.5.13, 30.5.13  
[145] nicht: 29.3.13, 1.4.13, 1.5.13, 9.5.13, 20.5.13, 30.5.13  
[146] nicht: 29.3.13, 1.4.13, 1.5.13, 9.5.13, 20.5.13, 30.5.13  
[147] nicht: 29.3.13, 1.4.13, 1.5.13, 9.5.13, 20.5.13, 30.5.13  
[148] nicht: 29.3.13, 1.4.13, 1.5.13, 9.5.13, 20.5.13, 30.5.13  
[149] nicht: 29.3.13, 1.4.13, 1.5.13, 9.5.13, 20.5.13, 30.5.13  
[150] nicht: 29.3.13, 1.4.13, 1.5.13, 9.5.13, 20.5.13, 30.5.13

[143] nicht: 28.3.13, 1.4.13, 30.4.13, 1.5.13, 8.5.13, 9.5.13, 20.5.13, 30.5.13  
[144] nicht: 29.3.13, 1.4.13, 1.5.13, 9.5.13, 20.5.13, 30.5.13  
[145] nicht: 29.3.13, 1.4.13, 1.5.13, 9.5.13, 20.5.13, 30.5.13  
[146] nicht: 29.3.13, 1.4.13, 1.5.13, 9.5.13, 20.5.13, 30.5.13  
[147] nicht: 29.3.13, 1.4.13, 1.5.13, 9.5.13, 20.5.13, 30.5.13  
[148] nicht: 29.3.13, 1.4.13, 1.5.13, 9.5.13, 20.5.13, 30.5.13  
[149] nicht: 29.3.13, 1.4.13, 1.5.13, 9.5.13, 20.5.13, 30.5.13  
[150] nicht: 29.3.13, 1.4.13, 1.5.13, 9.5.13, 20.5.13, 30.5.13

[151] nicht: 30.3.13  
[152] nicht: 1.4.13, 20.5.13  
[153] Zugpersonalwechsel  
[154] Systemwechsel  
[155] nicht: 31.3.13, 19.5.13  
[156] nicht: 29.3.13  
[157] nicht: 8.4.13 - 8.4.13 Mo  
[158] nicht: 8.4.13 - 8.4.13 Sa  
[159] nicht: 30.5.13  
[160] nicht: 29.3.13, 1.4.13, 20.5.13  
[161] nicht: 1.5.13, 20.5.13  
[162] nicht: 2.4.13, 4.4.13, 2.5.13, 17.5.13  
[163] nicht: 2.4.13

[164] nicht: 2.4.13 - 8.6.13 Sa  
[165] keine Drehfahrt  
[166] 18.3.13 - 1.4.13 Mo  
[167] 18.3.13 - 1.4.13 Di  
[168] 18.3.13 - 1.4.13 Mi  
[169] 18.3.13 - 1.4.13 Do  
[170] 18.3.13 - 1.4.13 Fr  
[171] 18.3.13 - 1.4.13 Sa  
[172] 18.3.13 - 1.4.13 So  
[173] 18.3.13 - 1.4.13 Mo  
[174] 18.3.13 - 1.4.13 Di  
[175] 18.3.13 - 1.4.13 Mi  
[176] 18.3.13 - 1.4.13 Do  
[177] 18.3.13 - 1.4.13 Fr  
[178] 18.3.13 - 1.4.13 Sa  
[179] 18.3.13 - 1.4.13 So  
[180] 18.3.13 - 1.4.13 Mo  
[181] 18.3.13 - 1.4.13 Di  
[182] 18.3.13 - 1.4.13 Mi  
[183] 18.3.13 - 1.4.13 Do  
[184] 18.3.13 - 1.4.13 Fr  
[185] 18.3.13 - 1.4.13 Sa  
[186] 18.3.13 - 1.4.13 So  
[187] 18.3.13 - 1.4.13 Mo  
[188] 18.3.13 - 1.4.13 Di  
[189] 18.3.13 - 1.4.13 Mi  
[190] 18.3.13 - 1.4.13 Do  
[191] 18.3.13 - 1.4.13 Fr  
[192] 18.3.13 - 1.4.13 Sa  
[193] 18.3.13 - 1.4.13 So  
[194] 18.3.13 - 1.4.13 Mo  
[195] 18.3.13 - 1.4.13 Di  
[196] 18.3.13 - 1.4.13 Mi  
[197] 18.3.13 - 1.4.13 Do  
[198] 18.3.13 - 1.4.13 Fr  
[199] 18.3.13 - 1.4.13 Sa  
[200] 18.3.13 - 1.4.13 So

[164] nicht: 2.4.13 - 8.6.13 Sa  
[165] keine Drehfahrt  
[166] 18.3.13 - 1.4.13 Mo  
[167] 18.3.13 - 1.4.13 Di  
[168] 18.3.13 - 1.4.13 Mi  
[169] 18.3.13 - 1.4.13 Do  
[170] 18.3.13 - 1.4.13 Fr  
[171] 18.3.13 - 1.4.13 Sa  
[172] 18.3.13 - 1.4.13 So  
[173] 18.3.13 - 1.4.13 Mo  
[174] 18.3.13 - 1.4.13 Di  
[175] 18.3.13 - 1.4.13 Mi  
[176] 18.3.13 - 1.4.13 Do  
[177] 18.3.13 - 1.4.13 Fr  
[178] 18.3.13 - 1.4.13 Sa  
[179] 18.3.13 - 1.4.13 So  
[180] 18.3.13 - 1.4.13 Mo  
[181] 18.3.13 - 1.4.13 Di  
[182] 18.3.13 - 1.4.13 Mi  
[183] 18.3.13 - 1.4.13 Do  
[184] 18.3.13 - 1.4.13 Fr  
[185] 18.3.13 - 1.4.13 Sa  
[186] 18.3.13 - 1.4.13 So  
[187] 18.3.13 - 1.4.13 Mo  
[188] 18.3.13 - 1.4.13 Di  
[189] 18.3.13 - 1.4.13 Mi  
[190] 18.3.13 - 1.4.13 Do  
[191] 18.3.13 - 1.4.13 Fr  
[192] 18.3.13 - 1.4.13 Sa  
[193] 18.3.13 - 1.4.13 So  
[194] 18.3.13 - 1.4.13 Mo  
[195] 18.3.13 - 1.4.13 Di  
[196] 18.3.13 - 1.4.13 Mi  
[197] 18.3.13 - 1.4.13 Do  
[198] 18.3.13 - 1.4.13 Fr  
[199] 18.3.13 - 1.4.13 Sa  
[200] 18.3.13 - 1.4.13 So

[164] nicht: 2.4.13 - 8.6.13 Sa  
[165] keine Drehfahrt  
[166] 18.3.13 - 1.4.13 Mo  
[167] 18.3.13 - 1.4.13 Di  
[168] 18.3.13 - 1.4.13 Mi  
[169] 18.3.13 - 1.4.13 Do  
[170] 18.3.13 - 1.4.13 Fr  
[171] 18.3.13 - 1.4.13 Sa  
[172] 18.3.13 - 1.4.13 So  
[173] 18.3.13 - 1.4.13 Mo  
[174] 18.3.13 - 1.4.13 Di  
[175] 18.3.13 - 1.4.13 Mi  
[176] 18.3.13 - 1.4.13 Do  
[177] 18.3.13 - 1.4.13 Fr  
[178] 18.3.13 - 1.4.13 Sa  
[179] 18.3.13 - 1.4.13 So  
[180] 18.3.13 - 1.4.13 Mo  
[181] 18.3.13 - 1.4.13 Di  
[182] 18.3.13 - 1.4.13 Mi  
[183] 18.3.13 - 1.4.13 Do  
[184] 18.3.13 - 1.4.13 Fr  
[185] 18.3.13 - 1.4.13 Sa  
[186] 18.3.13 - 1.4.13 So  
[187] 18.3.13 - 1.4.13 Mo  
[188] 18.3.13 - 1.4.13 Di  
[189] 18.3.13 - 1.4.13 Mi  
[190] 18.3.13 - 1.4.13 Do  
[191] 18.3.13 - 1.4.13 Fr  
[192] 18.3.13 - 1.4.13 Sa  
[193] 18.3.13 - 1.4.13 So  
[194] 18.3.13 - 1.4.13 Mo  
[195] 18.3.13 - 1.4.13 Di  
[196] 18.3.13 - 1.4.13 Mi  
[197] 18.3.13 - 1.4.13 Do  
[198] 18.3.13 - 1.4.13 Fr  
[199] 18.3.13 - 1.4.13 Sa  
[200] 18.3.13 - 1.4.13 So

21



Fahrpläne Basel Nord Sued ab 18.03.2013

Stunden: 21 - 24

DB Netz

Niederlassung Südwest

Jahresfahrplan 2013 vom: 09. Dezember 2012 bis: 14. Dezember 2013  
Gültig vom: 18. März 2013 bis: 08. Juni 2013 / täglich

Fahrpläne Basel Nord Sued ab 18.03.2013

Stunden: 21 - 24

Table with 2 columns: Station, Distance. Includes Basel Bad Bf, Basel SBB Pb, GwB, PZB, Hauptbahn, 70 <1100 >, 4404, 1.8, 3.5.

BAV 520

Table with 2 columns: Station, Distance. Includes Basel Bad Bf, Basel SBB Rb, PZB, Hauptbahn, 60, 4405, 0.9, 0.0.

BAV 508 / 1

Table with 3 columns: Station, Distance. Includes Basel Bad Bf, Basel SBB Rb(GR A), PZB, Hauptbahn, Nebenbahn, 60, 4405, 1.9, 2.0, 0.3, 0.8, 0.4, 2.1, 0.9, 2.0, 3.1, 0.8, 2.0, 0.4, 2.2.

BAV 508 / 2

Table with 3 columns: Station, Distance. Includes Basel Bad Rbf, Weil (Rh) - Haltingen, GwB, LZB und PZB, Hauptbahn, 130 <1160 >, 4000, 160, 270.7, 2.0, 2.0, 1.1, 4.000, 2.0, 3.3, 2.0, 2.0, 2.7, 0.8, 2.9, 1.3.

BAV 521 / 1

Table with 2 columns: Station, Distance. Includes Basel Bad Rbf, Weil (Schlaufe), PZB, Nebenbahn, Hauptbahn, 60, 4411, 2.7, 0.0.

BAV 521 / 1

Table with 2 columns: Station, Distance. Includes Basel Bad Rbf, Weil (Sig N10), PZB, Hauptbahn, Nebenbahn, 60, 4415, 1.3, 0.0.

BAV 521 / 1

Legend for train types: Basel Bad Bf, BR Einf SBB RB, Basel Bad Bf, BR Einf Mültensz, Basel Bad Bf, BR Rbf -Gr-L, Basel Rbf LGr, BR Rbf -Gr-C, BR Rbf -Gr-A, Basel Bad Bf, Weil (Rhein) LGr, Weil am Rhein, Halltingen, Basel Bad Bf, BR Rbf -Gr-A, Weil am Rhein, BR Rbf -Gr-A, Weil am Rhein.

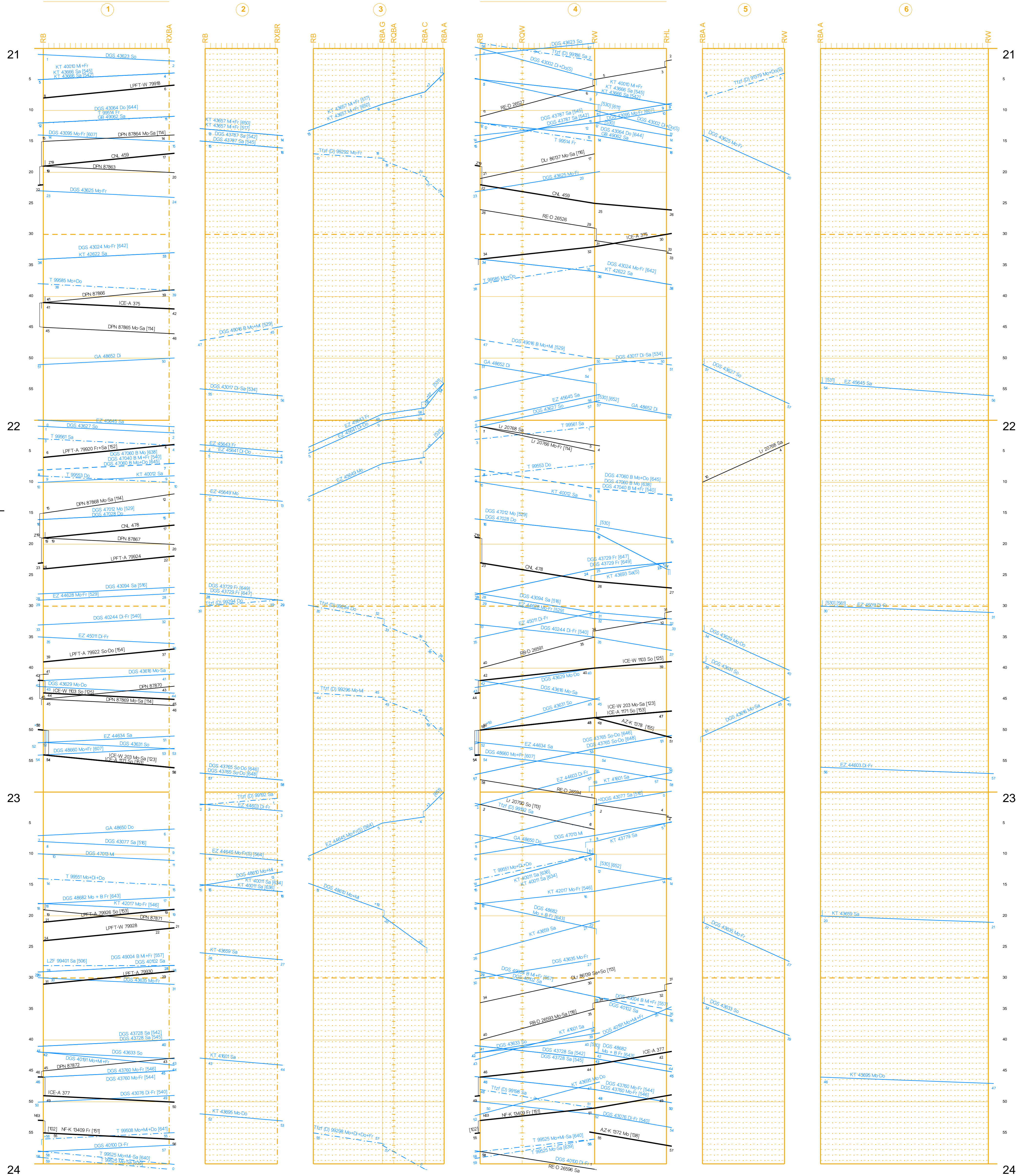

Legend for symbols: [102] Zugpersonalwechsel, [113] auch: 29.3.13, 1.4.13, 1.5.13, [152] 26.4.13 - 8.6.13 Fr, [151] 26.4.13 - 8.6.13 Fr, [152] auch: 28.3.13, 8.5.13, [151] 26.4.13 - 8.6.13 Fr, [152] auch: 1.4.13, 20.5.13, [151] nicht: 29.3.13, 1.4.13, 1.5.13, [154] nicht: 28.3.13, 8.5.13, [150] 18.3.13 - 4.5.13 Mo+Do+Sa, [151] 18.3.13 - 4.5.13 Mo+Do+Sa, [152] nicht: 29.3.13, 1.4.13, 1.5.13, [154] 18.3.13 - 27.5.13 Mo+Do, [151] 18.3.13 - 27.5.13 Mo+Do, [152] nicht: 29.3.13, 30.3.13, 2.4.13, [150] 18.3.13 - 20.5.13, 30.5.13, [151] 18.3.13 - 20.5.13, 30.5.13, [152] auch: 30.3.13, 1.4.13, 20.5.13, [151] 18.3.13 - 8.6.13, [152] auch: 30.3.13, 1.4.13, 20.5.13, [151] 18.3.13 - 20.5.13, 30.5.13, [152] 6.5.13 - 8.6.13 Mo. [306] 1.8.13 - 8.6.13 Sa, [545] 18.3.13 - 20.5.13 Sa, [546] 21.5.13 - 8.6.13 Mo-Fr, [547] 18.3.13 - 20.5.13 Mo-Sa, [548] 1.8.13 - 8.6.13 Mo-Fr, [549] 18.3.13 - 22.5.13, 31.5.13, [550] Systemwechsel, Bremswechsel, [551] Systemwechsel, Bremswechsel, [552] nicht: 29.3.13, 1.4.13, 20.5.13, [553] nicht: 29.3.13, 1.4.13, 20.5.13, [554] nicht: 29.3.13, 1.4.13, 20.5.13, [555] Übernahme von BLS Cargo, [556] 2.4.13 - 8.6.13 Sa, [557] 18.3.13 - 1.4.13 Sa, [558] nicht: 20.5.13, [559] 18.3.13 - 8.6.13 Mo, [560] 18.3.13 - 7.4.13 Mo-Do, [561] 18.3.13 - 7.4.13 Mo-Do, [562] ohne Drehfahrt.