

Basel Bad Bf - Riehen

PZB						
Hauptbahn						
120						
4000						
-18	2.6	0.9	2.2	3.0	1.3	4.3

BAV 525

↓ Basel Bad Bf

Riehen Niederholz Hp

↓ Riehen

Riehen LGr

Basel Bad Bf - Grenzach

GNT und PZB			
Hauptbahn			
130 > 160 <			
4000			
2071	2.5	2.4	2.6

BAV 521 / 2

↓ Basel Bad Bf

Basel Bad Bf LGr

▽ △ Ssk 9093 / Ssk 9092

↓ Grenzach

Basel Bad Bf - Riehen

PZB						
Hauptbahn						
120						
4000						
-18	2.6	0.9	2.2	3.0	1.3	4.3

BAV 525

↓ Basel Bad Bf

Riehen Niederholz Hp

↓ Riehen

Riehen LGr

Basel Bad Bf - Grenzach

GNT und PZB			
Hauptbahn			
130 > 160 <			
4000			
2071	2.5	2.4	2.6

BAV 521 / 2

↓ Basel Bad Bf

Basel Bad Bf LGr

▽ △ Ssk 9093 / Ssk 9092

↓ Grenzach

Basel Bad Bf - Riehen

PZB						
Hauptbahn						
120						
4000						
-18	2.6	0.9	2.2	3.0	1.3	4.3

BAV 525

↓ Basel Bad Bf

Riehen Niederholz Hp

↓ Riehen

Riehen LGr

Basel Bad Bf - Grenzach

GNT und PZB			
Hauptbahn			
130 > 160 <			
4000			
2071	2.5	2.4	2.6

BAV 521 / 2

↓ Basel Bad Bf

Basel Bad Bf LGr

▽ △ Ssk 9093 / Ssk 9092

↓ Grenzach

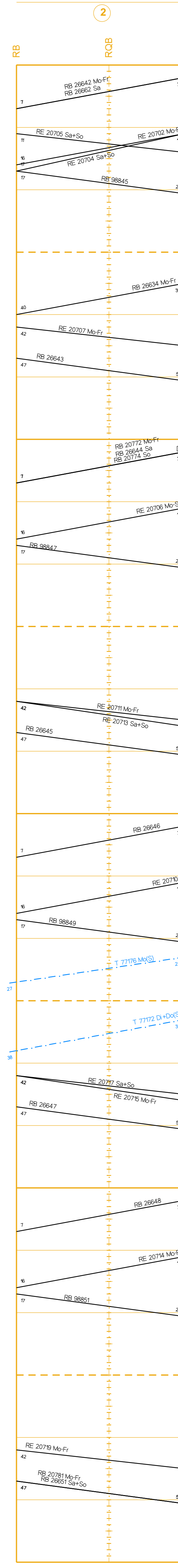
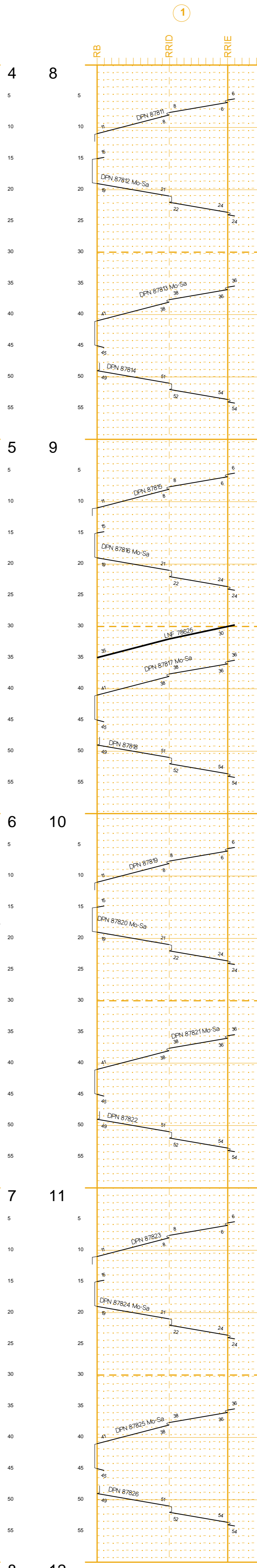
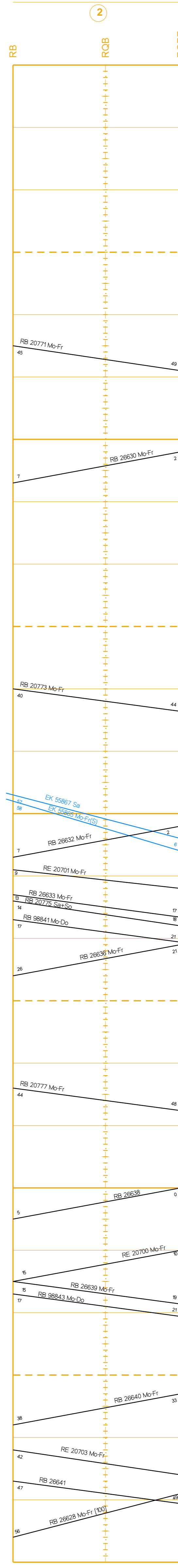
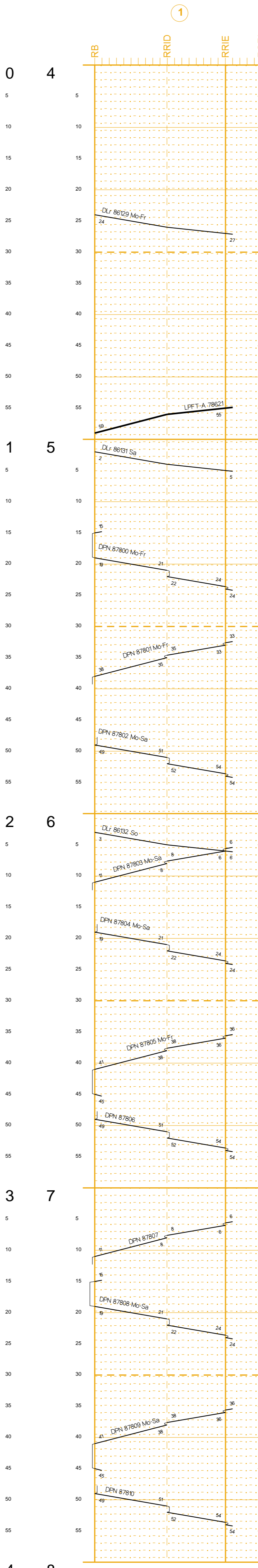
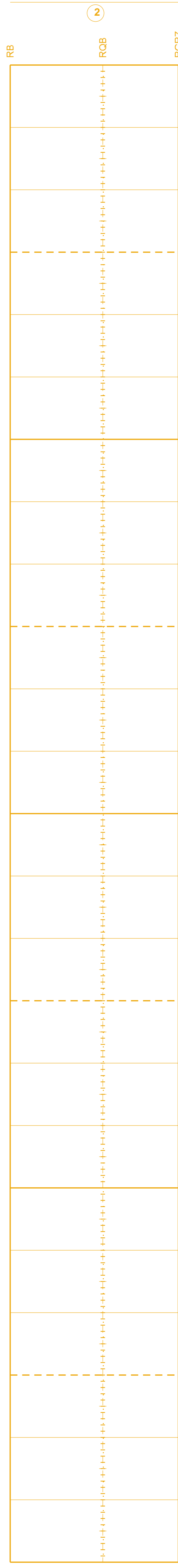
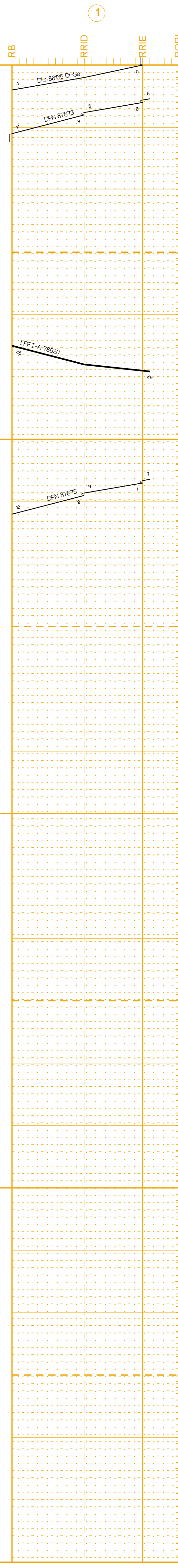

[100] 9.6.13 - 24.7.13 Mo-Fr
8.9.13 - 9.9.13 Mo-Fr

Basel Bad Bf - Riehen				
P2B Hauptbahn 120 4000				
2,6	0,9	2,2	3,0	1,3
-1,8				4,3

Basel Bad Bf - Grenzach				
GNT und P2B Hauptbahn 130 > 160 < 4000				
2,5	2,7			2,4
2,0				2,6

Basel Bad Bf - Riehen				
P2B Hauptbahn 120 4000				
2,6	0,9	2,2	3,0	1,3
-1,8				4,3

Basel Bad Bf - Grenzach				
GNT und P2B Hauptbahn 130 > 160 < 4000				
2,5	2,7			2,4
2,0				2,6

Basel Bad Bf - Riehen				
P2B Hauptbahn 120 4000				
2,6	0,9	2,2	3,0	1,3
-1,8				4,3

Basel Bad Bf - Grenzach				
GNT und P2B Hauptbahn 130 > 160 < 4000				
2,5	2,7			2,4
2,0				2,6

BAV 525

BAV 521 / 2

BAV 525

BAV 521 / 2

BAV 525

BAV 521 / 2

